

# MENCA experiment aboard India's Mars Orbiter Mission

Anil Bhardwaj\*, S. V. Mohankumar, Tirtha Pratim Das, P. Pradeepkumar, P. Sreelatha, B. Sundar, Amarnath Nandi, Dinakar Prasad Vajja, M. B. Dhanya, Neha Naik, G. Supriya, R. Sathesh Thampi, G. Padma Padmanabhan, Vipin K. Yadav and A. V. Aliyas

Vikram Sarabhai Space Centre, Indian Space Research Organisation, Thiruvananthapuram 695 022, India

**The Mars Exospheric Neutral Composition Analyser (MENCA) aboard the Indian Mars Orbiter Mission (MOM) is a quadrupole mass spectrometer-based experiment. Making use of the highly elliptical and low inclination (~150°) orbit of MOM, MENCA will conduct *in situ* measurements of the composition and radial distribution of the Martian neutral exosphere in the 1–300 amu mass range in the equatorial and low latitudes of Mars. The functionality of MENCA has been tested during the Earth-bound and heliocentric phases of MOM before its operation in the Martian orbit. This article describes the scientific objectives, instrument details, design and development, test and evaluation, and calibration of the MENCA instrument.**

**Keywords:** Exosphere, Mars Orbiter, mass spectrometer, thermal escape.

## Introduction

YOUNG Mars is believed to have had a primary atmosphere, lost in the course of time due to the high extreme ultraviolet (EUV) flux of the young Sun and its lower gravity. Subsequently, Mars developed a CO<sub>2</sub>-rich secondary atmosphere due to impact-related volatiles and mantle outgassing, resulting in a surface pressure of few tens to few hundred millibars. Several thermal and non-thermal escape processes, impacts, carbonate precipitation, etc. have resulted in the present-day surface pressure of ~6–7 mbar in Mars<sup>1</sup>. Thermal escape of the atmosphere from Mars plays an important role in the depletion of the Martian atmosphere because of low Martian gravity. A way to understand the thermal escape of the atmosphere is to study the thermal neutrals in the exosphere.

Despite compelling evidences for the presence of a Martian neutral exosphere extending up to several Martian radii<sup>2</sup>, its composition and distribution remain unexplored. So far, the neutral composition of the upper atmosphere of Mars has been studied from 200 km down

to 120 km by the Viking 1 and 2 landers<sup>3,4</sup>. The Martian exosphere starts from an altitude of ~250 km (ref. 5). The only inferences drawn on the Martian exosphere, so far, have been on its total number density based on spacecraft drag measurements and few studies on the extent of hydrogen<sup>6</sup> and oxygen exospheres<sup>7</sup> based on their respective spectral emission signatures. The number density of the Martian exosphere is estimated based on Mars Global Surveyor and Mars Odyssey spacecraft drag measurements depicting the effects of the variation of solar flux as well as annual variations<sup>8</sup>; and the atomic oxygen density estimation with the ALICE instrument aboard the Rosetta mission<sup>9</sup>. The observation of Mars exospheric X-rays using the Reflection Grating Spectrometer/XMM Newton suggests the presence of a neutral exosphere up to ~8 Martian radii<sup>2</sup>. In addition, there have been extensive modelling studies to predict the composition and distribution of the Martian neutral exosphere<sup>5,10–13</sup>. All these studies indicate that there exists a neutral exosphere around Mars that extends several thousands of kilometres.

The Mars Exospheric Neutral Composition Analyser (MENCA) experiment aboard the Indian Mars Orbiter Mission (MOM) will study the distribution of the Martian neutral exosphere approximately along the Martian equatorial plane due to the low inclination (~150°) of the orbit. Taking advantage of the highly elliptical orbit (~400 km periareion and ~70,000 km apoareion) of MOM, the scientific objective of MENCA is to radially profile the composition of the neutral exosphere of Mars starting from the MOM periareion. The MENCA instrument draws its heritage from the Chandra's Altitudinal Composition Explorer (CHACE) instrument aboard the Moon Impact Probe (MIP) of the Chandrayaan-1 mission<sup>14–17</sup>. Figure 1 shows the flight model (FM) of the MENCA instrument.

## Instrument

MENCA is a quadrupole mass spectrometer-based instrument with a cylindrical sensor attached with the electronics (Figure 1a). The sensor of MENCA comprises of an emission circuit featuring an open-source

\*For correspondence. (e-mail: Anil\_Bhardwaj@vssc.gov.in)

hot-cathode electron impact ionizer to ionize the ambient neutrals, a Quadrupole Mass Analyser (QMA) and the detector assembly. The ionizer region houses a pair of filaments with thoria coating on the iridium substrate, operated in hot redundancy. The thermionic electrons generated by the filament are post-accelerated to 70 eV by the electrodes in the ionizer and ionize the ambient neutrals in the ionizer region. A fraction of the ions is collected by the Bayard–Alpert gauge collector, generating a line current, for the total pressure measurement. The gauge can measure the total pressure in the range  $10^{-4}$ – $10^{-10}$  torr.

Rest of the ions are electrostatically dragged through the focusing optics and are made to enter the QMA, which consists of four cylindrical rods for mass dispersion. The superposition of an RF potential over a DC potential applied at the QMA makes the ions of a given charge-to-mass ratio reach the detector in a stable trajectory. Mass-range scanning is accomplished by ramping the amplitude of the RF and DC voltages. The mass range can be scanned at different rates depending on the scientific requirements. Depending on the chosen scan rate, the time taken to scan the complete mass range of 1–300 amu may vary from 19 to 540 sec. The spatial resolution of

observations can be improved by increasing the scan rate and/or by reducing the mass range. However, increasing the scan rate increases the noise level in the instrument.

The detector assembly has a Faraday cup and a Channel Electron Multiplier (CEM). The CEM can be biased at different potentials ranging from 1000 to 2500 V. The gain of the CEM is a function of both the bias voltage and the ion mass; the typical gain for CEM is  $\sim 10^5$ . Partial pressures of  $\sim 10^{-14}$  torr can be measured with the CEM. The MENCA electronics, referred to as MENCA Integrated System Management Unit (MISMU), consists of various electronics cards for power supply, RF generation, signal conditioning, and operation and commanding of MENCA. The power supply, RF, and the signal conditioning cards are collectively referred to as the Probe Control and Communication Unit (PCCU). The various DC and RF voltages for operation of the instrument are generated by the power supply board which is fed with 24 V and 5 V from the DC–DC converter of MENCA. The necessary RF voltages for mass filtering are generated by the RF board. The operation of MENCA is controlled by Onboard System for MENCA Operation and Telecommand (OSMOT) card, which is built around a 32-bit Digital Signal Processor. Figure 2 shows the block diagram of the MENCA instrument.

During scanning over the desired mass range, the ionized neutrals are mass-filtered and give rise to ion currents at different bins of the mass-to-charge ratio, resulting in a mass spectrum. For ionization with 70 eV electrons, all the parent species and their dissociative products are largely singly ionized (the probability of double ionization is less), and hence the mass-to-charge ratio axis of the mass spectrum can be approximated as the mass (along the abscissa) axis. The ordinate of the mass spectrum is fundamentally the ion current registered by the individual species, which is the measure of their respective partial pressures. Figure 3 shows a typical spectrum obtained during laboratory testing of MENCA.

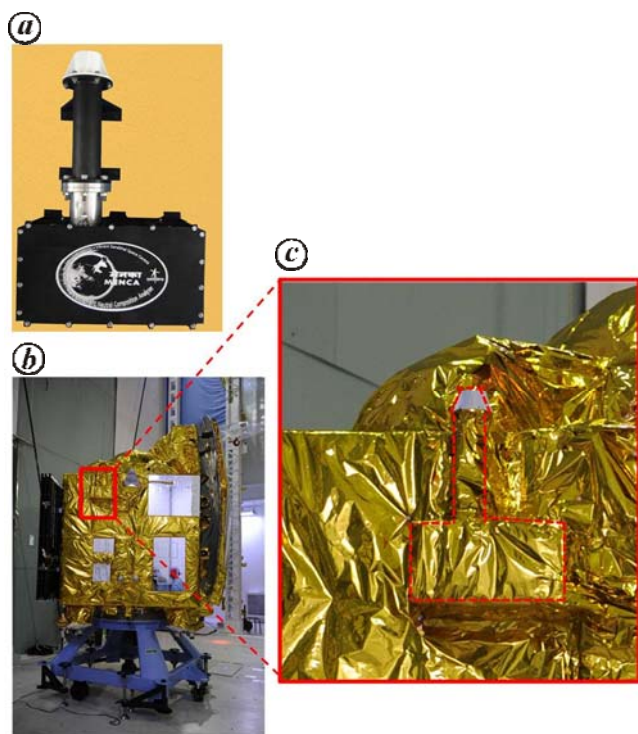

**Figure 1.** *a*, The flight model of MENCA. The cylindrical part is the sensor consisting of the ionizer section, quadrupole mass analyzer and detector assembly. The sensor is attached with the electronics (rectangular box) that controls the instrument and telemeters the data through the spacecraft. *b*, The mounting of MENCA outside the + yaw panel of the MOM as seen in the clean tent in the Sriharikota range during assembly of the spacecraft with the launch vehicle. The field-of-view of MENCA is along the + roll axis of the spacecraft. *c*, The zoomed view of the location of MENCA on MOM. The red dashed lines shows MENCA.

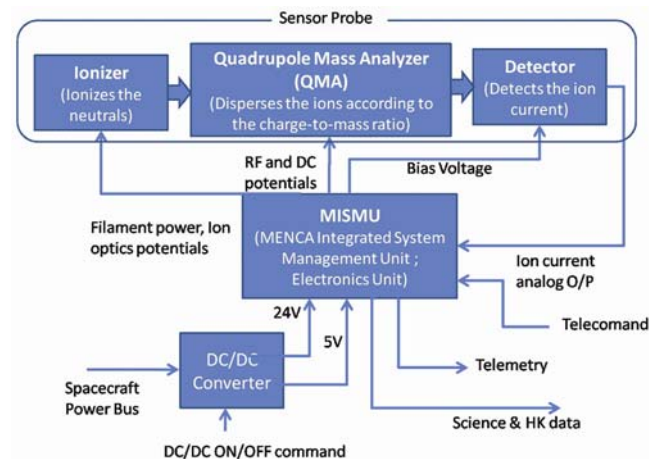

**Figure 2.** Block diagram of the MENCA instrument.

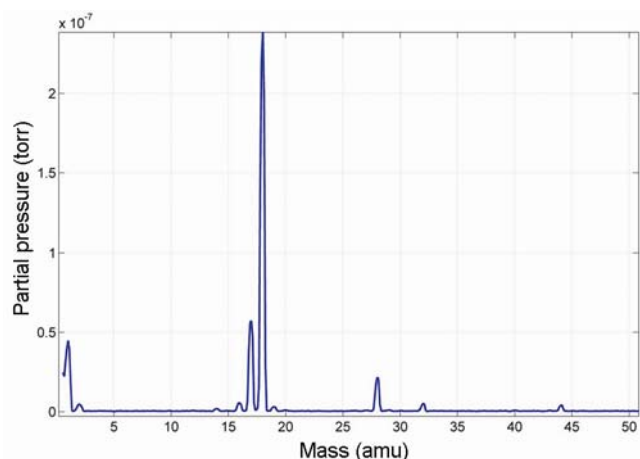

**Figure 3.** A typical mass spectrum obtained during the laboratory testing of MENCA in the mass range 1–50 amu. Signatures of H (amu 1), H<sub>2</sub> (amu 2), OH (amu 17), H<sub>2</sub>O (amu 18), N<sub>2</sub> (amu 28), O<sub>2</sub> (amu 32) and CO<sub>2</sub> (amu 44) are seen.

**Table 1.** Salient features of the MENCA instrument

Sensor	Quadrupole mass analyser, Bayard–Alpert gauge
Detector	Faraday cup and channel electron multiplier
Dynamic range	10 <sup>-4</sup> –10 <sup>-14</sup> torr for partial pressure 10 <sup>-4</sup> –10 <sup>-10</sup> torr for total pressure
Mass range	1–300 amu with 1 amu resolution, programmable
Modes of operation	Mass sweep and trend mode
Payload mass	3.56 kg (along with the power module)
Raw power consumption	29 W (nominal operations)

In addition to the mass sweep mode, where the data products are mass spectra, the instrument also operates in trend mode, where it tracks the abundances of a pre-determined set of species. Table 1 presents the salient features of the instrument.

### On-board system

The on-board software residing in the OSMOT card handles all the commanding, controlling and interface requirements of the instrument. MENCA has redundancy for command, telemetry and data interfaces. Data packet numbering and checksum are also provided for ensuring data integrity. While MENCA operates in default mode (mass sweep mode, 1–100 amu mass range with the Faraday cup detector) when powered up, there are different telecommands available with which the instrument parameters can be selected to suit the various operating requirements. MENCA is tested and qualified according to the Mars mission Environmental Test Level Specifications (ETLS)<sup>18</sup>.

The checkout system simulates the spacecraft interface for telecommands, telemetry, data and power, and studies

the responses from the instrument. The MENCA instrument is thoroughly tested for its performance using the checkout system. Figure 4 shows the telemetry, telecommand, data and power interfaces of MENCA with the spacecraft and checkout system. The MISMU contains the OSMOT and the PCCU. The payload is powered from a dual output DC–DC converter, which provides 24 V for the PCCU and 5 V for OSMOT. It also has a Checkout/JTAG Programming connectivity which is used for payload testing in the laboratory using the checkout system as well as for the programming of the on-board EEPROM and debugging of the on-board software.

The OSMOT is designed around space-qualified DSP, PROMs, EEPROM, RAM, LVDS and RS232 transceivers. The firmware for the entire operation is stored into the PROM. The major functions of OSMOT are to operate the mass spectrometer, transmit and receive data through CMOS and LVDS interfaces with the spacecraft, receive telecommand (TC), decode and execute it on an interrupt-driven basis. The important instrument parameters like mass range, scan rate, etc. can be changed through the TC in order to suit specific scientific requirements. The housekeeping parameters (e.g. temperatures and voltages) are transmitted continuously through telemetry channels of the spacecraft.

### Mechanical design

The mechanical design of the MENCA is carried out considering the following aspects:

- Structural and thermal requirements: MENCA being an electric field-based instrument, the mechanical precision and structural integrity are critical for its reliable operation. Any loss of mechanical precision gives rise to field imperfections, which affect the quality of the mass spectra as well as the throughput. Furthermore, being a neutral mass spectrometer, it consumes more power and hence the mechanical design also takes into account the efficient thermal dissipation scheme.
- Structural integrity with reference to the Mars mission ETLS.
- Compliance with the spacecraft mechanical interface definition.

The mechanical housing is configured in two parts, viz. the chassis for the MISMU and the sensor probe housing. The design is optimized taking into account the structural and thermal requirements for the payload. Finite element (FE) analysis for quasi-static loading is carried out. The results of the analysis indicate that adequate safety margins are available in this respect. Model analysis is carried out to establish that the minimum fundamental frequency of the system is more than 100 Hz.

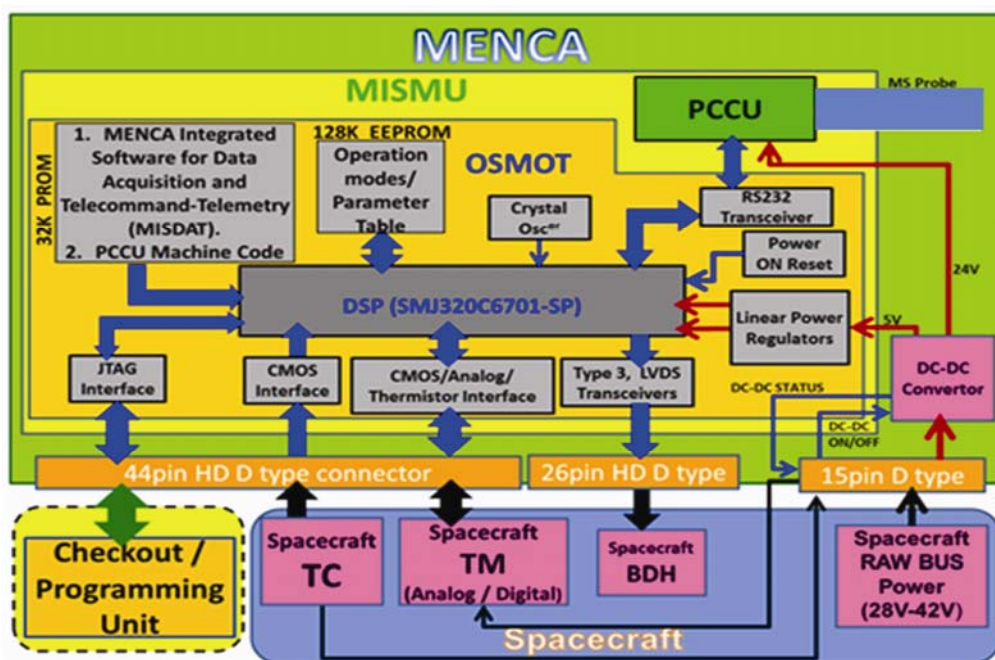

Figure 4. Block diagram of MENCA depicting the spacecraft interfaces.

## Thermal management

Thermal management scheme of MENCA instrument derives its heritage from the CHACE payload aboard the Moon impact probe (MIP) of the Chandrayaan-1 mission. Thermal management scheme of MENCA includes controlled potting, black anodization of the inner surface in order to facilitate radiative heat exchange and uniform distribution of heat in the electronics. Systematic thermal management measures are adopted in order to limit the chassis temperature to 50°C in vacuum.

The material for the fabrication of the chassis of the MENCA electronics is chosen by optimizing the payload mass and thermal management. Aluminium and magnesium alloys are two standard choices. Aluminium has a density of  $\sim 2.7 \text{ g/cm}^3$  and thermal conductivity of  $\sim 165 \text{ W/m-K}$ , while magnesium is lighter (density  $\sim 1.7 \text{ g/cm}^3$ ) but has less thermal conductivity ( $\sim 85 \text{ W/m-K}$ ) than aluminium. Due to mass constraints, magnesium alloy is used for chassis material. Hence, the chassis is suitably designed to transfer the heat away from the hotter regions to the spacecraft body. Several vacuum tests are performed at liquid nitrogen temperatures in order to study the performance of the hot cathode filament during its switch-ON. Under a vacuum of  $10^{-8}$  torr and the shroud of the vacuum chamber maintained at liquid nitrogen temperature of  $-180^\circ\text{C}$ , the hot cathode filament is switched ON and OFF multiple times to simulate the thermal shock it may experience in space during switch-ON. The MENCA instrument has three sensors to monitor the internal temperature, and two sensors to monitor the temperature at the detector assembly as well as at the

base of the MISMU chassis. One temperature sensor is mounted on the external DC-DC converter. MENCA is thermally characterized at the High Vacuum Space Simulation Facility (HVSSF) of Space Physics Laboratory (SPL), to study its thermal response for continuous operations.

## Checkout system

The ground checkout system simulates the command-response interface of MENCA with the spacecraft. It consists of a stand-alone spacecraft interface simulator hardware (SISoM, Spacecraft Interface Simulator of MENCA) and a PC-based checkout software.

SISOM is used to simulate the telemetry (TM), TC and baseband data handling (BDH) interfaces of the MENCA payload. The checkout software provides graphical user interfaces, ensures data consistency of the payload and provides the quick look display (QLD) of the data.

The MENCA checkout system has the main and redundant digital TM, the analog TM and TC as well as the main and redundant science data channels. As the science data are acquired in the high-speed mode, the redundant channel shows the raw data in background, while the on-line plot displays the processed main channel data. Figure 5 shows the schematic diagram of the MENCA checkout system.

## Designer level endurance tests

Endurance tests are conducted on MENCA proto models before firming up the qualification and flight models. The

electronic cards are subjected to radiation test in the Gamma Ray Chamber GC5000 with a Co-60 gamma ray source (average energy of the gamma rays ~1.2 MeV) at the radiation test facility at the ISRO Satellite Integration and Testing Establishment. The cards are subjected to total ionization doze (TID) of 15 krad at the rate of 0.1 rad/s.

The hot cathode filament of the MENCA sensor probe is subjected to endurance test by switching it ON and OFF for more than 100,000 cycles (20 sec period with 50% duty ratio) in an ultra-high vacuum of  $10^{-8}$  torr. Performance of the filament is checked and is found to be normal.

Continuous burn-in test for 48 hours is conducted at HVSSF at a pressure level of  $10^{-7}$  torr and the instrument performance is observed to be normal. The instrument is also subjected to cold soak test in order to qualify it for

the storage temperature of  $-20^{\circ}\text{C}$  according to the Mars mission ETLS.

### Test and evaluation

MENCA is developed with three model philosophies, i.e. engineering model (EM), qualification model (QM), and flight model (FM). The instrument is tested and qualified with respect to the Mars mission ETLS. The test sequence includes three phases, viz. initial tests conducted at standard room conditions (ISRC), environmental tests, and final tests conducted at standard room conditions (FSRC). The ISRC and FSRC tests include performance verification of the instrument in terms of its functional specifications under ultra-high vacuum of  $\sim 10^{-7}$ – $10^{-8}$  torr.

The environmental tests consist of thermal (cold and hot) soak tests in vacuum, vibration tests (pre- and post-vibration resonance survey tests, sine vibration and random vibration), thermovacuum cycling and EMI/EMC tests. Figure 6 shows the vibration test set-up for MENCA QM. Figure 7 shows the temperature profile experienced by MENCA during the thermovacuum cycling test.

### Characterization and calibration

The MENCA instrument is characterized at the pressure regime of  $\sim 10^{-7}$ – $10^{-11}$  torr. The characterization experiments are designed to arrive at the ranges of instrument operating parameters, like CEM detector bias voltage, scan rate, with the objective to maximize the signal-to-noise ratio. Several parameters, like detector linearity with bias voltage, noise as a function of the scan rate, etc. are studied during the characterization. The gain profile of the CEM detector as a function of ion mass is characterized and shown in Figure 8. The stabilization time of the hot cathode filament is characterized with respect to the electron emission current and is found to be about 25 min at a pressure of  $2 \times 10^{-11}$  torr. The results of the characterization experiments are used to choose the instrument parameter ranges and configurations for optimal

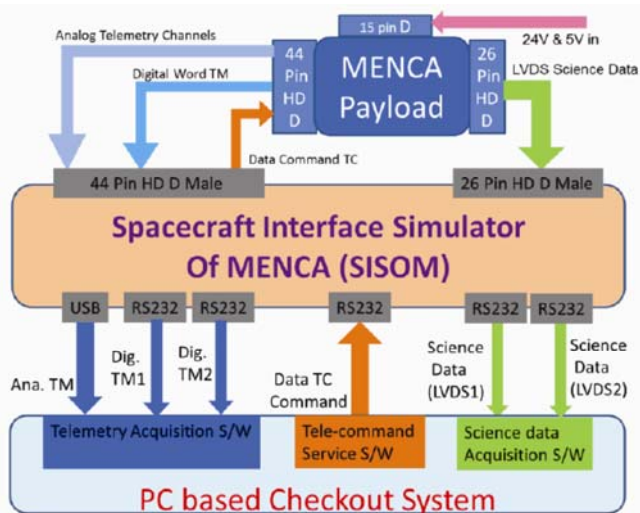

Figure 5. Schematic of the ground checkout system for the MENCA payload.

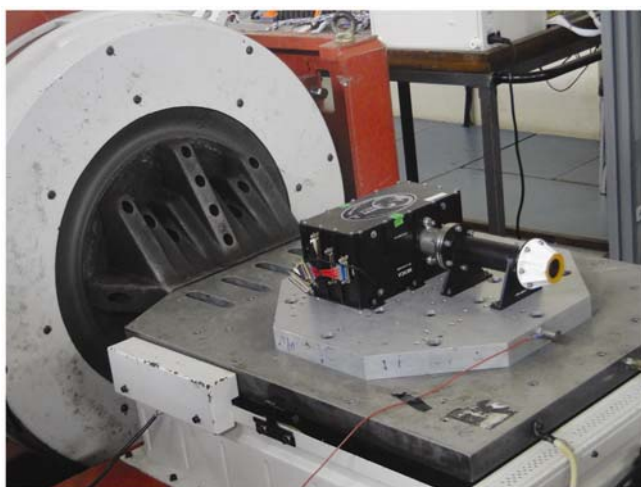

Figure 6. Vibration test set-up for the qualification model of MENCA.

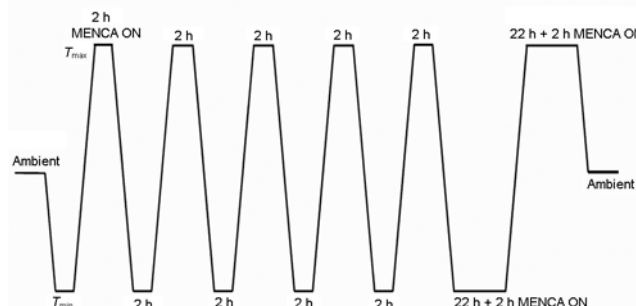
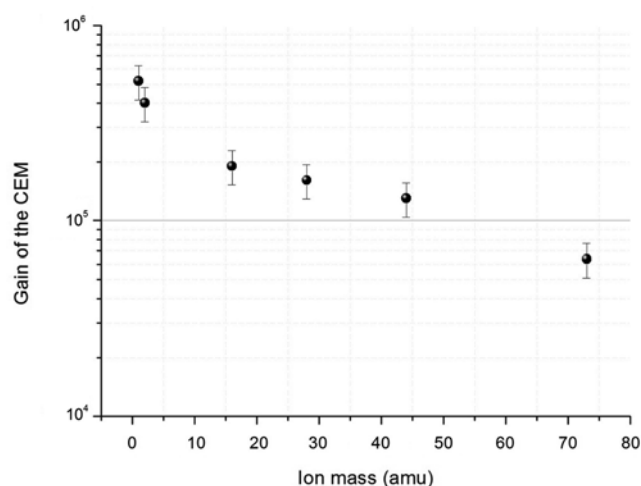

Figure 7. Temperature profile of the thermovacuum test undergone by MENCA. The temperature limits are  $T_{\min} = +5^{\circ}\text{C}$  and  $T_{\max} = +45^{\circ}\text{C}$ .

performance, as well as to obtain the mass-dependent correction factors for calculating the correct values of the relative abundances. The sensitivity of the sensor is tested at a total pressure of  $3 \times 10^{-11}$  torr, where the species with partial pressure of  $\sim 10^{-14}$  torr is detected by the CEM detector bias at 2000 V. Figure 9 displays the results.

Once MENCA is characterized and the different configurations are obtained, calibration exercises are conducted at the HVSSF by studying its response to the known levels of stimuli for the given set of operating parameters. The HVSSF comprises of a 1-m class high-vacuum chamber equipped with a dual-chain pumping system powered by turbo molecular pumps, which can attain an ultimate vacuum of  $1 \times 10^{-7}$  mbar within 4 h. The vacuum chamber in the HVSSF is equipped with mass-flow controllers, which are used to insert known gases at a controlled rate during the process of calibration of MENCA.



**Figure 8.** Laboratory characterization result of the variation of the gain of the channel electron multiplier (CEM) detector with mass of the incident ion.

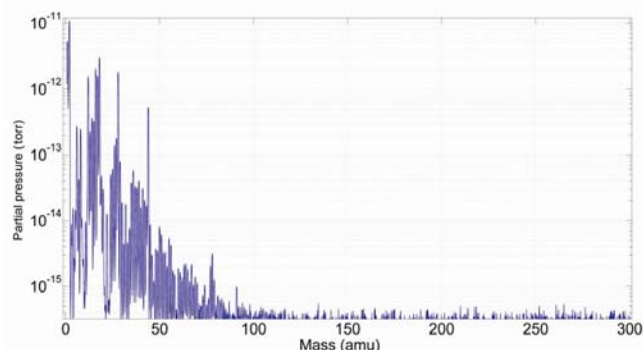
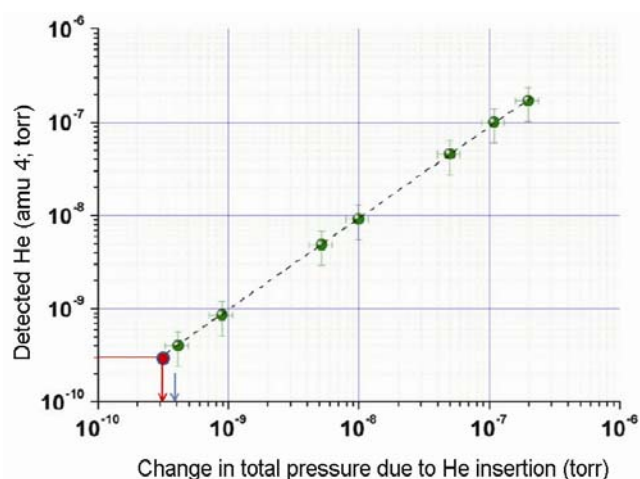

**Figure 9.** Mass spectrum obtained during laboratory characterization at a total pressure of  $3 \times 10^{-11}$  torr to demonstrate the performance of the instrument. Species with partial pressures of  $\sim 10^{-14}$  torr are detected. Combination of titanium sublimation pump and sputter ion pump was used to achieve the ultra-high vacuum.

The calibration is carried out with respect to a reference mass spectrometer, which in turn, is calibrated in the pressure range  $10^{-6}$ – $10^{-11}$  torr at the UHV Division of Raja Ramanna Centre for Advanced Technology (RRCAT), Indore. The reference mass spectrometer is mass-calibrated with respect to a few gases like He, Ar, Xe, Kr, N<sub>2</sub> and CO<sub>2</sub>. The pressure calibration is done up to the total pressure of  $10^{-11}$  torr. MENCA is calibrated against the reference mass spectrometer for the partial pressure, total pressure and mass peak accuracy. The standard residual gases in the vacuum chamber (e.g. H, H<sub>2</sub>, N, O, OH, H<sub>2</sub>O, N<sub>2</sub> and O<sub>2</sub>) as well as few known gases (He, Ar, N<sub>2</sub> and CO<sub>2</sub>) are used for the calibration of MENCA at HVSSF.

The differential response of MENCA is studied in order to establish the detector linearity, where He gas is inserted in controlled steps and increase in the total pressure (measured with an independent ionization gauge, with suitable gas correction factor for the He gas) and the corresponding increase in the height of the He peak are continuously measured. The resulting calibration curve (Figure 10) is used to estimate an unknown amount of He gas inserted in the vacuum chamber and the detected value matches with the increase in the total pressure.

MENCA is calibrated thrice; first before the test and evaluation; secondly, after the test and evaluation and finally, before its shipment from the Vikram Sarabhai Space Centre (VSSC), Thiruvananthapuram to ISRO Satellite Centre (ISAC), Bengaluru. No deviation is observed in the three calibrations. Figure 11 shows a residual gas spectrum obtained by MENCA during its mass calibration.



**Figure 10.** Study of the response of MENCA by insertion of helium gas in steps in the partial pressure range  $10^{-10}$ – $10^{-7}$  torr. After experimentally obtaining the calibration curve (shown with dotted lines), a controlled amount of helium gas is inserted in the vacuum chamber and its partial pressure is estimated (shown with red arrow). The estimated value of the partial pressure of the inserted helium gas is found to be in agreement (within the error bar) with the actual amount (shown with blue arrow) of the partial pressure of helium inserted in the chamber.

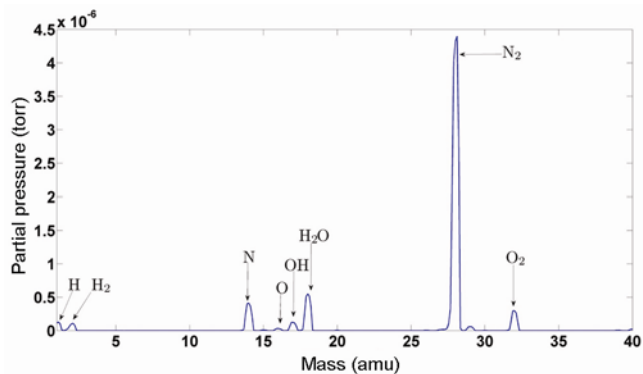

**Figure 11.** Mass calibration of MENCA flight model with reference to the prominent constituents in a residual gas environment and their dissociation products.

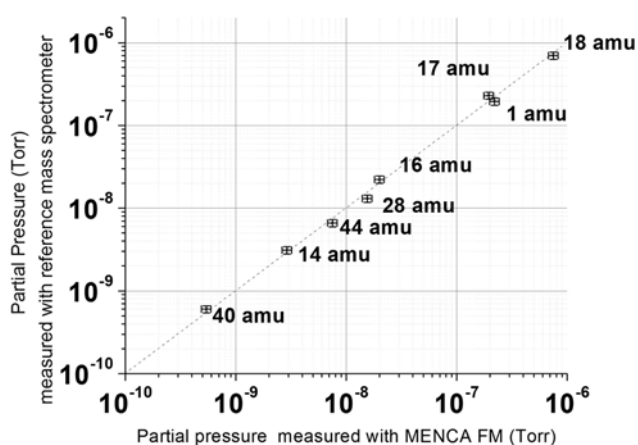

**Figure 12.** Scatter diagram showing the results of the absolute partial pressure (torr) calibration of MENCA flight model (FM) against the reference mass spectrometer with reference to the residual gases in the vacuum chamber at a pressure level of  $1.3 \times 10^{-6}$  torr. The correlation coefficient between two measurements is 0.989, indicating a good match between MENCA and the reference mass spectrometer values. Cross-error bars are shown for each data point.

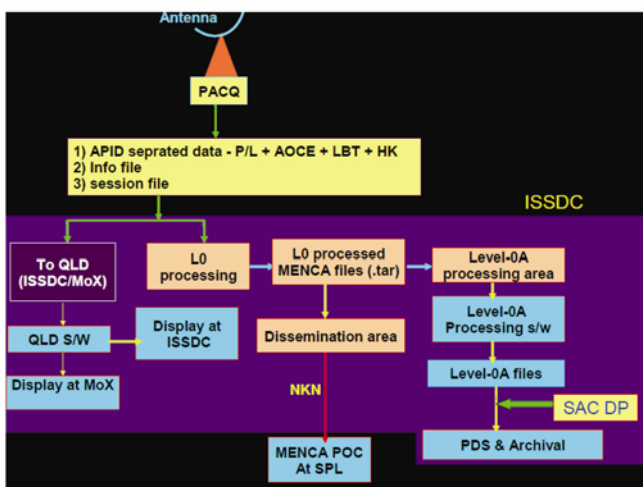

**Figure 13.** Schematic of MENCA data flow at ground and the various levels of data processing and data dissemination.

The Bayard–Alpert gauge of MENCA is also calibrated against a reference gauge in the pressure range  $10^{-5}$ – $10^{-9}$  torr. Figure 12 presents the scatter diagram corresponding to the final calibration exercise of MENCA showing the partial pressure measurements with MENCA and the reference mass spectrometer. Each point in the scatter diagram represents a mean of 20 measurements.

### The payload operation centre

The Payload Operation Centre (POC) for MENCA has been set up in SPL, VSSC. The POC is responsible for the overall science operations of MENCA, reception of the science and housekeeping (HK) data from the Indian Space Science Data Centre (ISSDC), regular monitoring of real-time HK parameters of MENCA as well as data analysis. The interface from POC to ISSDC is through the National Knowledge Network (NKN). This link is used to receive the payload data from ISSDC and send the telecommand files for science operation of MENCA. POC is equipped with storage systems and workstations for the analysis of MENCA data.

MENCA data from the mission are archived in Planetary Data System (PDS) standards. The development of the pipeline for MENCA data archival is a collaborative activity between the SPL archival team and the Data Processing (DP) team of the Space Applications Centre (SAC), Ahmedabad. The pipeline for the active PDS archive of MENCA data has been developed and established at ISSDC. Figure 13 shows the flow diagram of MENCA data dissemination and processing pathway.

### Summary

The MENCA experiment aboard MOM will measure *in situ* the composition of the neutral exosphere and its radial distribution. It is a quadrupole mass spectrometer-based instrument meant to detect the thermal neutrals in the Martian exosphere. MENCA is developed adopting a three-model philosophy and has undergone all the mandatory tests according to the Mars mission ETLs. The instrument is ground-calibrated with respect to residual gases in ultra-high vacuum as well as by inserting known gases in the test chamber. To test the functionality of the instrument, MENCA is operated once in the Earth-bound phase and a few times during the heliocentric phase of the mission. After insertion of MOM in Mars orbit on 24 September 2014, MENCA was operated for the first time on 29 September 2014. Subsequently, the high-voltage commissioning of the MENCA has been conducted. The instrument is healthy and the performance is normal.

1. Lammer, H. *et al.*, Outgassing history and escape of the Martian atmosphere and water inventory. *Space Sci. Rev.*, 2003, **174**, 113–154.

2. Dennerl, K. *et al.*, First observation of Mars with XMM Newton. High resolution X-ray spectroscopy with RGS. *Astron. Astrophys.*, 2006, **451**, 709–722; doi:10.1051/0004-6361:20054253.
3. Neir, A. O. *et al.*, Composition and structure of the Martian atmosphere: preliminary results from Viking 1. *Science*, 1976, **193**, 786–788.
4. Nier, A. O. and McElroy, M. B., Structure of the neutral upper atmosphere of Mars: results from Viking 1 and Viking 2. *Science*, 1976, **194**, 1298–1300.
5. Kallio, E., Chaufray, J. V., Modolo, R., Snowden, D. and Winglee, R., Modeling of Venus, Mars and Titan. *Space Sci. Rev.*, 2011, **162**, 267–307.
6. Chaufray, J. Y., Bertaux, J. L., Leblanc, F. and Quémerais, E., Observation of the hydrogen corona with SPICAM on Mars Express. *Icarus*, 2008, **195**(2), 598–613.
7. Chaufray, J. Y., Leblanc, F., Quemerais, E. and Bertaux, J. L., Martian oxygen density at the exobase deduced from O I 130.4-nm observations by SPICAM on Mars Express. *J. Geophys. Res. (Planets)*, 2009, **114**, E02006, doi:10.1029/2008JE003130.
8. Bruinsma, S., Forbes, J. M., Marty, J. C., Zhang, X. and Smith, M. D., Long-term variability of Mars' exosphere based on precise orbital analysis of Mars Global Surveyor and Mars Odyssey. *J. Geophys. Res. Planets*, 2014, **119**, 210–218.
9. Feldman, P. D. *et al.*, Rosetta-Alice observations of exospheric hydrogen and oxygen on Mars. *Icarus*, 2013, **214**, 394–399.
10. Krasnopolsky, V. A. and Gladstone, G. R., Helium on Mars: EUVE and PHOBOS data and implications for Mars' evolution. *J. Geophys. Res.*, 1996, **101**, 15765–15772.
11. Fox, J. L., Response of the Martian thermosphere/ionosphere to enhanced fluxes of solar soft X-rays. *J. Geophys. Res.*, 2004, **109**, A11310.
12. Chaufray, J. Y., Modolo, R., Leblanc, F., Chanteur, G., Johnson, R. E. and Luhmann, J. G., Mars solar wind interaction: formation of the Martian corona and atmospheric loss to space. *J. Geophys. Res.*, 2007, **112**, E09009; doi:10.1029/2007JE002915.
13. Yagi, M., Leblanc, F., Chaufray, J. Y., Gonzalez-Galindo, F., Hess, S. and Modolo, R., Mars exospheric thermal and non-thermal components: seasonal and local variations. *Icarus*, 2012, **221**, 682–693.
14. Sridharan, R., Ahmed, S. M., Das, T. P., Sreelatha, P., Pradeepkumar, P., Naik, N. and Supriya, G., Direct evidence of water (H<sub>2</sub>O) in the sunlit lunar ambience from CHACE on MIP of Chandrayaan-1. *Planet. Space Sci.*, 2010, **58**, 947–950.
15. Sridharan, R., Das, T. P., Ahmed, S. M. and Bhardwaj, Anil, Indicators for localized regions of heavier species in the lunar surface from CHACE on Chandrayaan-1. *Curr. Sci.*, 2013, **105**(11), 1470–1472.
16. Sridharan, R., Das, T. P., Ahmed, S. M., Supriya, Gogulapati, Bhardwaj, Anil and Kamalakar, J. A., Spatial heterogeneity in the radiogenic activity of the lunar interior: inferences from CHACE and LLRI on Chandrayaan-1. *Adv. Space Res.*, 2013, **51**, 168–178.
17. Thampi, S. V., Sridharan, R., Das, T. P., Ahmed, S. M., Kamalakar, J. A. and Bhardwaj, Anil, The spatial distribution of molecular hydrogen in the lunar atmosphere – new results. *Planet. Space Sci.*, 2015, **106**, 142–147; <http://dx.doi.org/10.1016/j.pss.2014.12.018>
18. Mars Orbiter Mission environmental level specifications, ISRO-ISAC-MOM-PR-2063. ISRO internal document with restricted access, December 2012.

ACKNOWLEDGEMENTS. We thank the Director, VSSC; Director (R&D), VSSC; the Payload Review and Clearance Board (PRCB), and various other review committees, as well as the Quality Assurance, Quality Control, Test and Evaluation, and Configuration Control teams for their valuable suggestions and guidance throughout the realization of MENCA. We thank the members of the System Reliability, Avionics and Aeronautics entities of VSSC for their contributions and the support of the personnel of the Environmental Test Facility, vibration laboratory and EMI/EMC laboratory. We also thank the MOM project, Project Director, and the IRS Program Director and other groups at ISAC for their support and Mission operation, ISSDC and ISTRAC teams for help during the on-board operations of MENCA. The UHV Division of RRCAT, Indore, is acknowledged for extending support for the calibration of the reference mass spectrometer.

doi: 10.18520/v109/i6/1106-1113