

A NEW HYBRID DIVERSITY COMBINING SCHEME FOR MOBILE RADIO COMMUNICATION SYSTEMS OVER NAKAGAMI FADING CHANNEL

Akinyinka Olukunle Akande, Onyebuchi Chikezie Nosiri, Nnaemeka Chiemezie Onuekwusi and Emmanuel Uchenna Ekwueme

Department of Electrical and Electronic Engineering,
Federal University of Technology Owerri, Imo State, Nigeria

ABSTRACT

Diversity combining is a technique in wireless network that uses multiple antenna system to improve the quality of radio signal. Mobile radio system suffers multipath propagation due to signal obstruction in the channel. A new hybridized diversity combining scheme consisting of Equal Gain Combining (EGC) and Maximal Ratio Combining (MRC) was proposed in this paper. The performance of the hybrid model was evaluated using Outage Probability (P_{out}) and Processing time (P_t) at different Signal-to-Noise Ratio (SNR) and Signal Paths ($L=2,3$) for 4-QAM and 8-QAM Modulation Schemes. A mathematical expression for the hybrid EGC-MRC was realized using the Probability Density Function (PDF) of the Nakagami fading channel. MATLAB R2015b software was used for the model simulation. The result shows that hybrid EGC-MRC outperforms the standalone EGC and MRC schemes by having lower P_{out} and P_t values. Hence, hybrid EGC-MRC exhibits enhanced potentials to mitigate multipath propagation at reduced system complexity.

KEYWORDS

Equal Gain Combining (EGC), Nakagami, Outage Probability, Processing Time, Multipath, Hybrid

1. INTRODUCTION

The wireless communications industry has experienced considerable popularity in the past few years because of many services available in mobile radio system [1]. The wireless communication systems suffer from problems introduced by multipath propagation fading and shadowing effects such as signal attenuation and path loss [2]. The signal fading is due to rapid fluctuation of signals in the mobile wireless channel as a result of shadowing from obstacles which brings about multiple copies of signals transmitted to the receiver over short period of time [3]. The interference between two or more mobile wireless signals which arrives the receiver at slightly different time resulted to signal fading. In order to cushion the effect of signal attenuation in the wireless system due to obstructions in the communication channel, fading compensation scheme is required. The diversity scheme is used to combat multipath propagation in wireless system when multiple copies of Radio Signal (RS) produced in the channel are sent to the receiver. The multiple signals are combined using various diversity combining schemes in order to compensate for signal loss in the channel.

In wireless system, different diversity schemes are deployed to solve the problem of poor received signal and to obtain better network performance in mobile radio system [4]. Diversity

scheme combine signals suffering from multipath propagation to obtain a reliable and improved output signal [5]. Some of the frequently used fading channel model in wireless communication system are Weibull, Rician, Rayleigh and Nakagami [6]. The Rayleigh fading channel is applicable to a scenario where no clear Line-of-Sight (NLOS) path exist in the channel [7]. The Rician distribution mostly applicable to a situation where clear Line-of-Sight (LOS) exist in the communication system. The Nakagami fading channel combine the characteristics of both Rayleigh communication channel and Rician communication channel [8]. The commonly used existing diversity combining schemes applicable in wireless systems are Maximal Ratio Combining (MRC), Selection Combining (SC), Equal Gain Combining (EGC) and Threshold Combining (TC) [9].

These conventional diversity combiners such as MRC and EGC utilize multiple Radio Frequency (RF) chain and many filters which made the model to suffer hardware complexity at the receiver [10]. The most commonly used hybrid diversity schemes are Hybrid Selection/Equal Gain Combining (SC-EGC) and Selection - Maximal Ratio Combining (SC-MRC) [11]. The hybrid diversity scheme EGC-MRC in cellular radio system has not been proposed in previous works reviewed. The development of a new hybrid diversity scheme was carried out in this paper primarily to mitigate the effect of multipath fading in wireless system. The outage probability and processing time was used to evaluate the performance of the hybrid model. The modulation schemes are used to encode and protect the signal against unwanted noise in mobile radio channel [12]. The Quadrature Amplitude Modulation (QAM) modulation scheme was deployed with hybrid EGC-MRC diversity technique at the receiver with single Radio Frequency (RF) chain and Matched Filter (MF) to obtain non-overlapping signal at the receiver front end.

2. RELATED WORKS

The authors of [3], presented diversity technique, a hybrid of Maximal Ratio Combining (MRC) and Selection Combining (SC) schemes over two Waves with Diffuse Power (WDP) communication channel. The proposed model reported to be good but suffers high hardware complexity. In [2], worked on hybrid SC-MRC system in Rayleigh communication channel. The results obtained showed that MRC-SC scheme provided good performance compared to Selection Combining (SC), but suffered high hardware complexity. [11] investigated the performance of the MRC-SC as hybrid diversity scheme in Rayleigh communication channel. It was reported that MRC-SC had a better performance by selecting branch with highest SNR, but with high hardware complexity. The works of [13], proposed a hybrid diversity scheme in wireless radio network using Binary Phase-Shift Keying (BPSK) modulation for Single Input-Multiple Output (SIMO) in mobile communication channel.

The SC and MRC was hybridized for signal transmission. The Bit-Error-Rate (BER) for SC-MRC diversity combiner and other three conventional diversity techniques (i.e. SC, MRC, EGC) were computed and simulated. The result showed that at low bit rate, the Hybrid SC-MRC diversity scheme performed better than the conventional diversity combiner at lower values of SNR. Also, at high bit rate, the hybrid SC-MRC diversity combiner outperforms MRC for all values of SNR. The model suffers high hardware complexity due to multiple output with Radio Frequency (RF) chain and filters that can lead to increase in cost. In [14], presented the analysis of diversity combiner in SIMO multicasting wireless network over Rayleigh communication channel. The mathematical expressions were derived for the Probability Density Function (PDF) and Cumulative Distribution Function (CDF) of the multicast capacity with and without applying diversity scheme. These parameters such as PDF, CDF and Complementary Cumulative Distribution Function (CCDF) were applied with SC and MRC to obtain multicast capacity expression. The results obtained from the combining scheme was presented. MRC gave better performance than the SC scheme though suffered high hardware complexity.

3. SYSTEM MODEL

In the proposed EGC-MRC hybrid model, the signals are transmitted over Nakagami communication channel. The randomly generated bits are modulated using 4-QAM and 8-QAM modulation schemes. The base band signals from the transmitters are received by multiple EGC antenna having N diversity branches. These N branches of the EGC select and combine signals with equal gains with respect to the set threshold value. The output signal from EGC was received by K branches of MRC combiner. The MRC accept only the branches that produced signal power above or equal to the set threshold value. These K signal powers are combined and the mean value was obtained to give maximum value of SNR as the output signal. The output signal from EGC-MRC hybrid model passed through single RF chain and single MF to the receiver. The proposed system block diagram is represented in Figure 1.

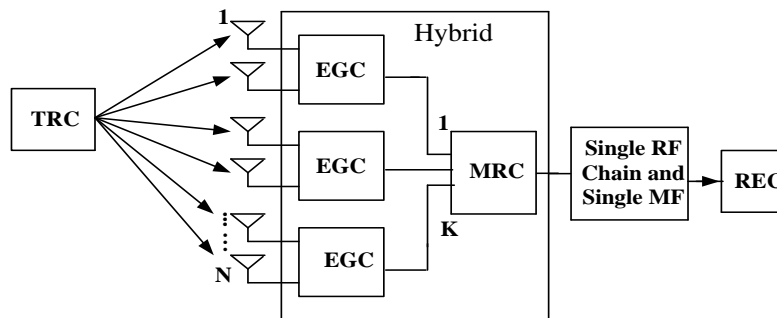

Figure1: The Proposed model for the hybrid MRC-EGC combiner

4. MATHEMATICAL EXPRESSIONS FOR EGC DIVERSITY COMBINING

The N-branch Equal Gain Combiner (EGC) receiver over Nakagami environment is considered. The output of the combiner is the instantaneous SNR of the EGC as presented in equation (1) as: [15].

$$Y_{EGC}(Y_z) = \frac{Y^{N_p-1} e^{-Y/\bar{Y}}}{\bar{Y} \Gamma(m)} \quad (1)$$

where;

$Y_{EGC}(Y_z)$ is the output instantaneous SNR

\bar{Y} is the average SNR of received signal

Y is the SNR of received signal

$\Gamma(m)$ is the Gamma function

N_p is the Number of signal paths

4.1. Probability Density Function (PDF)

The PDF of the combiner is presented in equation (2) as: [16].

$$Pdf_{EGC}(Y_z) = \frac{1}{\bar{Y}_v} * e^{-2\frac{Y_z}{\bar{Y}_v}} + \sqrt{\pi} * e^{-\frac{Y_z}{\bar{Y}_v}} * [A(k, sf)] \quad (2)$$

where;

$$[A(k, sf)] = \left(\frac{1}{2(\bar{\gamma}_v \gamma_z)^{\frac{1}{2}}} - \frac{1}{\bar{\gamma}_v} \left(\frac{\gamma_z}{\bar{\gamma}_v} \right)^{\frac{1}{2}} \right)$$

$\bar{\gamma}_v$ = the average SNR of the combiner

γ_z =the output instantaneous SNR of EGC

Substituting the instantaneous SNR in equation (1) into PDF of EGC diversity combiner given in equation (2). The overall PDF of EGC is given in equation (3) as;

$$Pdf_{EGC}(\gamma_z) = \frac{1}{\bar{\gamma}_v} e^{-2 \frac{\gamma^{Np-1} e^{-\gamma/\bar{\gamma}}}{\bar{\gamma} \Gamma(m)}} + \sqrt{\pi} e^{-\frac{\gamma^{Np-1} e^{-\gamma/\bar{\gamma}}}{\bar{\gamma} \Gamma(m)}} * [A(k, sf)] \quad (3)$$

where,

$$A(k, sf) = \left(\frac{1}{2(\bar{\gamma}_v \gamma_{EGC}(\gamma_z))^{\frac{1}{2}}} - \frac{1}{\bar{\gamma}_v} \left(\frac{\gamma_{EGC}(\gamma_z)}{\bar{\gamma}_v} \right)^{\frac{1}{2}} \right)$$

4.2. Outage Probability (P_{out})

The Outage Probability (P_{out}) of the signal in EGC is the integral of PDF with threshold value as the maximum limit [15], [16]. This is presented in equation (4) as;

$$P_{out} = \int_0^{\gamma_0} Pdf_{EGC}(\gamma_z) d\gamma \quad (4)$$

By Substituting equation (3) into (4) and equation (5) is presented in integral form as;

$$P_{out}(EGC) = \int_0^{\gamma_0} \left[\frac{1}{\bar{\gamma}_v} e^{-2 \frac{\gamma^{Np-1} e^{-\gamma/\bar{\gamma}}}{\bar{\gamma} \Gamma(m)}} + \sqrt{\pi} e^{-\frac{\gamma^{Np-1} e^{-\gamma/\bar{\gamma}}}{\bar{\gamma} \Gamma(m)}} + [A(k, sf)] \right] d\gamma \quad (5)$$

where,

$$[A(k, sf)] = \left(\frac{1}{2(\bar{\gamma}_v \gamma_{EGC}(\gamma_z))^{\frac{1}{2}}} - \frac{1}{\bar{\gamma}_v} \left(\frac{\gamma_{EGC}(\gamma_z)}{\bar{\gamma}_v} \right)^{\frac{1}{2}} \right)$$

γ_0 is the threshold value

γ is the SNR of received signal

5. MATHEMATICAL EXPRESSIONS FOR MRC DIVERSITY

The K-branch MRC diversity receiver operating in Nakagami fading communication channel is considered to obtain maximum signal level that is fed into single RF chain and Match filter. The output of the combiner is the instantaneous SNR of the MRC diversity receiver given as: [15].

$$\gamma_{MRC}(\gamma_x) = \frac{\gamma^{k-1} e^{-\gamma/\bar{\gamma}}}{\bar{\gamma}^k (k-1)!} \quad (6)$$

where;

$Y_{MRC}(Y_x)$ is instantaneous SNR output for MRC

l is the number of branches

$\bar{\gamma}$ is average SNR of received signal

K is the Number of signal paths

5.1. Probability Density Function of MRC

The Probability Density Function for MRC (PDF_{MRC}) with K -number of branches given in equation (7) as: [17].

$$Pdf_{MRC}(Y_x) = \frac{Y_{MRC}(Y_x)^{K-1}}{(K-1)!(\bar{\gamma}_{av})^K} + \sqrt{\pi} \exp\left(-\frac{Y_{MRC}(Y_x)}{\bar{\gamma}_{av}}\right) \quad (7)$$

Substituting the instantaneous SNR in equation (6) into PDF of MRC diversity combiner in equation (7). The overall Pdf_{MRC} of MRC is represented as:

$$Pdf_{MRC}(Y_x) = \frac{\left(\frac{\gamma^{K-1} e^{-\gamma/\bar{\gamma}}}{\bar{\gamma}^{k(k-1)!}}\right)^{K-1}}{(K-1)!(\bar{\gamma}_{av})^K} + \sqrt{\pi} \exp\left(-\frac{\frac{\gamma^{K-1} e^{-\gamma/\bar{\gamma}}}{\bar{\gamma}^{k(k-1)!}}}{\bar{\gamma}_{av}}\right) \quad (8)$$

where;

$Pdf_{MRC}(Y_x)$ = the pdf of MRC

$\bar{\gamma}$ = the average SNR of received signal

γ = the SNR of received signal

$\bar{\gamma}_{av}$ = the average SNR of the combiner

k = the number of branches

5.2. Outage Probability for MRC

The outage probability of MRC, $P_{out}(MRC)$ is given as the integral of pdf as presented in equation (9) as: [15], [16].

$$P_{out} = \int_0^{\gamma_0} Pdf_{MRC}(Y_t) d\gamma \quad (9)$$

Substituting equation (8) into equation (9) to produce integral of equation (10) as;

$$P_{out}(MRC) = \int_0^{\gamma_0} \frac{\left(\frac{\gamma^{k-1} e^{-\gamma/\bar{\gamma}}}{\bar{\gamma}^{k(k-1)!}}\right)^{k-1}}{(k-1)!\bar{\gamma}_{av}^k} + \sqrt{\pi} \exp\left(-\frac{\frac{\gamma^{k-1} e^{-\gamma/\bar{\gamma}}}{\bar{\gamma}^{k(k-1)!}}}{\bar{\gamma}_{av}}\right) d\gamma \quad (10)$$

where,

$P_{out}(MRC)$ is the outage probability of MRC

γ_0 is the set threshold

γ is SNR of received signal

5.3. The Developed Hybrid Model

The closed form expression for the developed hybrid EGC/MRC is combination of the PDFs of EGC and MRC diversity scheme. Thus, the PDF of the developed hybrid model is given in equation (11) as:

$$Pdf_{EGC/MRC}(\gamma_t) = Pdf_{EGC}(\gamma_z) * Pdf_{MRC}(\gamma_x) \quad (11)$$

where;

$\gamma_{EGC}(\gamma_z)$ is the instantaneous SNR output for EGC
 $\gamma_{MRC}(\gamma_x)$ is instantaneous SNR output for MRC

by substituting equations (3) and (8) into equation (11) to produce equation (12). The simulation of the new hybrid EGC-MRC was carried out using MATLAB R2015b software

$$Pdf_{EGC/MRC}(\gamma_t) = \{Z(k, ny) + A(k, sf)\} * [B(k, rl)] \quad (12)$$

where:

$$Z(k, ny) = \frac{1}{\bar{\gamma}_v} e^{-2 \frac{\gamma_{EGC}(\gamma_z)}{\bar{\gamma}_v}} + \sqrt{\pi} e^{-\frac{\gamma_{EGC}(\gamma_z)}{\bar{\gamma}_v}}$$

$$A(k, sf) = \left(\frac{1}{2(\bar{\gamma}_v \gamma_{EGC}(\gamma_z))^{\frac{1}{2}}} - \frac{1}{\bar{\gamma}_v} \left(\frac{\gamma_{EGC}(\gamma_z)}{\bar{\gamma}_v} \right)^{\frac{1}{2}} \right)$$

$$B(k, rl) = \frac{(\gamma_{MRC} \gamma_x)^{k-1}}{(k-1)! (\bar{\gamma}_{av})^k} + \sqrt{\pi} \exp\left(-\frac{\gamma_{MRC}(\gamma_x)}{\bar{\gamma}_{av}}\right)$$

6. PERFORMANCE METRICS FOR EGC- MRC RECEIVER

The Outage Probability (P_{out}) and Processing Time (P_t) are the metrics deployed to evaluate the suitability of the new hybrid model in Nakagami environment. The (P_{out}) describes the probability at which the SNR of the received signal falls below a given threshold while the (P_t) is the time taken by a propagating signal to travel from source to the destination measured in seconds

6.1. Outage Probability of EGC-MRC

This is the probability that output SNR (γ) will fall below a specified threshold value (γ_0) given as: [16].

$$P_{out} = \int_0^{\gamma_0} P_\gamma(\gamma) d\gamma \quad (13)$$

The outage probability of the new Hybrid model is presented in equation (14) as:

$$P_{out}(EGC/MRC) = \int_0^{\gamma_0} Pdf_{EGC}(\gamma_z) * Pdf_{MRC}(\gamma_x) d\gamma \quad (14)$$

Substituting equation (5) and equation (10) into equation (14) to have equation (15) produces the new hybrid outage probability model deployed.

$$P_{out}(EGC/MRC) = \int_0^{\gamma_0} \left[\frac{1}{\bar{\gamma}_{av}} e^{-2\frac{\gamma_{EGC}(\gamma_z)}{\bar{\gamma}_{av}}} + \sqrt{\pi} e^{-\frac{\gamma_{EGC}(\gamma_z)}{\bar{\gamma}_{av}}} * B(k, sf) \right] * C(k, rl) d\gamma(15)$$

where:

γ_0 is the set threshold

$\gamma_{EGC}(\gamma_t)$ is the instantaneous SNR output for EGC

$\gamma_{MRC}(\gamma_t)$ is instantaneous SNR output for MRC

7. SIMULATION PARAMETERS

The simulation of the hybrid model and conventional models were carried out using MATLAB R2015b software. The choice of the software was due to low cost implementation compared with the field test measurements. The online random generated binary data with 4-QAM and 8-QAM modulation schemes were used for the simulation. Table 1 shows the parameters implemented in the simulation.

Table 1: Simulation parameters

Parameters	Variables
Modulation scheme (M)	4-QAM, 8-QAM
Fading channel	Nakagami
No of paths (L)	2,3
Carrier Frequency (Fc)	2.3GHz
Noise	AWGN
Line of Sight Component (k)	3
SNR	2 dB – 10 dB
Data length	20,000
(Set threshold) γ_0	2.0 dB
Base Station power	1 watts

8. DISCUSSION OF THE RESULTS

The results of Outage Probability (P_{out}) and Processing time (P_t) were obtained for EGC, MRC and hybrid EGC-MRC model at different SNR and 2.3 GHz frequency.

Figure 2 shows the plot of P_{out} values against different SNR. At L=2 and 4-QAM modulation scheme, the P_{out} values for EGC were 0.35 dB, 0.19 dB, 0.13 dB, 0.10 dB and 0.09 dB at SNR of 2, 4, 6, 8, and 10 respectively, while the corresponding values of P_{out} for MRC were 0.22 dB, 0.10 dB, 0.07 dB, 0.05 dB and 0.04 dB. The Hybrid EGC/MRC shows a better performance compared to EGC and MRC with P_{out} values of 0.07 dB, 0.02 dB, 0.009 dB, 0.006 dB and 0.004 dB at different SNR.

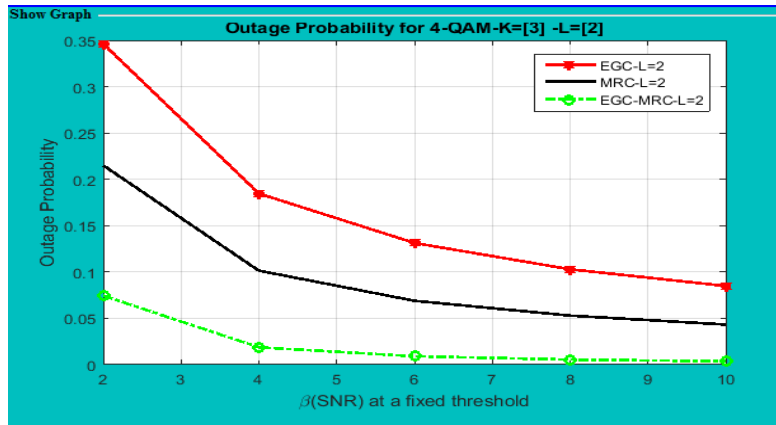

Figure 2: Outage Probability against SNR for EGC, MRC and hybrid EGC/MRC at L=2 and 4-QAM Modulation Scheme

Figure 3 presents the comparative plot of processing time against SNR at a fixed threshold value. At $L = 2$ and 4-QAM modulation scheme, the P_t values for EGC were 1.02sec, 1.03sec, 1.03sec, 1.03sec and 1.03sec at SNR of 2, 4, 6, 8, and 10 respectively, while the values of P_t for MRC were 0.91sec, 0.92sec, 0.92sec, 0.92sec and 0.92. The Hybrid EGC-MRC performance better than EGC and MRC with P_t values of 0.78sec, 0.79sec, 0.79sec, 0.79sec and 0.79sec at different SNR. The developed hybrid model gave lower processing time compare to conventional diversity combining.

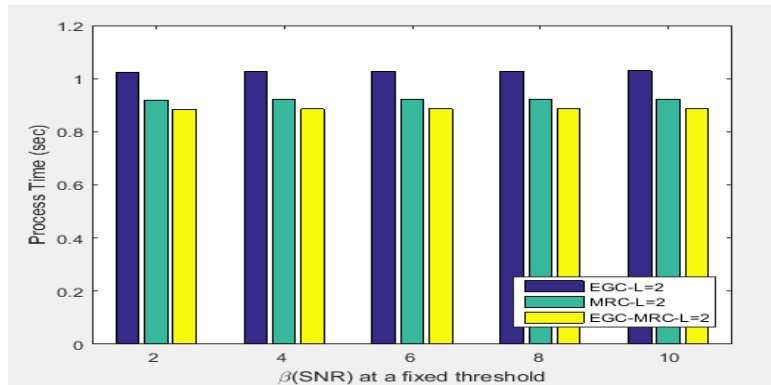

Figure 3: Plot of Processing Time against SNR for EGC, MRC and hybrid EGC/MRC at L=2 and 4-QAM Modulation Scheme

Figure 4 shows Outage Probability (P_{out}) values against different SNR. At $L = 3$ and 4-QAM modulation scheme, the P_{out} values for EGC were 0.35 dB, 0.14 dB, 0.08 dB, 0.06 dB and 0.04dB at SNR of 2, 4, 6, 8, and 10 respectively, while P_{out} corresponding values of MRC were 0.17 dB, 0.07dB, 0.04 dB, 0.03 dB and 0.022 dB. The Hybrid EGC/MRC gave better performance compared to EGC and MRC with P_{out} values of 0.06 dB, 0.009 dB, 0.003 dB, 0.002 dB and 0.0009 dB at SNR of 2, 4, 6, 8, and 10 respectively.

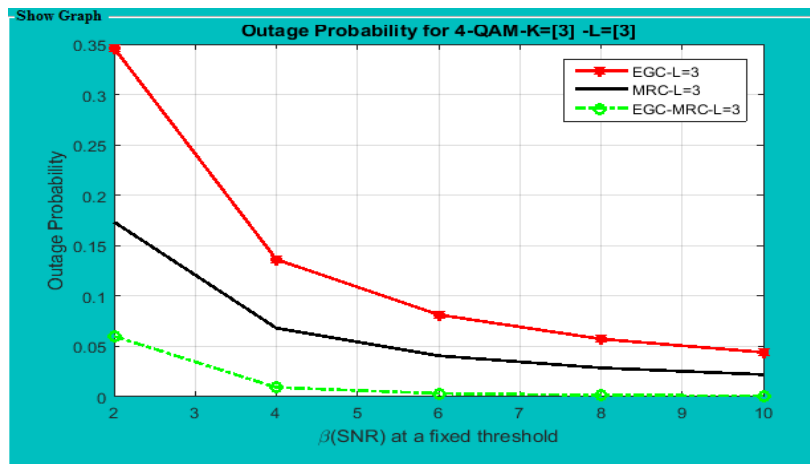

Figure 4: Outage Probability against SNR for EGC, MRC and hybrid EGC/MRC at L=3 and 4-QAM Modulation Scheme

Figure 5 depicts the comparative plot of processing time plotted in bar chart against SNR. At $L = 3$ and 4-QAM modulation scheme, the values of P_t for EGC were 0.9 sec, 0.9 sec, 0.9 sec, 0.9 sec and 0.9 sec at SNR of 2, 4, 6, 8, and 10 respectively, while the values of P_t for MRC were 0.76 sec, 0.76 sec, 0.76 sec, 0.76 sec and 0.76 sec. The Hybrid EGC/MRC show a better performance compared to EGC and MRC with P_t values of 0.45 sec, 0.45 sec, 0.45 sec, 0.45 sec and 0.45 sec at different SNR. The result shows that hybrid model produce lower processing time. Therefore, hybrid model can be deployed to mitigate the effect of hardware complexity in the system.

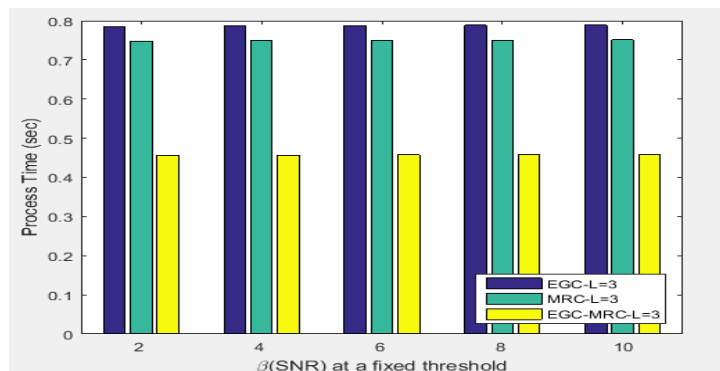

Figure 5: Plot of Processing Time against SNR for EGC, MRC and hybrid EGC/MRC at L=3 and 4-QAM Modulation Scheme

Figure 6 presents the plot of P_{out} values against different SNR. At $L = 2$ and 8-QAM modulation scheme, the P_{out} values for EGC were 0.35 dB, 0.19 dB, 0.13 dB, 0.10 dB and 0.09 dB at SNR of 2, 4, 6, 8, and 10 respectively, while the corresponding values of P_{out} for MRC were 0.22 dB, 0.10 dB, 0.07 dB, 0.05 dB and 0.04 dB. The hybrid EGC-MRC gave a better performance compared to EGC and MRC with P_{out} values of 0.07 dB, 0.02 dB, 0.009 dB, 0.006 dB and 0.004 dB at different SNR

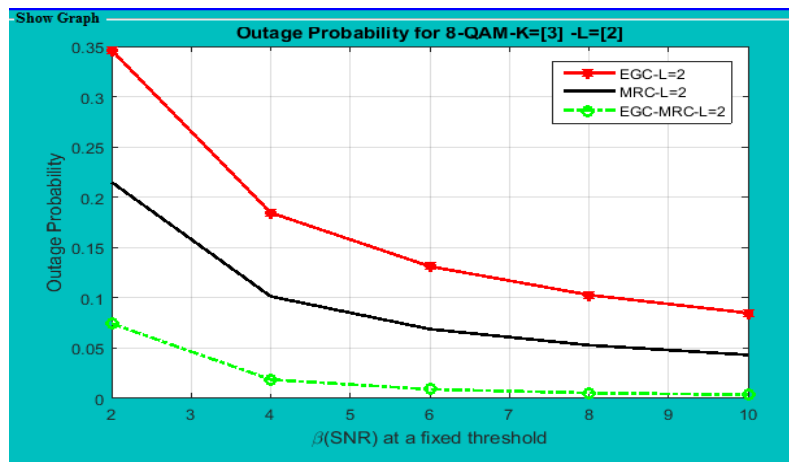

Figure 6: Outage Probability against SNR for EGC, MRC and hybrid EGC/MRC at L=2 and 8-QAM Modulation Scheme

Figure 7 shows the comparative plot of processing time plotted against SNR. At $L = 2$ and 8-QAM modulation scheme, the P_t values for EGC were 1.02 sec, 1.02 sec, 1.02 sec, 1.02 sec and 1.02 sec at SNR of 2, 4, 6, 8, and 10 respectively, while P_t values for MRC were 0.73 sec, 0.73 sec, 0.73 sec, 0.73 sec and 0.73 sec. The hybrid EGC-MRC gave a better performance compared to EGC and MRC with P_t values of 0.64 sec, 0.64 sec, 0.65 sec, 0.64 sec and 0.64 sec at different SNR. The developed hybrid model gave better results in terms of outage probability and processing time.

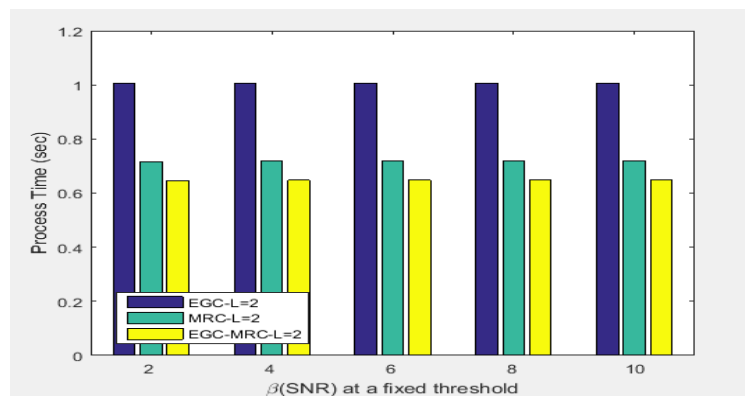

Figure 7: Plot of Processing Time against SNR for EGC, MRC and hybrid EGC/MRC at L=2 and 8-QAM Modulation Scheme

Figure 8 depicts the plot of outage probably values against different SNR. At $L = 3$ and 8-QAM modulation scheme, the P_{out} values for EGC were 0.35 dB, 0.14 dB, 0.08 dB, 0.06 dB and 0.04 dB at SNR of 2, 4, 6, 8, and 10 respectively, while the values of P_{out} for MRC were 0.17 dB, 0.07 dB, 0.04 dB, 0.03 dB and 0.02 dB. The hybrid EGC/MRC gave a better result compared to EGC and MRC with P_{out} values of 0.06 dB, 0.009 dB, 0.003 dB, 0.002 dB and 0.001 dB at SNR of 2, 4, 6, 8, and 10 respectively.

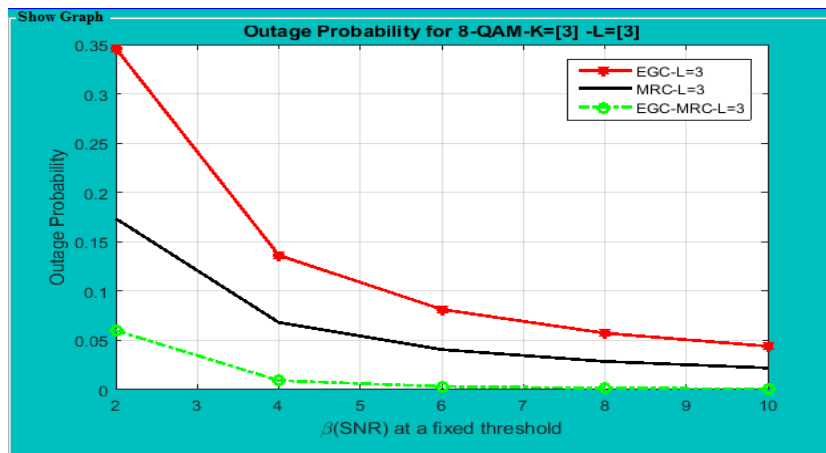

Figure 8: Outage Probability against SNR for EGC, MRC and hybrid EGC/MRC at L=3 and 8-QAM Modulation Scheme

Figure 9 depicts comparative plot of processing time plotted against SNR. At $L = 3$ and 8-QAM modulation scheme, the values of P_t for EGC were 0.95 sec, 0.95 sec, 0.95 sec, 0.95 sec and 0.95 sec at SNR of 2, 4, 6, 8, and 10 respectively, while the corresponding values of P_t for MRC were 0.81 sec, 0.81 sec, 0.81 sec, 0.81 sec and 0.81 sec. The hybrid EGC-MRC gave better result compared to EGC and MRC with P_t values of 0.75 sec, 0.75 sec, 0.75 sec, 0.75 sec and 0.75 sec at different SNR.

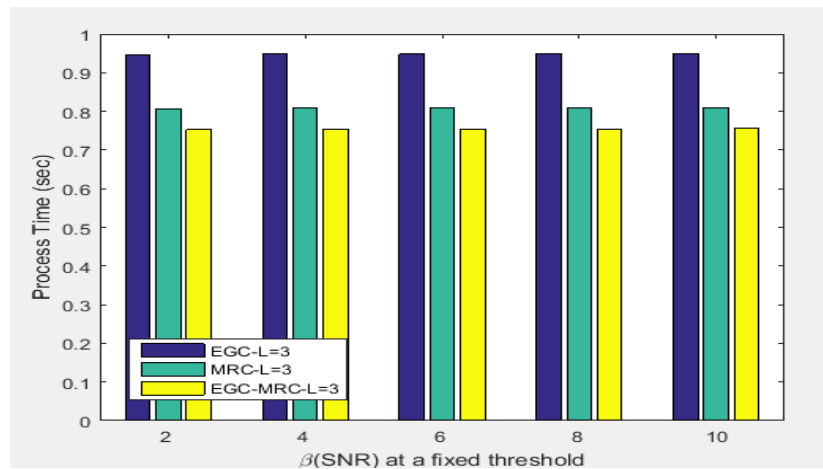

Figure 9: Plot of Outage Probability against SNR for EGC, MRC and hybrid EGC/MRC at L=3 and 8-QAM Modulation Scheme

Figure 10 presents the comparative plot of the total outage probably values against SNR. At $L = 2, 3$ and 4-QAM, the $P_{out}(dB)$ values for EGC is realized as 0.85 dB at L=2 and 0.67 dB at L=3, while the corresponding values of $P_{out}(dB)$ for MRC as 0.48 dB and 0.33 dB. Also, the result of hybrid EGC-MRC are obtained as 0.11 dB and 0.08 dB at L=2 and L=3, respectively.

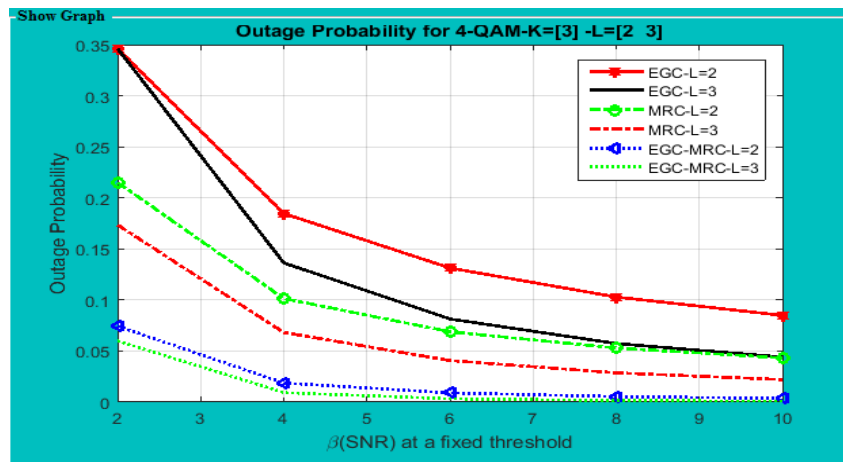

Figure 10: Outage Probability versus SNR for EGC, MRC and hybrid EGC-MRC at L= 2, 3 and 4-QAM Modulation Scheme

Figure 11 represents the bar chart plot for the processing time (P_t) against the SNR. The $P_t(sec)$ values for EGC were evaluated as 5.07sec at L=2 and 5.09sec at L= 3, while the correspondent values of MRC were 4.73sec and 4.75sec respectively. The $P_t(sec)$ values for hybrid EGC-MRC was realized as 3.53sec and 3.55 sec. The hybrid model showed a better performance in terms of reduced outage probability and processing time compared to the standalone models.

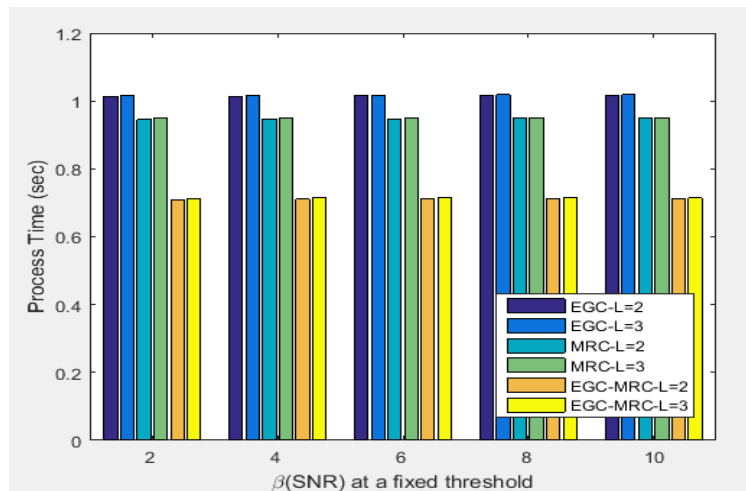

Fig. 11: Processing Time versus SNR for EGC, MRC and hybrid EGC-MRC at L= 2, 3 and 4-QAM Modulation Scheme

Figure 12 presents the comparative plot of the output probability values against SNR. At $L = 2, 3$; and 8-QAM modulation scheme, the $P_{out} (dB)$ values obtained for EGC at $L = 2$ and $L = 3$ were 0.85 dB and 0.67 dB respectively, while the corresponding values of $P_{out} (dB)$ for MRC at $L = 2$ and $L = 3$ were 0.48 dB and 0.33 dB. The hybrid EGC/MRC $P_{out} (dB)$ values were realized as 0.11 dB and 0.08 dB, respectively.

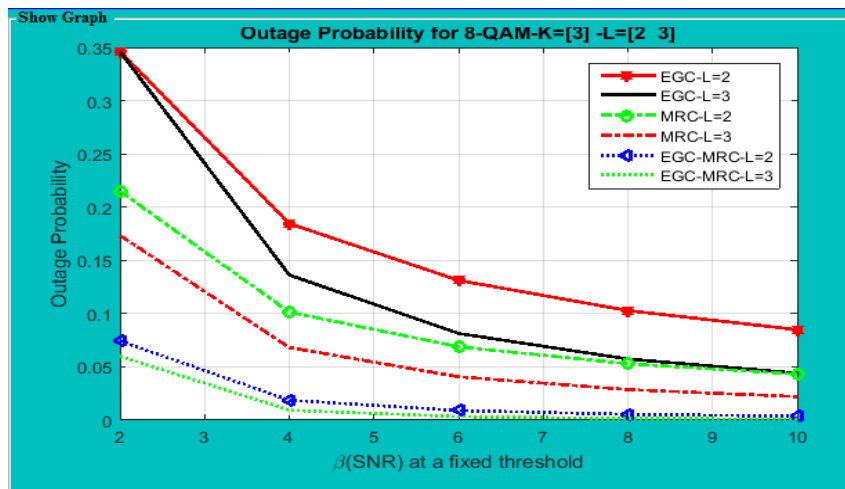

Figure 12: Outage Probability against SNR for EGC, MRC and hybrid EGC-MRC at L= 2, 3 and 8-QAM Modulation Scheme

The $P_t(sec)$ values as shown in Fig 13 for EGC when $L = 2$ and $L = 3$ were gotten as 5.12 sec and 5.1 sec respectively, while the corresponding values of $P_t(sec)$ for MRC when $L = 2$ and $L = 3$ are obtained as 4.54 sec and 4.50 sec. The hybrid system for the $P_t(sec)$ values were realized as 3.11 sec and 3.12 sec, respectively. The hybrid model demonstrated an enhanced performance with reduced outage probability and processing time relative to the increase in the number of paths and SNR. The study clearly proved that the hybrid model is suitable to mitigate the problems associated with multipath propagation in the communication system owing to its reduced system outage probability and processing time.

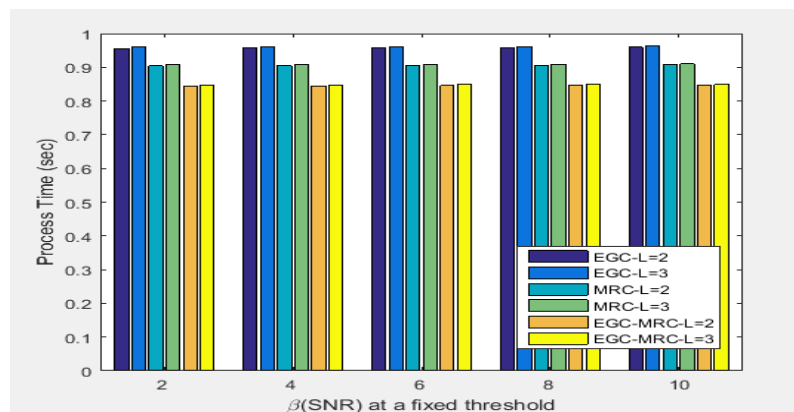

Figure 13: Processing Time versus SNR for EGC, MRC and hybrid EGC-MRC at L= 2, 3 and 8-QAM Modulation Scheme

9. CONCLUSION

The hybrid EGC-MRC diversity scheme was successfully developed with the simulation procedures carried out using appropriate network parameters over Nakagami fading channel. The output of EGC was applied as the input signal of MRC diversity combiner. The improved robust output signal from the EGC-MRC was passed through a single Radio Frequency (RF) chain and single Match filter (MF). The mathematical expressions for PDF of the output signal was developed for the hybrid model. This was used to obtain P_{out} expression for the hybrid model.

The P_{out} and P_t values for EGC, MRC, and hybrid EGC-MRC were obtained using designated SNR values. MATLAB R2015b was used for the simulation analysis. The performance of the hybrid system was realized using the following values; when $L=2$ and $L=3$, for 4-QAM and 8-QAM modulation schemes. The 8-QAM modulation scheme shows better result in terms of P_{out} and P_t compared to 4-QAM modulation scheme. The results showed that the developed hybrid model performed better than the EGC and MRC combiners with lower values on the output probability and processing time. This reduced values of the processing time attribute to reduction in the number of filters and RF chain. The new model also gave reduced outage probability (P_{out}) and processing time (P_t) as number of paths increases from $L=2$ to $L=3$ is an added advantage compared to the existing MRC and EGC models. The developed model is applicable in mobile wireless communication networks. The hybrid scheme is very suitable to mitigate the multipath propagation effects, reduced hardware complexity and cost compared to the existing scheme.

REFERENCES

- [1] Akande, A. O, Semire, F. A, and Adeyemo, Z. K (2017). "Analysis and Optimization of COST-231-Hata Model for Mobile Radio System in Nigeria". *Inter. Journal of Computer Applications*, vol.173, no. 6, pp. 4 -10.
- [2] Dinamani, A, Shruti, R, Babina, S and Das S (2013). "Performance Evaluation of a hybrid MRC-SC diversity Combiner in Rayleigh Communication channel". *Circuits, Controls and Communications (CCUBE) IEEE 2013 Inter., Conference, India*, pp 1-4.
- [3] Sodhi, R and Khanna, R (2016). "Analysis of Hybrid Diversity Combining Technique over TWDP Fading Channel". *Indian Journal of Science and Technology*, vol. 9, no. 47, pp.1-6.
- [4] Patel M, Nirav P and Paliwal, A (2015). "Performance Analysis of Different Diversity Combining Techniques with MIMO Systems". *International Journal of Advanced Research in Electrical, Electronics and Instrumentation Engineering*, vol. 4, no. 12, pp.9411-9418.
- [5] Nivethika S. D, Sreeja B. S, Manikandan E and Radha, S (2018). "A stretchable Smart and Highly Efficient Radio Frequency Antenna on Low Cost Substrate". *Microwave and Optical Technology Letters*, vol. 60 no. 7, pp. 1798-1803.
- [6] Kanthimathi M, Amutha R and Anusha, S (2018). "Modulation Diversity for Differential Amplitude and Phase Shift Keying Technique". *The International journal of Engineering Technology*, vol. 7, no. 1, pp. 418-420.
- [7] Sheikholeslami and Ashtiani (2015), "Optimal Probabilistic Initial and Target Channel Selection in Cognitive Radio Networks", *IEEE Trans., on Wireless Communications*, vol.14, no.1 pp 570 -584
- [8] Walia M and Mahindru A (2014). "Performance Analysis of Conventional Diversity Combining Schemes in Rayleigh and Rician Fading Channels". *IOSR Journal of Computer Engineering (IOSR-JCE)*, vol. 16, no. 3, pp. 28-32.
- [9] Singla M and Tiwana S. S (2017). "A Review on Hybrid Diversity Techniques over various Fading Channels". *International Journal of Engineering Technology, Management and Applied Sciences*, vol. 5, no. 4, pp. 118-120.
- [10] Simon M.K. and Alouini M.S (2015). *Digital Communications over fading channels*, New York, John Wiley and Sons.
- [11] Hoyong L, Sang K. P and Song, Y (2011). "Performance analysis of a hybrid SC/MRC diversity scheme over Rayleigh fading". *Proceeding of 13th International Conference on Advanced Communication Technology (ICACT)*, Korea, 2011, pp. 1115-1118.
- [12] Narayanan, S, Renzo, M. Graziosi, F and Haas, H (2016). "Distributed spatial modulation: A Cooperative Diversity Protocol for Half-Duplex Relay-Aided Wireless Networks", *IEEE Transactions on Vehicular Technology*, vol. 65, pp. 2947- 2964.
- [13] Sharma, P and Buttar, A. S (2014). "BER Improvement in Rayleigh Fading SIMO Channel Using Hybrid Diversity Combining Technique". *International Journal on Recent and Innovation Trends in Computing and Communication*, 2(8), 2355-2358.
- [14] Sayed, R, Shobug, M and Badrudduza, A (2016). "Performance Analysis of Diversity Combining Techniques over Rayleigh Fading SIMO Multicasting Wireless Network". *Scholars Journal of Engineering and Technology (SJET)*, vol. 4, no. 10, pp. 489-499.
- [15] Goldsmith A (2005). "Wireless Communications". New York: Cambridge University Press, USA.

- [16] Rajkumar S, Srinivasan N and Natesan, A (2018). "A Penta-band Hybrid Fractal MIMO Antenna for ISM Applications". *International Journal of RF and Microwave Computer-Aided Engineering*, vol. 28, no. 2, pp. 1-13.
- [17] Rao, P.H, Sujitha, R and Selvan, K. T (2017). "A Multiband, Multi-polarization Shared Aperture Antenna: Design and Evaluation". *IEEE Antennas and Propagation Magazine*, 59(4), 26-37.

AUTHORS

Akinyinka Olukunle Akande obtained his B. Tech (2008) in Electronic and Electrical Engineering from Ladoko Akintola University of Technology Ogbomosho in 2008. M.Eng in Communication Engineering in 2013 and a PhD in Communication Engineering in 2019 from University of Ilorin and LAUTECH, Ogbomosho, respectively. He is presently a Lecturer II at Federal University of Technology Owerri. His research interests include Mobile Wireless Communications and Resource Management in Cognitive Radio networks. He is a member of the Nigerian Society of Engineers (NSE) and Council for the Regulation of Engineering in Nigeria (COREN)



Onyebuchi Chikezie Nosiri acquired Bachelor of Engineering (B.Eng) Degree in Electrical and Electronic Engineering from Nnamdi Azikiwe University, Awka in 2002, Master of Engineering in Electronic and Communication Engineering and PhD in Communication Engineering from Nnamdi Azikiwe University, Awka in 2009 and 2015 respectively. He is currently a Senior Lecturer at Federal University of Technology Owerri. His research interests include developing modern adaptive noise/interference cancellation techniques for wireless networks, Cognitive Radio and Wireless sensor networks, forensic and data analysis for criminal community detection in wireless networks. He is a member of the Nigerian Society of Engineers (NSE), Council for the Regulation of Engineering in Nigeria (COREN) and Institute of Electrical and Electronic Engineering (IEEE).



Emmanuel Uchenna Ekwueme is an Assistant Lecturer at Federal University of Technology Owerri. He obtained his Bachelor and Master degrees in Communication Engineering in 2011 and 2018 respectively. His research interests include wireless communication system, 5G Networks, Software Define Networks and Machine Learning. He is a member of the Nigerian Society of Engineers (NSE) and Council for the Regulation of Engineering in Nigeria (COREN)



Nnaemeka Chiemezie Onuekwusi is a lecturer I, at the Department of Electrical and Electronic Engineering of the Federal University of Technology Owerri, Imo State, Nigeria. From the same institution, he received his Bachelor's Degree in Electrical and Electronic Engineering in 2007, Masters in Communication Engineering in 2012 and a PhD in Communication Engineering in 2019. He is a member of the Nigerian Society of Engineers (NSE), Council for the Regulation of Engineering in Nigeria (COREN) and Institute of Electrical and Electronic Engineering (IEEE). His research interests are in Wireless Sensor Networks and Smart Grids and has to his credit published works in the areas.

