

A Survey of the Non-Optimization techniques used in an integrated steel plant

Sankarshan Basu*

Goutam Dutta**

Abstract

This is a survey paper looking at the various different applications of the non-Optimization techniques in Operations Research techniques used in the steel industry particularly in the process of steel making all across the world. The paper is divided in to applications under the heads of Queuing Theory, Simulation, Statistical Process Control, Artificial Intelligence and Other Non-Optimizing methods. The survey covers a large number of papers across steel making facilities, all across the world, and it is seen that different locations have different types of applications of the various techniques mentioned above. In each of the papers mentioned above, we look at the applications of the topics mentioned and end the session with a critical review of the applications in that area. We conclude the paper with a brief list of topics that could serve as a future research base.

INTRODUCTION

An integrated steel plant is a complex industrial system encompassing a variety of inter-dependent activities, each activity being crucial to the smooth running of the plant and the production of steel in an efficient manner. It is a multi-product, multi-stage, multi-facility system in which different products are routed through different production units. The steel industry is an approximately 60 billion US Dollars (the annual US production is about 100 million metric tonne) industry in the USA alone; worldwide it is estimated to be around approximately a 400 billion US Dollars (the annual estimated world production being around 800 million metric tonne) industry. In this paper, we present a summary of operations research applications of the following methods in integrated steel plants.

**Assistant Professor, Indian Institute of Management, Bangalore, Bannerghatta Road, Bangalore 560 076. : sankarshanb@iimb.ernet.in - Corresponding Author*

***Professor, Indian Institute of Management, Ahmedabad. : goutam@iimahd.ernet.in*

Management Dynamics, Volume 6, Number 1 (2006)

1. Queuing Theory
2. Simulation
3. Statistical Process Control
4. Artificial Intelligence
5. Other Non-optimizing Methods.

Applications in the major steel producing countries of Asia, Europe, North America and Australia have been reported from 1965 onwards. Prior to our current paper, there have been six surveys. Mihailor (1961), which looks at 34 papers, is an elementary aid for engineers and metallurgists. This survey also gives an overview of how linear programming models can be applied in steel plants. Gercuk (1961) carried out a non-mathematical survey devoted to linear programming and some of its applications, mainly in the problems of composition charges, optimal loading of equipment and transportation of equipment. Thorsen and Vidal (1989) have looked at the theory and methodology of operational research in the Danish steel industry. They report the various planning, production and control problems faced by the steel industry in Denmark. They make an interesting observation; according to them there is a limit to the number of changes that can be controlled at the same time and hence, they suggest a gradual change to solve the problems rather than an abrupt and total change.

Another study by Rao et al., (1993), is a fairly comprehensive survey dealing with applications of operational research in the steel industry and it looks at 59 papers in which applications have been reported. Shah and Tripathy (1993) have edited a book on the various applications of operational research in the Indian steel industry. The book contains 17 papers, a number of which are specifically related to Simulation applications in the Indian steel industry.

Dutta and Fourer (1996) have looked at the various applications of Optimization techniques used in the steel industry. In this paper, we look at all those applications that have not been covered by Dutta and Fourer. An elementary knowledge of integrated steel making operation, though

Management Dynamics, Volume 6, Number 1 (2006)

desirable, is not essential. Those interested in more detailed knowledge of iron and steel production are referred to Lankford et al., (1985).

We hope that this paper will be of use to decision-makers in management. For them, this is hoped to provide possible areas of application of OR techniques in the integrated steel plant. The other group of people who we expect should be broadly interested in this paper are academics who are on the lookout for new and challenging areas of research in the integrated steel plant.

In this paper, we have tried to look at and present most of the applications in an integrated steel plant. However, we do not claim that this is an exhaustive and comprehensive survey covering all the operational aspects of an integrated steel plant. Though a lot of work in the field of OR is carried out in practically all integrated steel plants, a number of these studies and their results are never published, and hence cannot be easily accessed. We consider all the operations of steel making; from iron making to finished steel making, but we have not dealt with applications to the quarries and mines. The thrust in this paper has been more on real world applications or possibilities of such applications, and implementation of the models.

We start the survey with a brief description of an integrated steel plant in the second section. That section gives an overview of an integrated steel plant and also explains the specific terminology used. Section 3 looks at the various applications of Queuing Theory and Queuing Models that occur in an integrated steel plant. Section 4 looks at Simulation related applications in an integrated steel plant. In section 5, we discuss the various application areas and actual applications of Statistical Process Control in the integrated steel plant. In section 6, the use of Artificial Intelligence in all areas of the integrated steel plant is discussed. Section 7 deals with the use of other Non-Optimization Methods. Finally, we conclude in Section 8 with a discussion on the scope for future research. We also include a glossary of all terms that are specific to the Iron and Steel Industry that may have been used in the course of this paper.

AN OVERVIEW OF AN INTEGRATED STEEL PLANT

The material flow diagram of an integrated steel plant is enclosed. There are differences in the technologies used in steel making in the developed and developing economies. In the developed world (figure 1 Appendix), scrap is used in Electrical Arc Furnaces to produce liquid steel. The liquid steel is then allowed to pass through a continuous caster, which produces slabs and billets (depending on whether it is billet caster or slab caster). The slab or billet so produced is then reheated in a reheating furnace. The slab caster is required if the final product is sheets or plates or structural. Billet caster is required if the final product is a wire rod.

In the developing countries, the conventional blast furnace open hearth or BOF (basic oxygen furnace) process is used. Although the blast furnace technology is becoming obsolete, a large number of companies in the USA are still using the blast furnace technology. In many developing countries, because of the high cost of energy, the electric arc furnace technology can not be used economically and conventional blast furnace technology is used. In these conventional technologies, there is a coke oven, which produces the coke, and a sinter plant, which produces substitute of raw materials. The coke sinter and iron ore is used in the blast furnaces and the output of the blast furnace is hot metal. The hot metal is processed in a BOF to produce liquid steel. The liquid steel is then passed through continuous casters and the process is similar to that described in the last paragraph; that is the method is similar to the one when electric arc furnaces are used.

In South Korea, DCHR (Direct Charged Hot Rolling), method is used. In this case the output from a continuous caster is used directly (without reheating) for final rolling of the product.

QUEUING THEORY APPLICATIONS

Stochastic control of the manufacturing system is one of the most important research areas in the nineties. Queues are inherent in all multi-stage-manufacturing systems. In the case of steel companies, it is reported

in the literature that queues mainly occur in the primary mills and the finishing mills. Some queuing problems have also been reported from the Basic Oxygen Process and the Continuous Caster stage. Queuing models have also been used to perform capacity calculations for various sections of a steel plant.

White (1985) in his paper gives a fairly comprehensive guide to the real world applications of the Markov decision processes, of which two applications specifically refer to the steel industry. The first one, which had been reported by Fabian et al. (1959), deals with the amount of raw material to be purchased to meet demands in light of fluctuating prices. The states considered here are the stock levels and the prices. As a matter of fact, this model has actually been implemented. The second application he refers to is one that has been dealt with extensively by Buzacott and Callahan (1971; 1973), the problem of effective utilization of soaking pits. This study by Buzacott and Callahan, though much simplified, acted as a guide to further simulations on the basis of which actual decisions were made.

Carmichael (1987) has discussed the applications of queuing models in the optimal loading policies for pusher-scrappers as well as the capacity calculations in the mining industry. The same set up prevails in an integrated steel plant and thus, can be easily generalised to the case of application in an integrated steel plant. He has discussed queuing models, which include allowances for the variabilities in the pusher-scraper cycles, as well as for the interaction among the scrapers.

Sugawara and Takahashi (1965) have discussed some typical queues that occur in an integrated steel plant. They look at the problems of material flow from one point to the other in an integrated steel plant like Yawata, Japan. In particular, they look at the problem of material flow to the soaking pits of the primary rolling mills from the steel-making furnace. Due to irregular flow of materials, at times a lot of material comes in and thus has to be kept waiting before it can be soaked. This results in cooling of the hot steel ingots. Thus before soaking the cold ingots have to be either taken out of the queue or reheated before further forward movement.

This results in either loss of materials or increased cost on account of reheating. In their paper, they discuss under what conditions the waiting lines grow infinitely large. They conclude by saying that if the facilities and equipment of steel plants and primary rolling mills are arranged in a direct line (as has been done in the newer plant at Tobata of the Yawata Iron and Steel Company Limited, Japan), then this problem is greatly reduced.

A problem that has been observed by the second author of this paper in practice in an Indian steel company, while he was employed by that company, is that the causes of queues were not always mechanical or system faults. In fact, attempts to model these queues using the standard statistical distributions were not successful. At many places the cause of the queue was lack of action by the operators; refusing to work at certain times. Thus, the arrival pattern of material is also dependent on the psychological profile of the workers in the steel melting shop. Such a phenomenon is extremely difficult to model mathematically. The problems were found to be more manifest during night time operations and when production pressure was high. It was also observed that there was more tapping of "heats" at the end of the shift rather than at the other times of the shift. He had suggested that there be more controls and checks in the production line to ensure such man-made delays do not occur as they lead to a lot of profligate expenditure for the company. Interesting work on similar lines has been done by Katz et al., (1991). They have looked at the problem from a general set up, not from the steel industry specific point of view. They have considered each of the customers in the queue to be human beings. In the steel industry case each customer would be an ingot in the soaking pit representing a psychological profile of the operator behaviour in the steel melting shop. But it can be easily seen that the observations can be extended to the situation in the steel industry. They have discussed the psychological problem of the workers in any situation where queues form based on the qualitative observations on a queue.

Woodall et al., (1970) discussed the development of mathematical models of section-making facilities within the Iron and Steel Division of the Bethlehem
Management Dynamics, Volume 6, Number 1 (2006)

Steel Corporation, Northern Tubes Group. They investigated potential savings with reference to the use of the productive capacity of the section. The model was so developed that it reproduced mathematically all the essential production processes involved in the manufacture of structural section sizes, allocating sizes to the mills so as to minimize production costs. They used the model to reproduce the required quantities based on production and cost data. Further, they also explained in detail the other possible uses of the cost and production data including evaluation of planning decisions indicating where capital expenditure would be beneficial.

Ashour and Bindingnavle (1972) have outlined an optimal design for the soaking pit rolling mill system of an integrated steel plant. This work was done to analyse the flow of materials through the nonproductive units (the mixer and soaking pits) of a steel plant. They point out that these two units could seriously hamper the production capacity of the plant by causing serious bottlenecks if their capacities were not determined before installation. They consider the soaking pit/rolling mill complex as a queuing system in which the soaking pits are viewed as units circulating a cyclic queue and the rolling mill as the service station. They developed a simulation model to represent the pit-mill system. The model was required to predict the improvement in capacity of the system through adding more pits, and to predict the effect of breakdowns and maintenance or shutdown of a pit. They conclude their work by saying that even a small reduction in mill idle time will offset substantial costs for pits and increased capacity until the optimum is achieved. In this context, it would be profitable to undertake preventive maintenance of cranes whenever the mill is idled for change of rolls.

Critical Review

Queuing Theory requires a lot of sophisticated and complicated mathematics. The lack of appreciation of sophisticated mathematics by the ordinary shop level operator results in less importance being attached to these types of studies and their applications. We find that very few applications have actually been implemented or tested with real data in an

integrated steel plant. As the applications are minimal there are hardly any reported financial benefits. The psychology of queuing systems is an important feature in the proper functioning of an integrated steel plant. Most manufacturing problems for capacity calculations are found to be stochastic in nature; but no major work has been reported in this area.

SIMULATION APPLICATIONS

Simulation is a very important part of any scientific application and the steel industry is no different, especially when the cost of setting up a plant or even altering an existing plant set-up is so large and time consuming. Thus, simulation techniques have to be employed to ensure the correct and desired output before the existing system is changed or a new system is installed. Simulation in the steel industry has led to a reduction in the cost of installation or upgradation. Simulation in the steel industry could be broadly classified into five areas, which are not however, always mutually exclusive. They are:

System Dynamics Simulation

Sinha and Dutta (1985) looked at a system dynamics model of the blast furnace for project evaluation purposes. They identified the major interdependencies forming a feedback structure, which lead to a system dynamics model of the blast furnace. The model has been used to evaluate projects on an overall and long-range basis. The model has been used at an Indian steel company for the evaluation of projects like the reduction of coke ash from 26% to 23 % and even less, increase in blast furnace temperature to 1100 oC and a new sinter plant increasing the availability of sinter.

Narchal (1988) has dealt with the problem of having a simulation model for helping in Corporate Planning in an Integrated Steel plant. He based his simulation model on system dynamics principles, initiated by Forrester (1964) at the Massachusetts Institute of Technology, USA. The model has been designed to ensure that material flow takes place through

a group of twelve production units arranged in six stages of production. Functioning of the model requires a time variant input demand of seventeen categories of finished steel products and three categories of raw materials. The model is being used by management for simulating the impact of their strategic policy on corporate objectives. The model also helps the management in designing their long-term investment policy related to expansion and modernization and for the smooth flow of production.

Dangerfield (1993) presented a system dynamics model which showed that, for a typical integrated steel works, the market response to lack of steel availability can more than offset any economies of scale in production costs. In addition, larger units with higher fixed costs are financially less able to withstand cyclical downturns in demand. As a result, works employing smaller blast furnaces may be more profitable than those containing larger furnaces.

Process Modelling and Simulation

Mellor and Tocher (1963) have described the development of a continuous control system of a steel works to ensure that the idle time of steel mills is minimum and that orders are met. A computer simulation is the basis of the game (using the General Simulation Programme) which was run in conjunction with human controllers.

Anandalingam and Bhattacharya (1985) have made use of a process model to study industrial energy use in the developing countries with specific reference to the steel industry in India. They have modelled production by a set of inter-connected process activities, each of which defines unique relationships between process output and number of inputs. Unlike the process models used in the USA, the authors here have not assumed cost minimizing behaviour. They then perform a large number of simulations and come up with the conclusion that though a number of cost-effective energy conservation measures exist, none of them leads to significant reductions in energy use. However, on combination of the strategies, significant reduction in energy takes place.

Lin et al., (1989) discussed hierarchical production planning in an integrated steel plant. With their methodology and starting from the demand data, a detailed production schedule providing for continuous operations in an integrated steel plant can be derived. The production schedule will satisfy the customer's orders as well as other desired objectives at the lowest possible energy cost. The results from their model showed that such an integrated scheduled system could substantially reduce the amount of energy required in the systems presently in use. The model also provides a smoother, more flexible as well as more prompt supply to the customers.

Discrete Event Simulation

Uchiyama and Sugahara (1962) applied Monte Carlo methods to determine optimal capacity of ingot reheating furnaces at the Yawata Iron and Steel Company, Japan. The ingot arrivals to these furnaces are multiple Poisson distributions, and the ingot reheating times depend on the waiting time to put the ingots into a furnace.

Bruno (1971) discussed applications of a foundry producing centrifugal pipes with the following objectives: Optimizing the size of melting plants and working of Cast Iron; Checking and Optimizing the operating cycles for various plants and processes; Cost reduction of loading and transformations; and Productivity improvement of the plant installation.

Montaldo (1972) discussed an ingot mold foundry simulation model that was given as a tool to the foundry managers. The input variables were quality and arrival rates of hot metal. The output variables were ingot mold mix and its sequence. Production cycles and some results were also discussed.

Maity and Jain (1993) have looked at the problem of an effective coal blending system under the conditions of a variable receipt system. Previous experience had shown that improper blending of coal resulted from plant operators being forced to hold wagons in an effort to correct deviations in arrival pattern, resulting in high demurrage without any appreciable improvement in the blend. In their paper, the authors framed

decision rules which would enable blending and bedding decisions to be taken based on the forecast (the forecast being based on the principle of Moving Averages) of the arrival pattern of various components of coal. These decision rules were tried out by simulation with actual operational and arrival data. It was found that while the blending achieved only a slight improvement as a result of these decision rules vis-à-vis the actually achieved data, wagon detention decreased quite significantly. An interesting conclusion of this study is the fact that any policy that does not take into account the arrival pattern of coal will result in higher detention of wagons while failing to achieve the blending objectives.

Khanna (1993) developed a computer based simulation model for the transportation of the slag produced in a blast furnace in an integrated steel plant. He has carried out a large number of computer simulation experiments, to determine the optimum number of locomotives and slag ladles in the system, at different stages of expansion of Slag Granulation Plant. He also observed that the results from the experiments compared favourably with the results from the actual operating system, which meant that the simulation model provided a realistic approximation of the physical system. However, there is scope for further improvement in the efficiency of the model by incorporating some exogenous variables, like ladle filling time and ladle placement time for top and bottom slag, which have otherwise been taken as a constant.

Ganguly (1993) has studied the LD Converter - Continuous Casting System at the Bhilai Steel plant, India, and has modelled the casting system as a queuing model. He treats the "Heats" produced by the converters as the "customers" which must wait at the continuous casting bay (concasts) to be served. The performance of this system is measured in terms of number of heats produced, concast and converter utilization, number of reheats, and number of concast shutdowns due to heat delay.

Sastry et al., (1993), sought to look at improvements in the ingot to slab yield percent by the use of simulation techniques. They observed that

by ensuring that slab thickness is controlled based on the results of the study, the overall yield of ingots can be increased by about 1% irrespective of the quality of steel rolled.

Kalro et al., (1993) have looked at the dispatch planning schedule of finished steel in an integrated steel plant. They explored two major problems. First, they tried to evaluate various dispatching parameters at the control of the steel plant. This was to study the implications on finished goods inventory and percentage piecemeal wagon requirements, and it was done through a simulation model. Their second objective was to develop a decision support system for day to day operational planning of dispatches through a data base management/spreadsheet model.

Visual Simulation

Kiuchi and Yanagimoto (1990) outlined an advanced computer aided simulation technique for three-dimensional rolling processes. They first carried out the mathematical formulation of the extended complex element method (CEM) and then applied it to the universal rolling processes of H-beams. They found that the results on rolling load and other factors, as well as the geometry of the rolled product were reasonable and acceptable. They conclude by saying that the extended CEM can become an effective tool for the design and diagnosis of roll profiles and pass-schedules. They also state that simulation is a much more economical and convenient method than the ordinarily available methods.

Physical Simulation

Ferguson (1988) describes the physical simulation of a Continuous Steel Process. He pointed out that the value of physical simulation is often difficult to determine and thus remains unrecognised. However, in the case of continuous casting simulations, the savings resulting from optimizing the process to reduce slab cracking can be in millions of dollars per year. Optimizing a continuous caster using the actual production mill would be 100 to 10,000 times as costly as physical simulation in the laboratory.

According to Ferguson, with the ever changing demands on materials and the processes that produce them, computerized physical simulators are fast becoming an economical necessity of modern mill operations.

Peaslee (1996) sought to analyse the physical modelling of slag splashing in the Basic Oxygen Furnace (BOF). He states that research has shown that slag splashing increases with larger lance angles and larger lance heights. He outlined the experiments being conducted at the University of Missouri-Rolla for improving the efficiency of present slag splashing practices; for providing more consistent slag splashing inside the furnace; developing selective splashing when required; and designing more effective lances, specifically for slag splashing. He concluded by noting that the larger the lance angles and lance heights, the greater is the amount of splashing, assuming that all other jetting characteristics are constant. He also noted that it seems from the results of the experiments, which are still ongoing, that the mechanism of slab coating changes from one of primarily splashing, to additional washing, as the viscosity of the liquid increases.

Critical Review

Compared to the queuing model applications, some studies in simulation have actually been carried out with real data. Simulation models have been found to be very useful in the calculations of the capacities of the LD-CC process in India. The study found that the capacity of the CC machine was about 25% to 30% more than the design specified capacity. Box and Herbe (1988) at LTV Steel Company in the USA, carried out similar work with an optimization model. Most other applications including system dynamics simulation are reported mainly from India. These studies have used real world data and recommended improvements to the management. However, implementations of such recommendations have not been reported.

STATISTICAL PROCESS CONTROL APPLICATION

Statistical Process Control (SPC) is an integral part of the Quality Assurance set up of any industry and the steel industry is no exception. In

Management Dynamics, Volume 6, Number 1 (2006)

fact, it is more important in the steel industry than in some other industries. In the steel industry, process control is a very important operation because if one process is malfunctioning, all the other following processes will be producing defective materials. This is because, as has been described earlier in Section 2, the output of one process is the input to the next process in an integrated steel plant. As a result, to ensure a low rejection rate of finished product, ensuring the plant to be efficient and cost-effective, it has to be ensured that each and every process functions properly. It is to ensure these necessary random checks that statistical procedures are used.

Woodyatt (1990), discussed the evolution of a SPC based program followed in the Purchasing Department of Bethlehem Steel Plant for evaluating the Quality Assurance efforts of all its major suppliers of cast and forged rolls. The system has been implemented in 1986 and numerous benefits, both tangible and intangible, have accrued as a result. Some of the benefits were: All suppliers were required to have SPC based quality control programs which should ultimately lead to an improved roll performance and lower variability; An improved understanding of each supplier's manufacturing capabilities and limitations; More predictable deliveries; Improved roll performance; An improved uniformity of hardness within rolls and between rolls; and An improved dimensional uniformity within and between rolls.

Woodyatt and McNamara described the development, use, and functioning of a menu-driven SAS-based system at Bethlehem Steel's Sparrows Point Division to generate the product specification conformance reports required by many customers of tin-plated and cold-rolled steel products. The system, though initially developed for use by the Quality Control departments, also functions as a guide to quality control engineers to undertake any corrective actions which may be necessary to maximize product capability.

McNamara and Woodyatt presented the Rod Mill Billet Surface Quality Reporting System, which was developed for Bethlehem Steel's

Number 3 Rod Mill. The system was designed to provide a mechanism for tracking and reporting on the surface quality of rod mill billets to enable the management to ensure production of quality rod products. The system was developed in two years to satisfy the needs of the General Management, Quality Assurance and Operating Departments (both at the Bar, Rod and Wire Division); and the Sparrows Point Division. The need for such a system arose at this mill because the billets were sourced both from ingots and caster steel produced at a number of locations. The system was designed to monitor surface quality at all points (even during normal operation there are a large number of inspection points, surface preparation and rejection points), relate any quality problems back to their appropriate source, and compare quality of billets from different sources.

Woodyatt and Popp (1991) outlined the roll performance computations for strip mills at Bethlehem Steel Corporation's plants at Burns Harbor and Sparrows Point. However, the determination of Roll performance is a very complex task, though in the paper the data and the assumptions were relaxed greatly. However, in actual practice, it is necessary to account for other facts like : Position within the stand; Reasons for change; and Reasons for reconditioning. Alternatively, hardness and depth below original surface might also be factors to be looked into to check for the effect on the basic methodology. Finally, statistical tests like tests based on the "t statistic", requiring the mean and variance within each supplier's group, should be conducted to compare the performance of different types of rolls. Based on these results, performance of rolls of different suppliers can be easily compared.

Malu (1993) described the application of Taguchi's concept in manufacturing of products in a company receiving raw material from an integrated steel plant. In this work, the aim was to develop optimal process parameters to maximise mill yields that ensures specified production levels.

Harris and Yit (1994) have compared the successful and unsuccessful SPC project implementations at 12 integrated steel companies,

to determine the differences in the key factors. They observed that successful implementations had larger teams and more middle management support than unsuccessful implementations.

Roey, et al., (1996) described the development and application of models for the accurate profile and flatness control on a hot strip mill at Mannesmann Demag Sack, Ratingen, Germany. The hot strip model discussed here provided finishing mill set up and control, provided closer tolerances on target profile from coil head to tail, and improved flatness. In the development part, both theoretical as well as experimental methods were used in the model that integrates a variety of sub-models defining the effects of work and backup roll wear, thermal camber lateral deformation, creep and buckling. The model incorporates features such as work roll bending, work roll shifting and hydraulic gas positioning.

Everett (1996) made use of simulation techniques to show that process control activities on appropriate handling of the iron ore can greatly improve the quality of the finished product. The method showed quite a few clear benefits, one being the obvious cost benefits. The other advantage of his model is the graphical nature of the simulation model. The graphical nature makes it easily accessible and understandable to managers as well as operators. This enhances the understanding and acceptability of the model while also, facilitating both manager's and operator's contribution to the development and testing of the model for further refinement.

Critical Review

Although SPC techniques have been used in roll performance monitoring, no such applications have been reported for monitoring the consistency of the raw materials used in the iron making, and subsequently steel making processes. In developing countries like India, the composition of the raw materials fluctuates widely, which affects the quality of hot metal and subsequently the finished steel. For example, consistency of silicon and sulphur in the blast furnace hot metal is a prime requirement for high quality steel. Though SPC can play a significant role in this area, no

such work has been reported. Other applications, which have been reported, including those from the developed countries, are in the areas of rolling more so than in the finishing mills.

ARTIFICIAL INTELLIGENCE APPLICATIONS

Artificial Intelligence (AI) has been defined as the study of mental faculties through the use of computational methods. Although first introduced as early as 1956, it is only in recent years that AI has gradually earned recognition as a reliable new technology. Truly practical applications have been possible because of the major advances in information systems technology. One of the most promising developments to date has come from the steel industry, where the most popular application area has been in operator guidance for the complex primary end processes. As Argyrppoulos (1990) mentions, AI is expected to perform the following fundamental tasks: Knowledge representation, Search strategy, Heuristic, Deduction, Reasoning strategy and Planning. In this section, we describe applications in each of the stages of integrated steel making.

Iron Making Stage Applications

Otsuka et al., (1990) at the System Engineering Division and the Iron and Steel Research Laboratories at Sumitomo Metal Industries, Japan developed a Hybrid Expert System combined with Mathematical Models for Blast Furnace operations. The introduction of the system had certain advantages. The consistency of silicon percentage in hot metal and Hot Metal Temperature (HMT) are the two important process control variables. First, automatic control decreases the deviations of HMT and silicon content in hot metal more significantly than manual control by experienced workers. Secondly, through the precise judgement of furnace state, the target value of HMT can be controlled at different levels depending on furnace state. Accordingly, appropriate control of blast furnace operation is possible leading to minimum energy cost. Thirdly, in case of abnormal furnace state, a lot of emergency actions can be performed leading to fewer rejections. The system, with suitable improvements, could also be used for more

precise estimation of inner furnace state, and in the long term, policy making of the furnace operation.

Niwa et al., (1990) devised a self-learning function which was applied to an expert system for blast furnace heat control, to improve controllability of temperature and chemical composition of hot metal and to improve maintenance of the system at the Fukuyama Works, NKK Corporation, Japan. This system has been operational since March 1988. As a result of improving the maintenance of the system, the controllability of the furnace heat and the application ratio of BAISYS (the expert system used for control of blast furnace operation) have been kept at a very high level.

An expert system representing the empirical knowledge for normal operation control of the blast furnace was developed and practically applied to Blast Furnaces Numbers 3 and 4 at Kimitsu Works, Nippon Steel Corporation, Japan by Amano et al., (1990). The significant difference of this system from the others of its type is that in this system the field operators make programs and improve them without any help from the system engineers. The operational control system, called the ALIS (Artificial and Logical Intelligence System), contains about 700 rules, far more than conventional furnace operation control systems. However, for better performance of the system the improvement of the knowledge base is required. Further advances are also necessary in the areas of information acquisition, thinking and judgement, action, evaluation and learning; and processing speed.

Chen Jian (1993) proposed and applied an Expert System to predict the silicon content in the pig iron for a blast furnace. It combines an adaptive predictor with a knowledge base. The results of tests indicated that the predicting system is significantly more accurate than experienced operators or adaptive predictor alone; not only in stationary conditions but also under non-stationary conditions. It can also be used as an operator guide to help control a blast furnace.

Steel Making Stage Applications

Sasabe et al., (1990) discussed the application of Real Time Expert Systems to Mold Bath level control of a Continuous Caster at the Wakayama Steel Works of Sumitomo Metal Industries, Japan. This expert system can work in conjunction with conventional control systems and can infer at a very high-speed. The improved control system, other than performing the conventional functions, also incorporates other functions like optimization of control parameters, assessment of the cause of mold bath level fluctuations, and assessment of the operational state. This system was put to use, and it was observed that ratio of billet casting, whose level fluctuation was more than 5mm, was reduced to 60% of that using conventional control systems.

At the Steelmaking Technical Department and the Electrical Engineering and Process Automation Department of Sakai Works, Nippon Steel Corporation, Japan, an expert system prototype was developed by Kanemoto et al., (1990). The prototype was designed for the LD Converter Process to investigate the possibility of future advances in blowing control system. This system is successful in applying the expert system to on-line real-time process control and applying fuzzy logic reasoning to represent the ill-structured problem. As a test result, high blowing controllability, equal to that of a skilled operator was achieved to prove the application of knowledge engineering to blowing control. The test results have shown that the use of the expert system permits on-line real-time reasoning at a high speed leading to a substantial reduction in reasoning speed and a more accurate control of end-point composition and temperature. This system results in a stable operation of the LD process irrespective of the level of skill of the operator.

Rolling Mill Stage Applications

An expert system has been developed by Hirao et al., (1990) at the System Engineering Division and Kashima System Planning Department, Sumitomo Metal Industries, Japan. The expert system allows for the efficient

transfer of coils and is now in real time operation as a part of the finishing control system. The expert system has two main functions: selection of a coil to be transferred; and a point of loading or unloading of the coil to a coil car in a looped track. This expert system was successfully developed within 10 months, the prototype being developed within 6 months, and its test and modifications performed over the next 4 months. The finishing control system is estimated to contribute to the improvement of productivity and saving of manpower in the finishing line.

Also, at the System Engineering Division and the Kashima System Planning Department, Sumitomo Metal Industries, Japan, using an expert system building tool (SMI/Marks-II), a fully automatic assignment system of slabs for a hot strip mill was developed by Jimichi et al., (1990). Selection or assignment of stocked slabs for the product orders can be performed automatically. This expert system was compared with the conventional assignment method for a month by using the same data of slabs and orders. The average numbers of data used were 1500 pieces for slabs and 3000 for orders. The expert system selects about 200 matches, the remaining slabs are listed and reserved for the next assignment. It was observed that the number of assigned pairs was almost equal to that achieved by a human expert. Further, the assignment of slabs with excessive upper grades can be eliminated, and that the job time is reduced from 6 hours to 1 hour. The expert system can be easily maintained for environmental changes. The total elapsed time is 40 minutes (20 minutes for the primary selection process, 15 minutes for the assignment process and 5 minutes for the printing process). This system has been operated once a day as a regular batch job since August 1988.

Sasaka et al., (1990) at Nippon Steel Corporation, Japan developed a fully automated bar mill pacing control system incorporating Artificial Intelligence to determine and control automatically the material discharge pitch from the reheating furnace. The material discharge pitch is a dominating factor affecting productivity and operating efficiency. The fully automated discharge system was realized by developing an expert

system based on the most suitable inference of productivity in each process of steel bar flow. The production capacity of mill and finishing line is determined from a knowledge base. The expert system achieves on-line and real-time control. The introduction of the expert system at the Muroran Works led to the following production improvements: improvements in rolling tons per hour due to minimization of discharge pitch, and improvement in production efficiency by avoiding discharge interruption caused by line jam. Furthermore, it led to the reduction of the operator's load.

Vyas et al., (1990) have discussed the use of an expert system to recommend the roll adjustments for the 28-inch rail mill at Bethlehem Steel Company, USA. The expert system was developed and installed in the mill to recommend the “best” of several possible complex roll adjustments using real-time data input by mill operator. The expert system also includes supporting computer programs for rail dimension trend charting, data reporting, and statistical quality control charts. The system helps in standardizing the mill roll adjustment procedures and improves the quality of operator decisions. The automatic plotting of rail dimension trend charts and SPC charts compared to manual plotting saves time, provides greater assurance that rails meet required specifications, and results in productivity and yield improvements. The system is being enhanced to add rules dealing with the interaction of other process variables which affect the ways in which mill rolls are adjusted to further improve rail dimension uniformity.

Srivastava (1993) at Northwestern University has developed an “Intelligent Scheduler’s Assistant” (ISA) which is a prototype computerised manufacturing and scheduling system for the sheet mill of a steel plant. The ISA is based on the “History Inference Processor” which provides inference about the problem and the problem solver. The inferences are used for two primary purposes: to provide information to the ISA to help it to take action; and secondly to make inferences about the human problem-solver’s goals and priorities and thereby incorporating them in the solutions

developed. According to him, results of experiments have shown that the ISA demonstrates improvements in the effectiveness of the ISA in terms of meeting goals and efficiency of the system.

Nicklaus F. Portmann et al., (1995) have reported the use of Neural Networks in rolling mill automation. The specific example of such an application is in the area of pass-schedule calculation, which has been described in this paper. These combination models are now both in test and production operation at the Westfalen Plant of Krupp-Hoesch Stahl, AG, Dortmund, Germany. Test results have shown that neural networks can be valuable additions to the process control systems when applied properly and when their limitations are taken into account. This particular area is very dynamic and a lot of areas still remain open for further work. Presently, some of the other areas on which the authors are working are : Prediction of natural speed in the finishing mill; Prediction of strip thickness profile; Prediction of spread behaviour at the ends of its transfer bars, Distortion free on-line adoption; and Automatic strip classification by relation to deformation resistance.

Anabuki et al., (1996) at Kawasaki Steel Corporation, Japan have applied an Expert System to real-time transportation control in a complete operation of a new electrical steel finishing line, where no prior operation experts existed. It enabled a systematic analysis of the complex operation methods for a new plant, where no experts existed. Development took as many man-hours as would have been required for conventional programming and was commissioned in March 1990. However, in this set up a response time of less than 3 seconds was achieved.

Production Stage Independent Applications

Williams (1967) outlines the importance of use of computer techniques for planning and organization in an integrated steel plant. He lists the possible uses of computers in an integrated steel plant, ranging from process control to research, at the same time stressing the need for integrated computer development plans. He says that the computer should

be used as a man-machine partnership system and not in isolation. According to him, the main problem of implementation of effective computer systems has been the inaccuracy of the works recordings. He discusses, at length, the direct and indirect benefits to management as the information and control system evolves.

At the Electronics Research Laboratory, Kobe Steel, Japan an expert system shell was developed by Narazaki et al., (1990). The system uses a personal computer using C language for diagnosis problems, such as fault diagnosis and process operation guidance. Further, by using the tool, it is easy to build expert systems such as automatic process monitoring systems, automatic action guidance systems, and off-line interactive consultation systems that co-operatively work with the existing software. Therefore, the tool is appropriate to construct on-line expert systems.

Ogai et al., (1990) at the Electronics R&D Laboratories of Yawata works, Nippon Steel Corporation, Japan have developed an expert system for Quality Diagnosis of Glass Films on Silicon Steels. Artificial Intelligence software, human-machine interface software, and other necessary programs were developed and implemented on a 32-bit UNIX computer. This expert system has been used in commercial production since November 1988. The operating technology staff and operators at the silicon steel mill are daily refining the knowledge base and creating a knowledge base for a new grade of silicon steel. Also, the use of neural networks as a knowledge base learning system is under study and its practical applications is one of the future issues.

Lock Lee et al., (1990) at the BHP Central Research Laboratories, Australia have developed a facility called SHERPA (System for Heuristic Real-time Process Assistance). SHERPA enables prototypes of real-time applications to be developed over short periods, typically days or weeks. A decision table based on a knowledge acquisition tool, TABLEAUX, is used in tandem with SHERPA for the production of real-time expert system applications. The application of expert systems technology to real-time

applications has been very much hindered by the poor availability of suitable tools in the area. Those that have been developed are often delivered as closed systems (requiring specific hardware and software systems). As a development philosophy, prototyping expert systems in simulated environments as close to reality as possible, has been very useful. The ability to quickly build, test and refine real-time systems is going to play a large role in the rapid deployment of AI technologies into process control environments.

Critical Review

Most of the applications reported in this field are from Japan, although a few have also been reported from Germany, Australia and USA. AI has, unlike most of the other techniques, been found to be used in practically all operational areas of an integrated steel plant. Japanese steel makers have achieved some notable successes in applying AI techniques to steel making, blast furnace operation and maintenance. This is particularly true for condition monitoring and real time process control. The use of AI can be coupled up with SPC for ensuring improved quality and higher productivity. Although applications of other OR techniques have few reported quantifiable benefits, AI applications have resulted in substantial improvements in productivity and quality.

OTHER NON-OPTIMIZATION METHODS

Applications of OR techniques in areas other than those mentioned earlier have also been found to occur. In this section, we outline a few such applications.

Thomas (1963) discussed the work of OR departments in integrated steel plants in the United Kingdom. Particular importance was attached to mathematical, statistical and electronic computing. Mathieu (1962) presented an example in which diversely different contingencies, on one hand with steel making and on the other with cold rolling, were associated. Both contingencies were considered in seeking the maximum profitability.

Masobriò (1971) has discussed the problems faced in the introduction of operational research methods in the organization of a steel plant. He observed that the need for effective and rapid introduction of OR in the steel plant required an accurate selection and a complete training of the specialists. This should be coupled with education of the environment on the possibilities and limits of OR so as to develop a reasonable level of confidence towards these techniques. The OR activity dealt with, aside from the traditional problems, the two additional problems of the information system of the plant and process control. In conclusion, he observed that the methods of OR lead to substantial benefits if they are performed in a sufficiently advanced managerial context.

Rosegger (1980) examined the physical and economic performance of major innovations in steel making. He compared the then modern Basic Oxygen Furnace and the traditional Open Hearth Process. Evaluations were based on actual records for five American plants covering three different time periods. The analysis considers how the attractiveness of the innovation was determined ex-ante and relative accuracy of the expected technological and economic expectations.

Boylan (1980) examines the effect of changes in the nature and mix of inputs on an otherwise essentially stable processing technology. The impact of beneficiation and agglomeration (pelletizing) of iron ore on blast furnace productivity is shown to transcend both the usually postulated models as well as the expectations of management themselves.

Luban and Dumitru (1982) present some results obtained while studying the substitution process of various processes on steel melting in Rumania. Simulating the substitution process leads to the conclusion that the substitution process is steady. The models can contribute to widening the investigative methods and techniques and can also be used for drawing certain development strategies in the ferrous metallurgical industry.

SCOPE FOR FURTHER RESEARCH

The steel industry is a target rich area for OR applications using the above techniques, both in developing and developed countries. Analysis of the growth of the steel industries in the last five years will demonstrate that more than 5% growth has occurred in three developing countries alone; namely India, China and South Korea. The challenges for OR applications and these techniques are different for developing and developed countries.

Specific research areas are:

1. Queuing Network Analyser

Most applications in an integrated steel plant are in closed loops using recycling of scrap, gas and energy. Though these have been considered as the constraint variables in deterministic production planning models, the application of a queuing network analyser has not been attempted. Also, most capacity calculations have been done in a deterministic set-up. However, in practice, most variables are stochastic in nature. Although trying to model and implement a queuing network model for all the applications of an integrated steel plant is a daunting task, such an attempt could be made allowing a better understanding of the production system.

2. Queuing Psychology

Although use of a queuing network analyser could lead to a better understanding of the production process, while studying such an application care should be taken to observe the psychology of the operators involved. As has been mentioned earlier, a lot of queues occur due to a particular psychological trait of the operator, rather than any production system faults. Thus an interesting study would be one of the inter-relation between operator psychology and occurrence of queues.

3. Production Control Methodology

Use of Materials Requirement Planning methods like JIT and KANBAN has been attempted a number of times in discrete part manufacturing industries leading to better inventory control. However, no such attempt has been reported from the process industry including steel. It would be interesting to study the effect of using such techniques in the steel industry, as the steel industry, unlike the discrete part manufacturing industry, has a diverging Bill of Materials.

4. Reliability Engineering and Management

An important facet of managing a steel plant is reduction in downtime for the various processes. Reliability rating of the equipment goes a long way in reducing the downtime. However, not much work has been reported in this area, especially in the developing countries. Unavailability of quality data is one of the prime hindrances in reliability studies in the steel plant.

5. Integrated Approach for Yield Improvement

Improvement of overall yield from liquid steel to finished steel should be one of the objectives for any simulation study. Most of the reported studies on simulation are based on some particular area of the steel plant. However, profitability of the steel plant is directly related to the overall yield. Therefore, the objective of a simulation study should be to maximize the overall yield rather than the yield in any particular operational area.

Glossary

Billets : Blooms are rolled into Billets. They are mostly square in the range of 50mm x 50mm to 125mm x 125mm.

Blooms : Ingots are rolled into Blooms. They have smaller cross-section than ingots and are square or slightly oblong mostly in the range of 150mm x 150mm to 300mm x 300mm.

Coils / Wire Rods : Smallest round sections of steel that can be produced by hot rolling. The sizes of rods vary from 5.5mm to 12.7mm. Generally,

rods are wound into coils about 760mm (30 inch) inside diameter and weigh from 450 to 2000 kilograms.

Continuous Caster : In this type of casting, slabs and billets are cast directly from the liquid metal bypassing the ingot stage.

Heat : Batch of Liquid Steel in a Steel Melting Shop approximately varies from 100 tons to 300 tons depending upon the technology and country.

Hot Strip Mill : The rolling mill that reheats and rolls steel slabs into hot bands, steel strips that are typically 0.10 inches thick and 50 to 60 inches wide.

Ingot : Liquid steel is cast into Ingots, which is nothing but individual molds of solidified liquid steel in the Steel Melting Shops. With Continuous Casters becoming more and more common in steel making, Ingots are tending to become obsolete.

Ladle : Ceramic lined open container used to transport and hold a heat of molten steel.

LD Shop : Linz Donawitz Shop Linz Donawitz is the name of the village in Austria where it was first developed.

Mixer : Reservoir for storing and heating Hot Metal from a Blast Furnace before it is sent to the steel melting shops. The purpose is to maintain the consistency of the composition, variation, and providing uniform temperature.

Pig Iron : Pig iron is the metallic product of the blast furnace containing over 90 % iron.

Pusher-Scraper : It is used to transport raw materials, like iron ore, from one point to another. Some pushers are also used in coke ovens to take coke out of the coke ovens.

Rolls : Rolls are the objects through which ingots are passed to produce finished steel. Also, it is used in other places essentially to reduce cross sectional area of the product.

Slab : The intermediate product from a continuous caster or a roughing mill. It is always oblong in shape, mostly 50 to 230mm thick and 610 to 1250 mm wide.

Slag : Slag is the fusible material formed by the chemical reaction of a flux with gangue of an ore, with ash from a fuel, or with impurities oxidized during the refining of a metal.

Surface Quality : The presence or absence of flaw in the surface of steel strip or sheet. The incidents of these flaws are extremely sensitive to the process of steel making and/or slab casting or Ingot teeming.

Teeming : Process by which molten steel is poured into ingot moulds.

Thermal Chamber Lateral Deformation : Deformation of refractories due to high temperature.

References

Albaharna, O. T. and Argyropoulos, S. A. (1988); Artificial Intelligence for Materials Processing and Process Control; Journal of Metals, October 1988, pp 6-10.

Amano, S.; Takarabe, T.; Nakamori, T.; Oda, H.; Taira, M.; Watanabe, S. and Seki, T. (1990); Expert System for Blast Furnace Operation at Kimitsu Works ; ISIJ International, Vol. 30, No. 2, pp 105-110.

Anabuki, Y.; Nakazi, S.; Iwamura, T.; Katae, T. and Ohnishi, T. (1996); Application of an expert system to real time coil transportation control of a steel finishing line ; Iron and Steel Engineer, January 1996, pp 30-35.

Anandalingam, G. And Bhattacharya, D. (1985) ; Process Modelling and Industrial Energy Use in Developing Countries --- The Steel Industry in India ; OMEGA, International Journal of Management Science, Vol. 13, No. 4, pp 295 - 306

Argyropoulos, S. A. (1990); Artificial Intelligence in Materials Processing Operations: A review and future directions; ISIJ International, Vol. 30, No. 2, pp 83-89.

Ashour, S. and Bindingnavle, S.G. (1972); An optimal design of a soaking-

Management Dynamics, Volume 6, Number 1 (2006)

pit rolling-mill system ; Simulation, Vol. 18, pp. 207-214.

Box, R.E. and Herbe, D.G. (1988); Scheduling Models for LTV Steel's Cleveland Works Twin Strand Continuous Slab Caster; Interfaces, Vol. 18, No. 1 (January - February), pp 42-56.

Boylan, M.G. (1980); Evaluating Input Charges in a Given Facility - Iron Making ; OMEGA (U.K.), Vol. 8, No. 5, pp 517-531.

Bruno, R (1971); A Simulation Application to the Study for Equipment Replacement in a Foundry Producing Centrifugal Pipes (Italian); Impianti (Italy), Vol. 4, No. 7-8 , pp11-19.

Buzacott, J.A. and Callahan, J.R (1971) ; The Capacity of the Soaking Pit - Rolling Mill Complex in Steel Production ; INFOR (Canada), Vol. 9, No. 2, pp 87-95

Buzacott, J.A. and Callahan, J.R (1973); A Pit Charging Problem in Steel Production ; Management Science, Vol. 20, No. 4, Part II, pp. 665-675.

Carmichael, D. G. (1987) ; Optimal Pusher-Scraper Loading Policies; Engineering Optimization, Vol. 12 No. 4, pp 255-267.

Chen Jian (1993); A Predicting System Based on Combining an Adaptive Predictor and a Knowledge Base as Applied to a Blast Furnace ; Journal of Forecasting, Vol. 12, pp 93-102.

Dangerfield, B. (1993); A systems modelling perspective on the scale effects in the steel industry; International Journal of Technology Management, Special Issue on "Manufacturing Technology", Vol. 8, Nos. 3/4/5, pp 371-383.

Dutta, G. and Fourer, R. (1996); A Survey of the Optimization Techniques in an Integrated Steel Plant; Presented at the IFORS Conference, 1996 at Vancouver.

Everett, J. E. (1996); Iron Ore Handling Enhance Export Quality; Interfaces, Nov.-Dec. 1996, Vol. 26, No. 6, pp 82-94.

Fabian, T.; Fisher, J.L. ; Sasieni, M.W. and Yardeni, A. (1959) ; Purchasing raw material on a fluctuating market ; Operations Research, Vol. 7, No.

1, pp. 107-122.

Ferguson, H. (1988); The Physical Simulation of Continuous Steel Processes; *Journal of Metals*, October 1988, pp 14-16.

Forrester, J.W. (1964) ; *Industrial Dynamics* ; M.I.T. Press

Ganguly, D. (1993); Simulation Study of Converter - Continuous Casting System at Bhilai Steel Plant; *Operational Research in Indian Steel Industry*, editors A.Tripathy and J.Shah ; pp 73-89.

Gercuk, M.Y.P. (1961); Linear Programming in Organization and Planning of Metallurgical Production (Russian); *Metallurgizdat*, pp 21-27.

Harris, C. R. and Yit, W. (1994); Successfully Implementing Statistical Process Control in Integrated Steel Companies ; *Interfaces*, Sept.-Oct. 1994, Vol. 24, No. 2, pp 49-58.

Hirao, F.; Takenaka, K.; Kuribayashi, T. and Hosoda, M. (1990); An expert system for efficient coil transfer in finishing line of hot strip mill; *ISIJ International*, Vol. 30, No. 2, pp 167-172.

Jimichi, Y.; Hori, A.; Ishihara, H. and Odaira, T. (1990); An expert system of automatic slab assignment for hot strip mill; *ISIJ International*, Vol. 30, No. 2, pp 155-160.

Kalro, A.H. , Raghuram, G. , Shukla, P.R. and Tripathy, A. (1993) ; Despatch Planning of Finished Steel Products at a Steel Plant ; *Operational Research in Indian Steel Industry*, editors A.Tripathy and J.Shah ; pp 113-124.

Kanemoto, M.; Yamane, Y.; Yoshida, T. and Tottori,H. (1990) ; An application of expert system to LD converter process ; *ISIJ International*, Vol. 30, No. 2, pp 128-135.

Katz, K. L., Larson, B. M. and Larson, R. C. (1991); Prescription for Waiting - in - line Blues: Entertain, Enlighten, and Engage; *Sloan Management Review*, Winter 1991, pp 44-53.

Khanna, A.K (1993); Determination of Optimum Number of Locos and Slag Ladles for Blast Furnaces - A Computer Simulation Approach;

Operational Research in Indian Steel Industry, editors A. Tripathy and J. Shah ; pp 56-72.

Kiuchi, M. and Yanagimoto, J. (1990); Computer aided simulation of universal rolling processes; ISIJ International, Vol. 30, No. 2, pp 142-149.

Kumar, R. (1983); Perspective Planning Model of a Steel Plant based on System Dynamics Principles ; *Dynamica* 9(2):

Lankford, W.T., Samways, N.L., Robert, F.G. and McGannon, H.T. (1985); *The Making, Shaping and Treating of Steel*; Unites States Steel, 10th Edition.

Lin, C. and Moodie, C. L. (1989); Hierarchical production planning for a modern steel manufacturing system; *International Journal of Production Research*, Vol. 27, No. 4, pp 613-628.

Lock Lee, L.G.; McNamara, A.C.; Teh, K.C.; Lie, H.M.; Orenstein B.J. and Brown D.J.H. (1990); Rapid prototyping tools for real-time expert systems in the steel industry ; *ISIJ International*, Vol. 30, No. 2, pp 90-97.

Luban, F. and Dumitru, V. (1982); On some models and methods of forecasting technological changes ; *Econ. Comp. & Econ. Cyb. Stud. & Res. (Romania)*, Vol. 17, No. 1, pp 59-65.

Maity, B.R. and Jain, M. (1993); An Effective Coal Blending System under Conditions of Variable Receipt Pattern; *Operational Research in Indian Steel Industry*, editors A. Tripathy and J. Shah ; pp 34-49.

Malu, R.K. (1993); Application of Taguchi Concepts in Quality Engineering in a Tube Manufacturing Shop; *Operational Research in Indian Steel Industry*, editors A. Tripathy and J. Shah ; pp 172-179.

Massobrio G. (1971); Problems related to the introduction of OR in the Organization of a Steelplant ; *Ricerca Operativa (Italy)*, Vol. 1, No. 3, pp 5-13.

Mathieu, J.C. (1962); *Integrated Planning in a Steel Works* ; *Operational*

Research Quarterly (U.K.), Vol. 13, No. 4, pp 329-343.

McNamara, J. A. and Woodyatt, L. R.; Rod Mill Billet Surface Quality Reporting System ; Bethlehem Steel Corporation, Bethlehem, PA 18016.

Mellor, P. and Tocher, K.D. (1963); A Steel Works Production Game; Operational Research Quarterly (U.K.), Vol. 14, No. 2, pp 131-135.

Mihailor, M.O.A. (1961); Mathematical Statistics and Linear Programming in Ferrous Metallurgical (Russian); Metallurgizdat, pp 160.

Montaldo, R (1972); A Simulation Model for an Ingot Molds Foundry (Spanish); Impianti (Italy), Vol.5, No. 12, pp 9-17.

Narazaki, H.; Iwatani, T.; Omura, K.; Otsuka, Y and Konishi, M (1990); An AI tool and its application to diagnosis problems ; ISIJ International, Vol. 30, No. 2, pp 98-104.

Narchal, R. M. (1988); A Simulation Model for Corporate Planning in a Steel Plant ; European Journal of Operational Research (Netherlands), Vol. 34(3), pp 282-296.

Niwa, Y.; Sumigama, T.; Sakurai, M. And Aoki, T. (1990); Application of a self learning function to an expert system for blast furnace heat control ; ISIJ International, Vol. 30, No. 2, pp111-117.

Ogai, H.; Ueyama, T.; Sato, H.; Mishima, Y. and Itonaga, S. (1990) ; An expert system for quality diagnosis of glass films on silicon steels ; ISIJ International, Vol. 30, No. 2, pp 173-181.

Otsuka, K.; Matoba, Y.; Kajiwara, Y.; Kojima, M. And Yoshida, M. (1990); A hybrid expert system combined with mathematical model for blast furnace operation ; ISIJ International, Vol. 30, No. 2, pp 118-127.

Peaslee, K. D. (1996); Physical Modelling of slag splashing in the BOF ; Iron and Steel Engineer, November 1996, pp33-37.

Portmann, N. F.; Lindhoff, D.; Sorgel, G. and Gramckow, O. (1995); Application of neural networks in rolling mill automation ; Iron and Steel Engineer, February 1995, pp 33-36.

Rao, P.P. ; Singh, R.; Rao, V.S. and Mohanty, R.P. (1993); Applications

of Operational Research Techniques in Steel Industry : A Classificatory Review; Operational Research in Indian Steel Industry, editors A.Tripathy and J.Shah

Van Roey, J. ; Vergote, H. and Mielke, R. (1996); Accurate profile and flatness control on a modernized hot strip mill ; Iron and Steel Engineer, February 1996, pp 29-33.

Rosegger G (1980); Comparing a New Technology with its Predecessor - Steel Making ; OMEGA (U.K.), Vol. 8, No. 5, pp 533-543.

Sasabe, Y.; Kubota, S.; Koyama, A. And Miki, H. (1990); Real-time Expert system applied to mold bath level control of continuous caster ; ISIJ International, Vol. 30, No. 2, pp 136-141.

Sasaka, S.; Kozaki, Y; Chida, Y.; Kotake, T.; Fukuda, F. and Satoh, T. (1990); Fully automated bar mill pacing control system incorporating artificial intelligence ; ISIJ International, Vol. 30, No. 2, pp 161-166.

Sastry, S.S. , Panigrahi, S. and Desai, M.K. (1993); Improvement in the Ingot to Slab Yield Per Cent through Application of Simulation Technique ; Operational Research in Indian Steel Industry, editors A.Tripathy and J.Shah

Shah, J. and Tripathy, A. (1993); Operational Research in Indian Steel Industry

Sinha, G. and Dutta, G. (1985); A System dynamic Model of a Blast Furnace for Project Evaluation; Proceedings of International Conference of System Dynamics Society, pp838 - 851.

Srivastava, S. (1993); Using Mental Model to Enhance the Effectiveness of a Symbiotic Decision Support System: Application to Steel Plant Scheduling ; Ph.D. Dissertation, Northwestern University, Chicago, USA.

Sugawara, S. and Takahashi, M.(1965) ; On Some Queues Occurring in an Integrated Iron and Steel Works ; Journal of the Operations Research Society of Japan, Vol. 8, No. 1, September 1965, pp. 16-23.

Thomas, G.W. (1963); Operational Research in Steel Company of Wales;

- Operational Research Quarterly (U.K.), Vol. 14, No. 3, pp 247-262.
- Thorsen, M. N. and Vidal, R. V. V. (1991) ; Operational Research in Danish Steel Industry ; European Journal of Operational Research , No. 51, pp 301-309.
- Uchiyama, T. and Sugahara, S (1962); Determining the Optimal Capacity of Ingot Reheating Furnace; OR JUSE (Japan), Vol. 6, No. 5, pp 44-48.
- Vyas, M.M. (Research Department); Renn, D.J. (Research Department) and Harpster, S.M. (Steelton Plant) (1990); An Expert System to Recommend Roll Adjustments in a Rail Mill, Bethlehem Steel Corporation, Bethlehem, PA 18016, USA.
- White, D. J. (1985); Real Applications of Markov Decision Processes; Interfaces, Vol. 15, No. 6, November-December 1985, pp 73-83.
- Williams, N.J. (1967); Use of computer techniques for planning and organization in a steel plant; Journal of the Iron and Steel Institute, Vol. 116, August 1967, pp. 832-836.
- Woodall, A. ; Sanders, K.H. and Walker, J.A. (1970) ; Model Building with Particular Reference to the Use of Productive Capacity ; Journal of the Iron and Steel Institute , Vol. 209, May 1970, pp. 434-438.
- Woodyatt, L. R. (1990); Bethlehem Steel's Roll Supplier Rating System; Research Department, Bethlehem Steel Corporation, Bethlehem, PA 18016, USA.
- Woodyatt, L. R. and McNamara, J. A.; Steel Plant Roll History System; Research Department, Bethlehem Steel Corporation, Bethlehem, PA 18016, USA.
- Woodyatt, L. R. and McNamara, J. A.; Sheet Product Conformance Reporting System ; Research Department, Bethlehem Steel Corporation, Bethlehem, PA 18016, USA.
- Woodyatt, L. R. and Popp, R. S.(1991) ; Roll Performance Computations For Strip Mills ; Research Department, Bethlehem Steel Corporation, Bethlehem, PA 18016, USA. Appendix.

Appendix

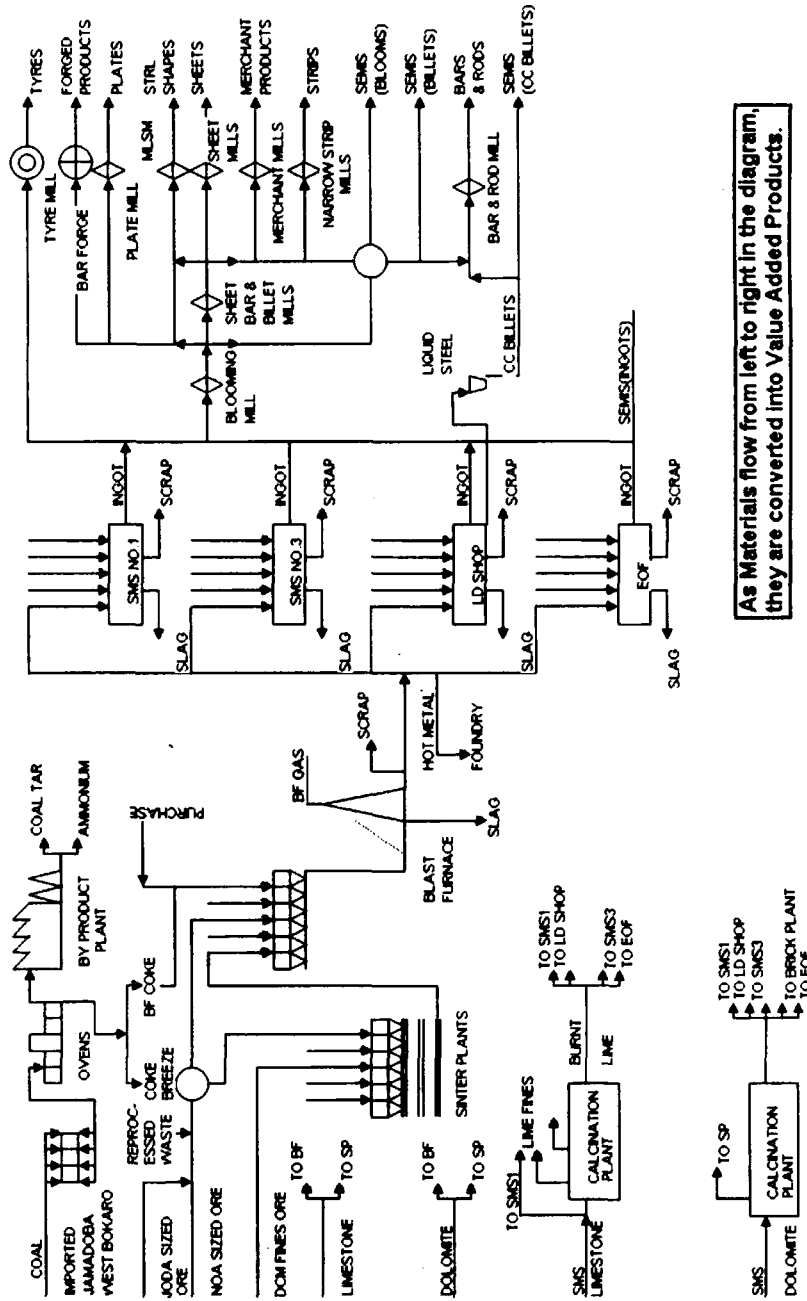

As Materials flow from left to right in the diagram, they are converted into Value Added Products.