



Effective Harnessing of Energy from GSM Receiving Antenna Array as a Source for Low Power Applications

Mrs. V. P. Kodgirwar^{#1}, Dr. S. B. Deosarkar^{*2}, Dr. Mrs. K.R. Joshi^{#3}

E&Tc Department, Modern College of Engineering, Pune 411005. #1, #3

*E&Tc Department, BATU, Lonere. *2*

Abstract : *This research work presents, design of five element array to investigate the power level that can be harvested from surrounding and processed to charge up low power electronics circuits and devices. This novel idea is implemented for the GSM band applications. Wireless energy available in the environment is received by the receiving Dipole Antenna Array which is designed for frequency 947.5MHz, the center frequency of the GSM downlink band 935 – 960MHz. The received energy is stored and multiplied with electrolytic capacitors to drive low power devices. Further this RF energy is converted into Dc voltage with bridge rectifier.*

I. Introduction

The ever increasing use of wireless devices, such as mobile phones, radio broadcasts, wireless computing and remote sensing has resulted in an increased demand and reliance on the use of batteries [4]. With semiconductor and other IC technologies continually striving towards lower operating powers, batteries could be replaced by alternative sources, such as DC power generators employing various energy harvesting techniques [5].

With the growth of GSM users in the country every operator has installed powerful transmitters and this energy is available for use other than mobile applications but not harnessed as on date for its other applications [4]. Hence the need of development of such applications which can be used effectively this available energy [3]. On the other side the need of energy is increasing day by day and we need additional sources particularly for the areas where electrical transmission line construction is not feasible because of forest or water or economic reasons [1].

The major issue concerning the scientist nowadays is the excessive use of natural gas and petroleum. It has been predicted that these resources will be exhausted in the next two or three decades. The over consumption of petroleum and natural gas has also caused adverse effect on the environment. The scientists are trying hard to find the alternate sources of renewable energies and reduce the dependence on petroleum and natural gas [2]. One such alternative is “radio frequencies”. The radio frequencies are electromagnetic energy which travels through the air by ionizing the medium on its paths.

In the modern environment there are multiple wireless sources of different frequencies radiating power in all directions [5]. These sources might be, TV and radio broadcasts, mobile phone base stations, mobile phones, wireless LAN and radar, telecommunication, microwave devices etc. It is ubiquitous and free and highly efficient [4].

The dipole antenna is designed and tuned to frequency 947.5MHz. At this frequency the energy is received and it is stored in the parallel combination of electrolytic capacitors. These capacitors will charge when they are connected to antenna and will discharge through the load.

In second part of this paper design calculation for simple dipole is explained. In next part of paper how dimensions of dipole is changed to get proper results are shown. In fourth part experimental results for return loss and VSWR are shown. In fifth part circuit design and simulation results for RF-DC conversion is explained. Then next part consists design, fabrication and testing for array with five elements. Finally complete work is concluded.



II. Antenna Design

A simple dipole antenna is designed for the GSM downlink frequency band 935 to 960MHz because it is receiving antenna which receives energy from the environment. For designing dipole antenna the length of antenna is calculated for the desired frequency. Half wave dipole antenna is designed. The length of dipole is calculated $\lambda/2$ according to the design equations. The higher frequency is 960MHz and lower frequency is 935MHz. Hence the bandwidth is given by

$$\text{Bandwidth} = f_h - f_l = 960 - 935 = 25\text{MHz}$$

The center frequency and wavelength is given by,

$$\begin{aligned} \text{Center frequency } (f_c) &= (f_h - f_l)/2 + f_l \\ &= (960 - 935)/2 + 935 \\ &= 947.5\text{MHz} \end{aligned}$$

$$\begin{aligned} \text{Wavelength } (\lambda) &= c/f_c \\ &= (3 * 10^8) / 947.5\text{MHz} \\ &= 0.316623 \text{ m} \\ \lambda/2 \text{ in cm} &= (\lambda/2) * 100 \\ &= 16 \text{ cm} \end{aligned}$$

III. Antenna Design Analysis

For the analysis and study purpose the frequency band GSM 900 is used. In which uplink frequency band is 890 – 915MHz and downlink frequency band is 935 – 960MHz. For this study the selected band is 935-960MHz. Initially antenna is fabricated on simple wooden part and the two poles are fitted on it and the loop is connected to it. Initially the dipole is fabricated with length 16cm as shown in fig1.



Fig 1: Dipole with length 16cm tuned at 879MHz

After checking the results on network analyzer it has been found that center frequency is shifted to 879MHz which is undesired. Return loss graph was not as per requirement.

Although calculated length of dipole was 16cm but this antenna could not give desired results. Therefore to increase the operating frequency, length of dipole is reduced. So the length of the dipole is made 15cm and the loop used is also 15cm long. This antenna gave us desired results and it is appropriately tuned to 947.5 MHz. Now this antenna is capable of receiving frequencies in the GSM downlink band 935MHz – 960MHz. And this will act as input to the further electronic circuit.

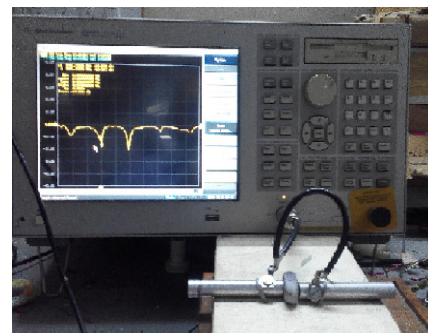

Fig. 2. Testing of antenna with length 15cm

Also with 16 cm dipole simple connectors were used therefore results were not coming properly. So for the next attempt another type of connectors (BNC) are used. These connectors properly matched with the transmission line. The dipole at length 15cm gave the correct results. Return loss graph is tested on VNA and this dipole is tuned at 947.5 MHz as shown in figure 2.

IV. Practical Antenna Design and its Results

Above antenna is designed only for study and analysis purpose. For practical application point of view the antenna is fabricated with aluminum pipe of 1mm thickness and its length is 13.8cm which is less than the previous design. Because the frequency and radius are inversely proportional to each other, the length is decreased as the radius is increased [2]. The image of antenna and results of this antenna are as given in figure 3, 4 and 5 respectively. Received power of this antenna is measured on Spectrum Analyzer.



Fig 3. Single fabricated dipole antenna
13.8cm

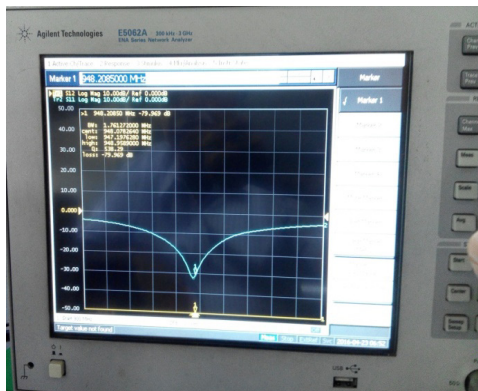

Fig 4. Return loss graph for dipole with
length 13.8cm

As shown in figure 4 the reflection coefficient (S11) is measured on vector network analyzer and it shows that the dipole is capable of receiving frequency 947.5 MHz completely and return loss at this frequency is up to -32dBm. Also the graphs of VSWR and return loss are shown in figure 5. VSWR at frequency 947.5MHz is 1.8 which is quite acceptable.

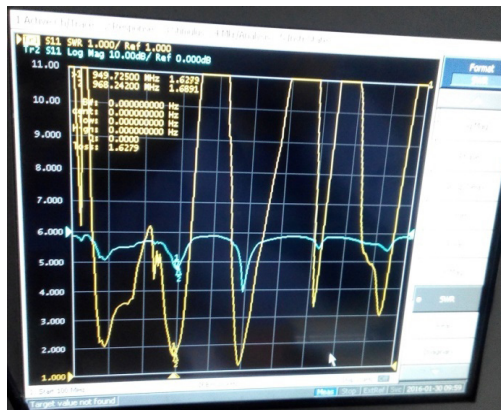

Fig 5. Return loss and VSWR graph on
Network Analyzer

The received signal strength of antenna is measured on spectrum analyzer and it shows that dipole antenna can give the maximum output is, 20dBm (100mW) which has an equivalent rms voltage of 2.24V.

a. RF-DC Conversion Circuit Design

RF to DC conversion circuit is used to convert the ambient energy available in the environment into equivalent electric energy [3]. This circuit is designed using ceramic capacitors and diodes which gives the appropriate dc output.

The design and simulation of this circuit is done using Multisim software [4]. Voltage multiplier and a Rectifier is designed for the conversion of RF energy into DC Voltage. The geometry of voltage multiplier is designed using zero biased schottky diodes and ceramic capacitors. The rectifier is designed using fast recovery diodes. The model number of Zero biased schottky diodes is 10BQ015. Fast recovery diodes (1BH62) are used to construct the rectifier. The geometry of this design is shown in figure 6.

A voltage multiplier is designed with multiple stages. The output voltage of a voltage multiplier have almost 1.5 times the peak input voltage due to their high impedance, caused in part due to the fact that as each capacitor in the chain supplies power to the next stage, and it partially discharges, loses some amount of voltage and so on. The output of the multiplier gets converted into high dc voltage by the Bridge Rectifier.

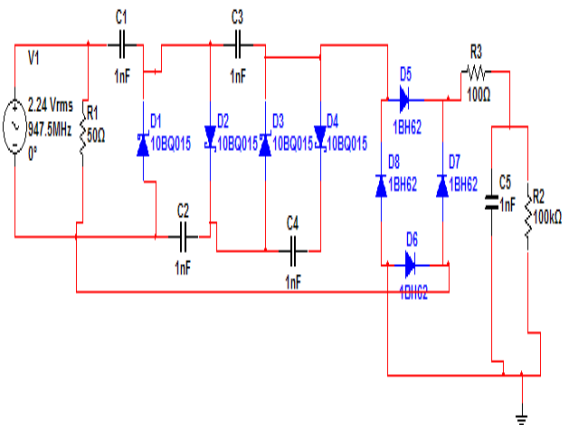

Fig 6. RF – DC Conversion Circuit for the
system



b. Simulation Results for RF-DC Conversion Circuit

For simulation of this voltage multiplier circuit Multisim software is used [4]. The input is taken as 2.24 V with 947MHz frequency, which after simulating the circuit gives a stable output DC Voltage of 2.73 V DC across 100kΩ load. Since the antenna output port is directly fed into the input port of the circuit through connectors, the RF energy received by the antenna output port is taken as the input for the circuit. The circuit design and simulation is shown in figure 7 below.

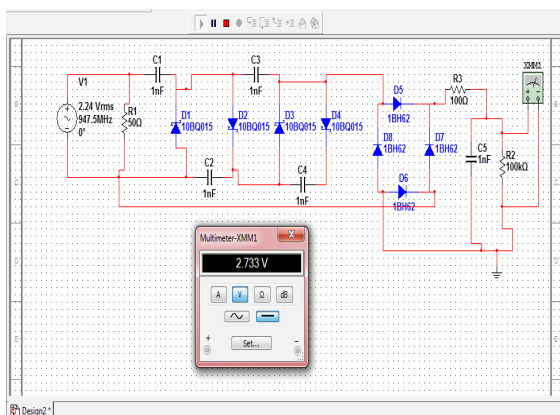

Fig 7. Simulation result of the circuit at 947.5 MHZ

After getting simulation results for RF-DC circuit we have designed and fabricated array with five elements to improve overall gain. This array is shown in figure 10. Antenna Arrays precisely is the mechanism by which we can realize complex radiation patterns without significantly altering the antenna impedance.



Fig.8. Array with five elements

Usually the radiation pattern of a single element antenna is relatively wide, and single element provides low values of directive gain.

In many applications it is necessary to design antennas with high directive characteristics that is with very high gains to meet the demands of long distance communication. This can only be achieved by increasing the electrical size of the antenna. To provide high directive patterns, it is necessary that the fields from the elements of the array interfere constructively (addition) in the desired directions and interfere destructively (cancel each other) in the remaining special area. The simplest and one of the most practical arrays are formed by placing the number of elements along a line.

To construct the array, the spacing between the elements is kept $\lambda/2$ and five elements of equal specification are placed on a square aluminum pipe which acts as common ground to all the elements. The geometry of array with RF-DC conversion circuit is presented in figure 9. Output voltage of this design is 2.68 volts which is measured across 100kΩ load. This was very less than our expectations because in array gain should be improved according to pattern multiplication rule.



Fig 9. Hardware of the RF-DC Conversion circuit with Array

Based on measurements and simulations, it can be concluded that it is possible to use radiated, off-air RF signals can be used as a source for energy harvesting. Even though the output powers of such harvester are relatively low.

Dipole with 16 cm, 15 cm and then 13.8 cm is designed, fabricated and tested to investigate the levels of power that can be harvested from the surrounding environment and processed to achieve levels of energy that are sufficient to



charge up low- power electronic circuits and devices. This analysis and study is for the GSM band with downlink frequency 935 – 960MHz. Receiving Dipole antenna is designed and tuned for frequency 947.5MHz which is the center frequency of the GSM downlink band 935 – 960MHz. The received energy can be used to drive the low power circuits.

References

1. Taris Thierry, Vignerat Valérie, Fadel Ludivine, “A 900MHz RF Energy Harvesting Module”, 978-1-4673-0859-5/12/\$31.00 ©2012, IEEE.
2. Lim Teck Beng, Lee Ngai Meng, Poh Boon Kiat, and Thiha Kyaw, “Pervasive RF Energy Harvesting System”, 2014 IEEE Conference on Technologies for Sustainability (SusTech)
3. Deep Patel, Rohan Mehta, Rhythm Patwa, Sahil Thapar and Shivani Chopra, “RF Energy Harvesting”, International Journal of Engineering Trends and Technology (IJETT) – Volume 16 Number 8 – Oct 2014.
4. A.C. Patel, M.P. Vaghela, H.Bajwa, P.K.Patra, “ Power Harvesting for Low Power Wireless Sensor Network”, 2009 Loughborough Antennas & Propagation Conference 978-1-4244-2721-5/09/\$25.00 ©2009 IEEE
5. Dr J C Batchelor and Dr PS Taylor, “Radio Frequency Energy Harvesting Project”, Final Report for Science Faculty REF Fund.
6. D. Pavone, A. Buonann, M. D’Urso² and F. D. Corte, “Design Considerations For Radio Frequency Energy Harvesting Devices”, Progress In Electromagnetic Research B, Vol. 45, 19-35, 2012.
7. N. M. Din, C. K. Chakrabarty, A. Bin Ismail, K. K. A. Devi, and W.-Y. Chen, “Design of RF Energy Harvesting System for Energizing Low Power Devices”, Progress In Electromagnetics Research, Vol. 132, 49-69, 2012
8. Arghya Sahoo, Neelaveni Ammal, “Design of Antenna System to harvest RF Energy for Generating Electricity”, International Journal on Recent and Innovation Trends in Computing and Communication ISSN: 2321-8169 Volume: 3 Issue: 1
9. U. Olgun C.-C. Chen J.L. Volakis, “Design of an efficient ambient WiFi energy harvesting system”, Published in IET Microwaves, Antennas & Propagation.
10. Chang-Jun Ahn, “Development of RF Energy Harvesting and Charging Circuits for Low Power Mobile Devices”, Graduate School of Engineering, Chiba University 1-33 Yayoi-cho, Inage-ku, Chiba-shi, Chiba, 263-8522 Japan.
11. Mahima Arrawaita, Maryam Shojaei Baghini, Girish kumar, “RF Energy Harvesting Systems from Cell Towers in 900 MHz Band”, IEEE Journal.