



Printing Machine Uv Lamp Temperature Control Panel

Pritika Arvind Patil, Prof. Shilpa Joshi,

P.E. Society's Modern College of Engineering, Pune.

ABSTRACT :

Printing is done for various aspects such as for decorating purpose, information shearing through magazine, news paper, books, on textile etc. The design or text is printed on cloth or paper or wood. In printing there is problem to cure (dry) the ink after print. If it is not cure as early then there is possibility to sprayed the ink. The aim of this project is to control various aspects of curing such as level of ink, temp of lamp, moisture/humidity of ink and speed of fan by using PLC & Microcontroller.

Ink is spared over it which is needed to cure or dry. To fulfill this requirement a continuous monitoring and controlling is required. Monitoring is achieved by using Microcontroller.

Microcontroller translate the data on PC, all required levels for curing is set by microcontroller. Microcontroller set the level of ink, temperature level of UV lamp, moisture level of ink and speed of blowers.

I. INTRODUCTION

The curing of various surface coatings with light can be traced back many centuries to the time the ancient Egyptians cured resin soaked mummy wrappings by sunlight. Since then, innumerable photochemical reactions have been discovered. However, there was no commercial photo curing process until the 1960's. Finally, in the late 1970's, rapid advances in technology made UV curing inks and coatings commercially viable.

Ultraviolet curing (commonly known as UV curing) is a photochemical process in which high-intensity ultraviolet light is used to instantly cure or "dry" inks, coatings or adhesives. Offering many advantages over traditional drying methods, UV curing has been shown to increase production speed, reduce reject rates, improve scratch and solvent resistance, and facilitate

superior bonding.

Using light instead of heat, the UV curing process is based on a photochemical reaction. Liquid monomers and oligomers are mixed with a small percent of photoinitiators, and then exposed to UV energy. In a few seconds, the products - inks, coatings or adhesives instantly harden.

UV curable inks and coatings were first used as a better alternative to solvent-based products. Conventional heat- and air-drying works by solvent evaporation. This process shrinks the initial application of coatings by more than 50% and creates environmental pollutants. In UV curing, there is no solvent to evaporate, no environmental pollutants, no loss of coating thickness, and no loss of volume. This results in higher productivity in less time, with a reduction in waste, energy use and pollutant emissions.

In recent years, UV curing technology has evolved to the extent that it can now be applied to three dimensional parts.

Previously we were using PLC for this process. PLC Control of UV Lamp where UV lamp temperature is controlled with the help of PLC. A sensor is use to sense the proper temperature which should not damage the printing area. Sensor sends the information in the form of current which is given to the PLC. Analog module is connected in between PLC and sensor, it convert analog information of sensor to digital for. Initially a particular temperature is set within PLC then it takes decision to turn ON or OFF the blower through contactor. If temperature is more than set value then PLC turn on the blower so it minimize the temperature also reduce the intensity of UV lamp. In this way we maintain the temperature of UV lamp during the whole process of printing.

PLC can communicate with IPC through



PC Access. In order to collect multi-loops temperature data and send control commands, the measurement and control program is written by PLC

Microcontrollers are special types of processor chips that are very small and somewhat versatile, due to their programmable nature. This type of processor is fully integrated, a “computer on a chip,” unlike general purpose processors that people use in their home PCs and laptops. Programmable logic controllers (PLCs) are a subset of microcontrollers that are specifically designed to carry a set of instructions for manufacturing robots and industrial equipment designed for specific automated tasks.

But there are many problems such as burning paper if the heat of UV lamp increases. In this project we have designed such type of controller which fully works automatically. We take 3 parameters Temperature, Level and Moisture. If the temperature of UV lamp increases its sets threshold value then automatically switched off the UV lamp and the blower (fan) will start to reduce the temperature. If the ink level reduces below the threshold value, we get the message and the conveyor belt motor stop and if the moisture level is above the set value then we cure that moisture by PWM technique.

II. PROPOSED WORK

The proposed work is more concentrate with microcontroller over PLC. A microcontroller is also a logic controller but used in dedicated systems which are programmed once and for all, the program for which will not be accessed by the user, and whose program will not need to be altered frequently. Microcontrollers Developed for Dedicated equipments. Development Time is more. With a microcontroller, you can design your own signal interfacing.

BLOCK DIAGRAM

Block diagram description.

1. Microcontroller : It is heart of the system. It dedicatedly controls various aspect of the system. It is use to drive and control the speed of the conveyer belt. It continuously compares the different sensor input with the predefine values and provide the digital date output on PC

for monitoring purpose. The data is passing to PC by using MAX 232 serial data input.

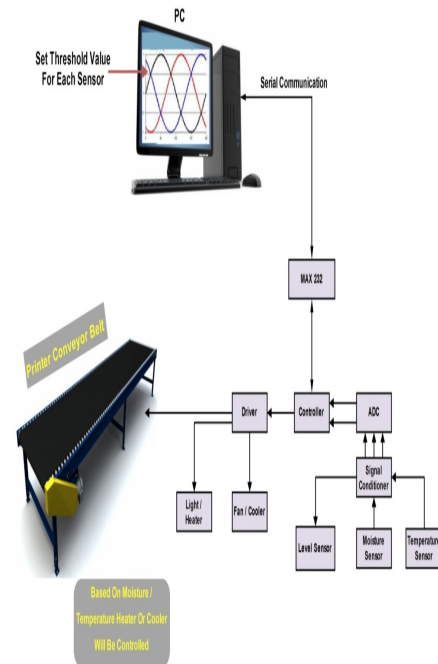

Fig.1. Block diagram of proposed work of the system

2. Driver : It is use to drive heater, fan and conveyer belt. The voltage out provided by microcontroller is very less around 5V which is not sufficient to run the device and motors. The driver amplifies the signal and provides desire voltage range. Two drivers IC is used Device driver IC ULN2003 and motor driver IC L293D. The driver provides 12volts to the motor and device for operation.

3. ADC : It converts the analog signal from the sensor to digital signal and provide the digital data to controller for controlling purpose.

4. Signal Conditioner : It acts as Filter and provide desire noise free analog signal to ADC.

5. Sensors: three sensors are provided to detect and manage the working of curing process.

i. Level Sensor : It measures the ink level from ink tank.

ii. Moisture Sensor : It detects the moisture contain of ink. The moisture contains helps to identify the amount of heat provision.

iii. Temperature Sensor : It detects the temperature of UV lamp. This is used to avoid



unnecessary burning of work space.

6. Fan/cooler : it is use to maintain the UV lamp temperature.

7. UV lamp: The major unit for curing process.

Circuit Description:

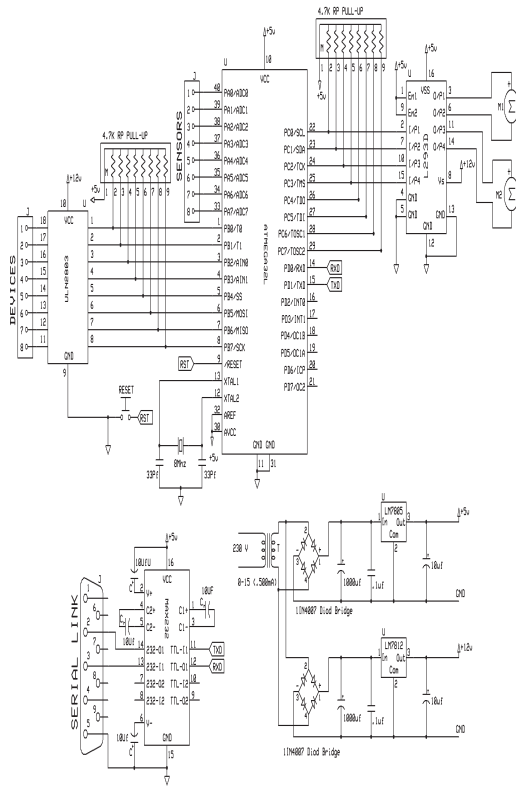

Fig.2. Circuit diagram

Fig.1 shows the block diagram of system. Sensors are used to sense the temperature, moisture/humidity and level. These sensed values are goes through the signal processor. Controller knows the digital values hence these sensed analog values are converted into digital values using analog to digital converter (ADC). The Microcontroller forms the heart of the project because it controls the devices being interfaced and communicates with the devices according to the program being written. In controller, initially a particularly temp is set then it takes decision to turn ON or OFF the blower through contactor, also controls the intensity of the UV lamp using dimmer circuit. Here we are using MAX-232 to have compatibility between the PC and microcontroller. PC is basically meant to show up the status of the project. Generally use of Liquid Crystal Display to display/ prompt for necessary information.

I. RESULTS

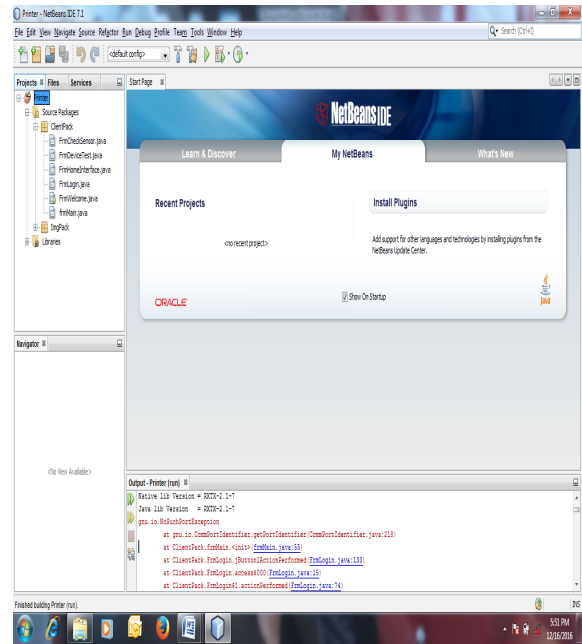

Fig. 3 : Netbeans IDE

Fig. 3 shows the running window of the software Netbeans



Fig. 4 : Printer control window

Fig. 4 shows the printer controlling window where we can select the communication port.

Here we have selected COM port 12.

COM port 12 belongs to these specific device, in case of other device we can select other port depending on which port we have connected the device.

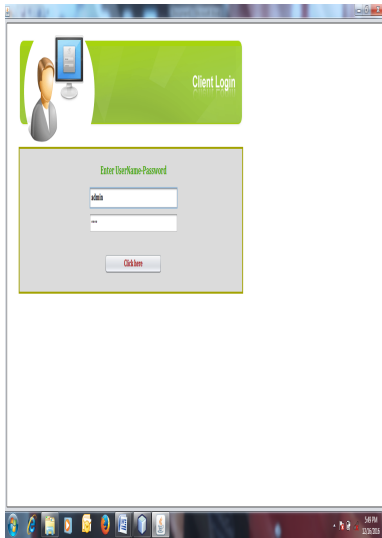

Fig. 5 : Client login window

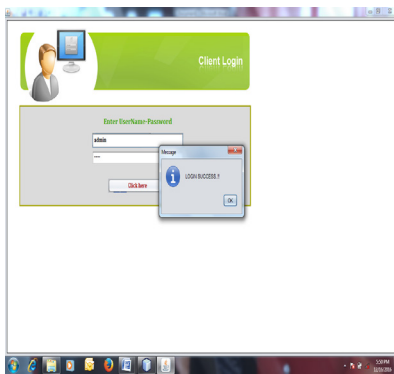

Fig. 6 : Client Login

Fig. 6 shows the Login window.

By entering the credentials we can login to the application.

Here the credentials used are below:

User Name : admin Password : admin

Fig. 6 shows the login success window after entering the credentials



Fig. 7 : Activitis window

Fig. 7 shows the activities which we can perform.

Here we can check the devices, sensors.

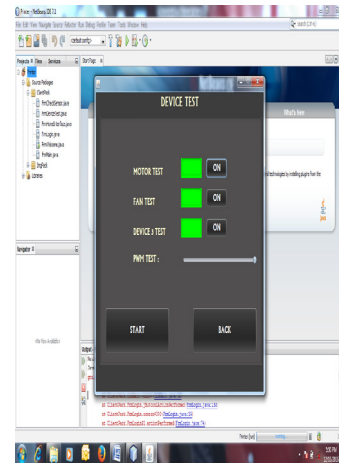

Fig. 8 : Device test window

Here we can see we can test the motor, the fan, lamp and the Pulse width modulation of the device.

By turning On and OFF the buttons we can check whether the device are working or not.

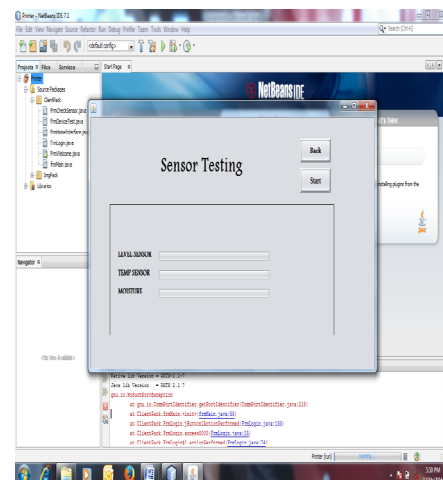
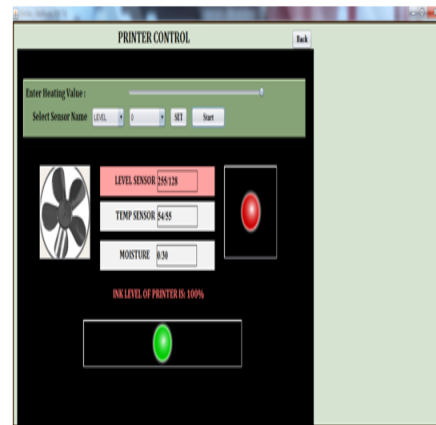

Fig.9 : Sensor testing window

Fig 9 shows the Sensor testing window.



Referring Fig 8, when we hit the run button we get the main window where we can set the threshold values of level, temperature and moisture.

Fig If ink level is below set value

We have set the threshold value for level sensor as 128.

If the value is less that the set value we get an alert message as “REFILL INK ALERT:INK LEVEL OF PRINTER IS LOW”

At this point th motor will automatically get stop.

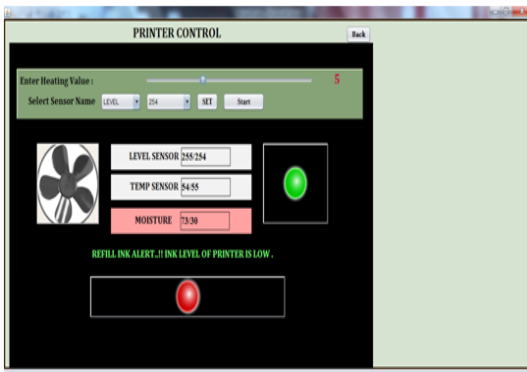

Fig. 10 If Ink level is above set value

If the set value is more than the threshold value we get a message as “INK LEVEL OF PRINTER IS 100%”

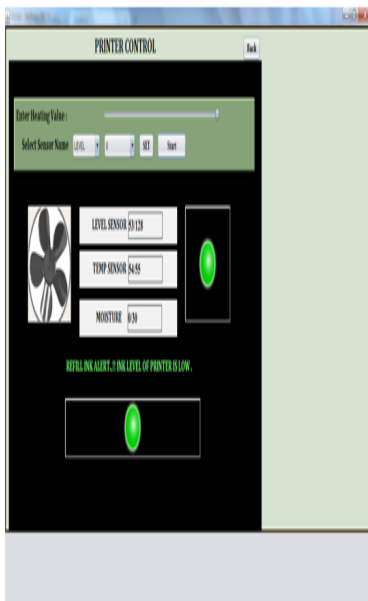

Fig. 11 If moisture is above set value

If moisture is above set value then we control the lamp intensity by PWM method.

If the set value of temperature is more than the threshold value then fan starts running automatically to adjust the temperature.

I. Conclusion

		FAN	LAMP	MOTOR	RESULT
TEMPERATURE	Less	OFF	ON	ON	Normal working
	Greater	ON	ON	ON	Control the temperature of lamp by PWM technique
LEVEL	Less	No change	No change	OFF	REFILL INK ALERT: INK LEVEL OF PRINTER IS LOW”
	Greater	No change	No change	ON	INK LEVEL OF PRINTER IS 100%”
MOISTURE	Less	No change	No change	No change	
	Greater	OFF	ON	No change	Control the temperature of lamp by PWM technique

References

- 1) J. Y. Zhang, I. W. Boyd, “Lifetime investigation of excimer UV sources, ” Applied surface science, vol. 168, pp. 296-299, December 2000.
- 2) M. Laroussi, X. Lu, V. Kolobov, and R. Arslanbekov “Power consideration in the pulsed dielectric barrier discharge at atmospheric pressure, ” J. Appl. Phys, vol. 96, 3028, 2004.
- 3) R. P. Mildren, and R. J. Carman, “Enhanced performance of a dielectric barrier discharge lamp using short-pulsed excitation, ” J. Phys. D: Appl. Phys. , vol. 34, No 1, L1-L6, January 2001
- 4) Tansheng Zhou, Jianjun Dong, Zongquan Song. Application study of digital PID controller in cockpit temperature auto-regulating system, Journal of Measurement Science and Instrumentation, 2 (2013) 190-193.



- 5) Ali EtemGurel, IlhanCeylan. Thermodynamic analysis of PID temperature controlled heat pump system, *Case Studies in Thermal Engineering*, 2 (2014) 42-49.
- 6) Tomas Nahlovsky, Optimization of Fuzzy Controller Parameters for the Temperature Control of Superheated Steam, In 25th DAAAM International Symposium on Intelligent Manufacturing and Automation (DAAAM 2015), 100 (2015) 1547-1555.
- 7) Lei Wang, Wencai Du, Hai Wang, Hong Wu, Fuzzy self-tuning PID control of the operation temperatures in a two-staged membrane separation process, *Journal of Natural Gas Chemistry*, 17. 4 (2008) 409-414.