

## Automobile Automation

R. Amudhevali<sup>1</sup>, Dr. T.V.U. KiranKumar<sup>2</sup>, Ms. S. Arulsevi<sup>3</sup>

<sup>1</sup>R. Amudhevali, Department of Electronics and Communication Engineering, Bharath University, Selaiyur, Chennai - 600 073, Tamil nadu, India.

<sup>2</sup>Dr. T.V.U. KiranKumar, Professor & HOD, Department of Electronics and Communication Engineering, Bharath University, Selaiyur, Chennai - 600 073, Tamil nadu, India.

<sup>3</sup>Ms. S. Arulsevi, Assistant Professor, Department of Electronics and Communication Engineering, Bharath University, Selaiyur, Chennai - 600 073, Tamil nadu, India.

Corresponding author: R. Amudhevali, Department of Electronics and Communication Engineering, Bharath University, Selaiyur, Chennai - 600 073, Tamil nadu, India. Email: amuthavallirajan@gmail.com

### Abstract

India is the world's largest market for automobiles. Latest new models with improved fuel efficiency and power ratings keep hitting the market off and on. Sadly, the security aspects of automobiles remains neglected. This fallibility inspired to devise a foolproof yet cost – effective security system to safeguard automobile against theft. Nowadays some of the automobiles come with remote controllers. However, no such facility is provided for normal automobiles. Such automobiles controllers are not available even in kit form. For long time, the need for car automation and auto control under various traffic and visibility conditions has been felt. Now the same have become possible through micro controller based intelligent system, which can do every thing the same as human being does. Automated machines are becoming more intelligent aided by micro electronics, sensors, microcontrollers and programmable software. In this project PIC microcontroller 16F877A as well as AT89C2051 are acting as a primary controller and the word “Intelligent Controller “ will never be spelled out with out this kind of controllers .According that this project is not only mimics the entire thing that the normal human being has done but also it is acting as an intelligent controller. This automobile automation processor has enhanced features and can be easily customized to meet individual requirements as it is programmable. Its main features are the alarming system which enables to know, at the earliest when any unknown person opens the door of the car. These system responses automatically to the atmospheric conditions, actuating automatic wiper control and dipper light control. The entire process is interfaced with personal computer through RS232 to exploit the full features of automobile automation.

**Keywords:** Atmospheric conditions, actuating automatic wiper control and dipper light control.

### 1. Introduction

Any sufficiently advanced technology is indistinguishable from magic” wrote Arthur C. Clarke. It is the embedded technology that makes all possible. Embedded systems help to drive cars with automatic wiper control and dipper light control. Remote control is also used to lock or unlock the door for security purpose. And the day is not far off when a car similar to what James bond drives comes in Embedded technology plays a key role not only in consumer electronics but in many safety-critical applications like avionics, space, railways and transport, process control and medicine. Embedded systems are usually single board computers (SBCS).These SBCS can be either embedded within a larger computer to manage a sub- system within the computer (such as flat-panel display boards, storage management systems or embedded web servers) or be the main solution like thin clients, wearable computers and internet appliances.

#### 1.1 Embedded Hardware

Due to the many applications of embedded systems, it is difficult to list all the different types of hardware used in them. Main hardware components of an embedded system are microprocessor / microcontrollers and supporting circuitry. The combination of a microcontrollers and its circuitry is application specific.

#### 1.2 Embedded Software

All the embedded software requirements can be broadly classified into Embedded Database, Embedded Language Extensions, Embedded Development Tools and Embedded Applications. Often the programs on an embedded system must run with real-time constraints with limited hardware resources: Often, there is no disk, operating system, keyboard or screen. A flash drive may replace the rotating media and a small keypad and LCD Screen may be used in place of a PC's keyboard and Screen. The firmware is the software embedded in hardware devices, e.g., ROM/ Flash memory chips. It is usually developed and tested for much stricter requirements than the general purpose software. Embedded system architectures need to be flexible enough to support the rapid evolution of security mechanisms and standards. Security requirements vary depending on the perspective being considered. The security model for each embedded system will dictate the combination of requirements that apply.

In most applications, a microcontroller can satisfy all the system requirements with no additional integrated circuits. Due to their low cost and a high degree of flexibility, microcontrollers are finding way into many applications that were previously accomplished by mechanical means or combinational logic. One such application is an automobile automation. Here's an automobile automation using PIC microcontroller 16F877A as well as AT89C2051. The software for the microcontroller is written in assembly language, which is capable of creating a hex file. The hex file code can be burnt into the microcontroller using any commonly available programmer or kit. IC 16F877A and AT89C2051 is a low power, high performance CMOS 8-bit microcontroller. It is manufactured using Atmel's high-density non-volatile memory technology and is compatible with the industry-standard 80C51 instruction set and pin out. The power full AT89C2051 microcontroller provides a highly flexible and cost-effective solution to many embedded control applications. Automobile automation comprises a handheld infrared transmitter, IR receiver / sensor, switching circuit, power supply, detection unit and alarm. The handheld IR transmitter has to be in the hand and the receiver module which remains fitted at a secure place in the car. A remote control handset is a transmitter unit which is for activating/deactivating the receiver unit, while directing the transmitter towards the sensor module such that the transmitted IR rays fall on it directly. The received signal activates the circuit to blow the horn, when an unauthorized person tries to gain access to the vehicle. In addition, sensors are used for automatic dipper light control and wiper control, so as to make the drive so safe and smooth (Fig.1).

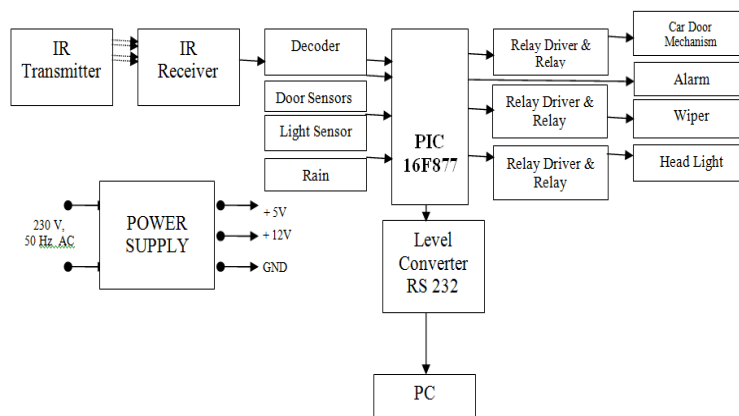

Fig.1: Block diagram for automobile automation

## 2. Block description

### 2.1. Power Supply

The power supply unit converts the 230V mains AC into 12V AC by using a transformer. The 12V AC is then rectified and filtered to get an unregulated supply of 12V DC. A regulator IC is used to get a regulated supply of about +5Volts and +12Volts. A mains switch is used to power the unit ON/OFF at user convenience.

### 2.2. IR Transmitter

The remote control is used as a IR transmitter which generates 38KHz IR rays and it is received by IR receiver module which is used for lock or unlock the car doors. This transmitter can be activated from up to 10 meters.

### 2.3. IR Receiver

IR receiver module uses TSOP1738 Sensor which is sensitive to the IR radiation modulated at 38 KHz. The output of this sensor is given as the input to the decoder.

### 2.4. Decoder

Microcontroller IC 89C2051 acts as a decoder. The decoded signal is given as input to the PIC 16F877A, which is used to lock or unlock the car door.

### 2.5. Door Sensor

This sensor is used to sense the door condition of the automobile whether it is in lock or unlock mode. Then this sensed signal is given as the input to the PIC 16F877A, which is used to activate / deactivate the alarm by comparing it with the decoded signal.

### 2.6. Light Sensor

LDR acts as a light sensor which is used to detect the light. The detected signal is given as the input to the PIC 16F877A, which is used to activate or deactivate the brightness of the light as per the input signal of the LDR.

### 2.7. Rain Sensor

This sensor is used to sense the rain water and the sensed signal is given as the input to the PIC 16F877A to control the wiper.

### 2.8. PIC 16F877A

The PIC 16F877A is a 40-pin 8-Bit CMOS FLASH Microcontroller. Its internal circuitry reduces the need for external components, thus reducing the cost and power consumption and enhancing the system reliability. Thus this microcontroller is programmed to receive the decoded signal from the remote control to lock or to unlock the door and this received signal is compared with the sensed door signal which is another input to this PIC microcontroller. If the sensed door signal is not matched with the decoded signal received from remote control, then the PIC 16F877A will activate the alarm. Simultaneously, the PIC microcontroller will receive the signals from the light sensor and rain sensor to activate the light brightness and the wiper through the relay driver and relay.

**2.9. Relay driver and relay:**

To turn ON/OFF the equipment and to lock / unlock the door locks relays are provided. Since the current driving capacity of the port pins of PIC 16F877A is not enough to drive the relays directly, transistors are used to boost the current to drive relays respectively.

**2.10. Alarm**

Alarms alert the owners that something has bumped into his car or some one has broken into it. If any of the car doors is kept open then automatically the alarm is activated, so that we come to know that one of the doors is in unlock condition.

**2.11. Level Converter RS 232**

IC MAX 232 is used as an RS-232 level converter. RS 232 standard is used for serial communication between two devices for speeds up to 115.2Kbs over distances up to 100 meters. Embedded systems are provided with communication interfaces for monitoring and control by a host systems or a node on a network. Through these interfaces, an embedded system can also be accessed over the internet (Fig. 2).

**2.12. Power supply unit**

Power supply circuit converts 230V mains AC into +12 Volts AC by using a transformer. This 12V AC is then rectified using diodes IN4007 and it is filtered by a capacitors. +12V unregulated voltage is regulated using regulator IC 7805 and IC 7812 to get a regulated voltage of +5V and +12V DC.

**2.13. Base unit**

The circuit diagram of a base unit in an Automobile Automation is shown in the figure. The system comprises Atmel’s AT89C2051 Microcontroller IC as a decoder and PIC 16F877A Microcontroller to control the entire processes of the System. The 38 KHz Infra Red (IR) rays generated by the remote control are received by IR receiver module TSOP1738 of the circuit. Pin 1 of TSOP1738 is connected to ground, Pin 2 is connected to the power supply through resistor and the output is taken from PIN 3. The output signal of the IR Sensor is decoded by the Microcontroller AT89C2051 which receives input through the Port P3.2 (Pin 6) and output the decoded signal through the Port P1.3 (Pin 15) and it is indicated through LED. The decoded signal is given as the input to the PortC1 (Pin 16) of PIC16F877A Microcontroller. The car doors sensor are given as the input to the PortB-RB1 (Pin 34), Port B- RB2 (Pin 35), PortB-RB3 (Pin 36) and PortB-RB4 (Pin 37) of PIC 16F877A Microcontroller. These signals are compared with the signals received from the remote control. If the signal received from the remote is (low) Lock mode, it is compared with the signals from car doors. If any of the car doors is unlock, then the output Port D (Pin 20) of PIC16F877A Microcontroller will activate the Alarm Circuit. The Port A (Pin 2) of PIC16F877A Microcontroller receives the signal from the LDR, which is used to detects the presence or absence of the light. If it detects the presence of light, then the output through the Port D (Pin 28) is activated by changing the relay contacts from normally open to normally closed contacts. Port A (Pin 3) of PIC 16F877A Microcontroller receives signals from the rain sensor. If the rain water falls on the sensor, then it gives low signal to the Port A (Pin 3) of PIC 16F877A Microcontroller and this signal activates the wiper through the relay contacts. Thus, the PIC 16F877A Microcontroller is programmed to control entire processes given above. These fully automated processes can also be monitored with the help of PC through the level converter RS232, a serial communication interface.

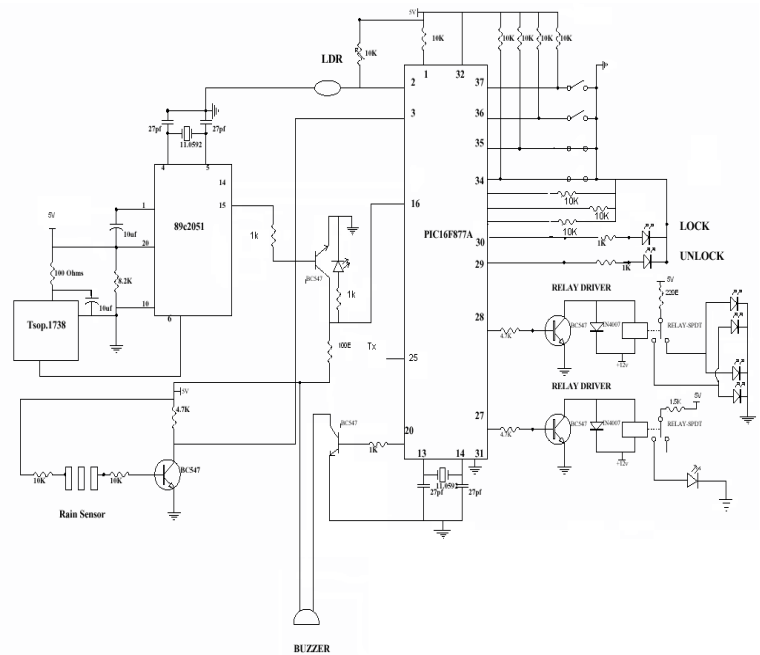

Fig.2: Circuit diagrams and its description

## 2.14. Serial Communication Interface Unit

PIC 16F877A is interfaced with RS232 connector through the MAX232 chip. The PIC 16F877A has two pins that are used specifically for transferring and receiving data serially. These two pins are called TXD and RXD and are part of the Port C. Pin-25 of the PIC is assigned as TXD and Pin-26 of the PIC is designated as RXD. These pins are TTL compatible. Therefore, they require a line driver to make them RS232 compatible. One such line driver is the MAX232 chip. Since the RS232 is not compatible with today's microprocessors and microcontrollers; a line driver is needed to convert the RS232's signals to TTL voltage levels. The MAX 232 converts from RS232 voltage levels to TTL voltage levels and vice versa. One advantage of the MAX232 chip is that it uses a +5V power source which is the same as the source voltage for the PIC16F877A.

The MAX232 has two sets of line drivers for transferring and receiving data. The line drivers used for TXD are called T1 and T2, while the line drivers for RXD are designated as R1 and R2. In this application only one of each is used. T2 and R2 are used together for TXD and RXD of the PIC and the second set is left unused. In MAX232 that the T2 line driver has a designation of T2IN and T2OUT on Pin Numbers 10 and 7, respectively. The T2IN Pin is the TTL side and is connected to TXD of the PIC, while T2OUT is the RS232 side that is connected to the RXD Pin of the RS232 connector. The R2 line driver has a designation of R2IN and R2OUT on Pin-8 and 9, respectively. The R2IN (Pin-8) is the TTL side that is connected to the RXD Pin of the microcontroller. MAX232 requires four capacitors of the value 0.1 $\mu$ f/50V.

## 3. Conclusion

Within a few years, all automobile functions will be 100 percent under the control of microcontroller. Safety, power transmission and entertainment are just a few of automobile functions that have transitioned from mechanical to electronic controls. Today, electronics devices and systems constitute well over \$1000 of an average vehicle's manufacturing cost and this figure is expected to increase rapidly. Modern-day automobiles are sophisticated, electronically controlled systems. To facilitate comfort and safety, while still being environment - friendly, these new machines are an amalgamation of the latest developments in mechanical, chemical, hydraulics, pneumatic and refrigeration technologies and last but not the least electronics. As electronics plays a crucial role in the operation of automobile systems, an understanding of this key technology is a must for the industry. Apart from mastering the mechanical skills involved in repair of faulty and damaged components, engineers and technicians must be able to diagnose and service related electronics systems. Electronics devices, microcontrollers, sensors, computers, etc., are being incorporated to control the engine and its subsystem because of these controls, cars consume less fuel, function better and operate cleaner.

### 3.1. Advantages

Automobiles with electronic components and systems run much faster than their mechanical, hydraulic, and pneumatically counterparts. Electronics- based or electronics-controlled systems can be monitored and their mode of operation can be changed very quickly. Since electronic components don't have moving parts, these are light, don't wear easily, last longer, and don't require periodic adjustments. The future use of electronics in automobiles is limited only by the creativity of designers. This creativity will shape the vehicles of the future. The use of electronics is also influenced by other non-technical factors. Legislation is one of the main factors. Automobile manufacturers are responding to laws stipulating safer and cleaner cars. On-board diagnostic laws have been passed abroad, requiring vehicle manufacturers to use common standard systems and terminologies. This will facilitate easier and better repair and servicing of computer controls used in automobiles. Hitherto, each manufacturer followed their own approach to computer controls, resulting in as many different systems as there were car models.

### 3.2. Applications

Embedded systems help drive cars giving directions to follow, entertaining through journey, keeping us connected with anyone across the globe and even warning us of potential dangers.

### 3.3. Future technologies

Automobile technology is one of the fastest growing fields and it is no longer restricted to mechanical engineering. Advances in this field are based on simultaneous coordination between a multitude of inter - related technologies. Automobile engineer's today need to be conversant with mechanical / electrical / electronics aspects, material sciences, processors and related software, telemetry and telecommunication techniques. Also, there is dire need for constant updating and exposure to remain in touch with the global trends and developments. There is a possible scope of incorporating suitable built-in software to cater to tracking the path of a car under varies traffic and visibility conditions. Developments in automatic car control mechanism can enable easy negotiation of live traffic. Car automation and control is an area where development work is in progress round the globe. User-friendly features are gradually being incorporated in various models. Drivers will be able to negotiate difficult traffic situations at the touch of a button. Independent research activities are concurrently in progress.

## References

1. Muhammad Ali Mazidi & Janice Gillispie Mazidi (2000). "The 8051 Microcontroller and Embedded System", Pearson Education.



2. Raj Kamal (2003) Embedded systems - Architecture, Programming and Design”, Tata McGraw-Hill.
3. John B. Peatman (1997) Design with PIC Microcontroller, Hardcover.
4. Janathan. W. Valvano (2001) Embedded Micro Computer System, Real time Interfacing, Thomson Learning.
5. Wayne Wolf (2001) Computer Components-Principles of Embedded Computing System design”, Morgan Kaufmann.
6. Prasad, KVKK. (2004). Embedded / Real –Time Systems: Concepts, Design and Programming”, Dream tech Press.