

# Basic Compensation Principle and Reference Current Generation

T. Saravanan<sup>1\*</sup>, V. Srinivasan<sup>1</sup> and G. Saritha<sup>2</sup>

<sup>1</sup>Department of ETC, Bharath University, Chennai-600073, Tamil Nadu, India; saravanan.etc@bharathuniv.ac.in, sriniraj99@gmail.com

<sup>2</sup>Sairam Institute of Technology, Chennai-600044, Tamil Nadu, India.

## Abstract

Reactive power compensation is an important aspect in the control of distribution systems. Reactive current in addition to increasing the distribution system losses, introduces various power quality problems like, harmonics, voltage sag, swell and poor load power factor. These power quality issues result in the malfunction of sensitive equipments. A Distribution Static Compensator (DSTATCOM) proves to be a viable solution for the mitigation of such power quality issues. The aim of this paper is to compare an optimized PI and a Fuzzy controlled DSTATCOM for reactive power compensation and harmonic mitigation. Here the PI controllers are first optimized by using error minimization criteria through Genetic algorithms and then replaced by a Fuzzy controller. Through various simulations it is concluded that the transient response of fuzzy controllers is better than the optimized PI controllers

**Keywords:** Decoupled Current Control, Distribution Static Compensator (DSTATCOM), Fuzzy Logic Controllers, Genetic Algorithms, Integral Square Error (ISE), Power Quality

## 1. Introduction

Distribution Static Compensator (DSTATCOM) is an important shunt compensator which has the potential to solve many power quality problems faced by distribution systems<sup>1,2</sup>. DSTATCOM has effectively replaced a Static Var Compensator (SVC), as the latter possesses a larger response time in addition to being supplemented with passive filter banks and offering only steady state reactive power compensation. A DSTATCOM is basically a Voltage Source Converter (VSC) based FACTS controller sharing many similar concepts with that of a STATCOM used at transmission level<sup>3</sup>. A STATCOM at the transmission level handles only fundamental reactive power and provides voltage support while as a DSTATCOM is employed at the distribution level or at the load end for load compensation. Additionally, a DSTATCOM can also behave as a shunt active filter<sup>4,5</sup>, to

eliminate unbalance or distortions in the source current or the supply voltage as per the IEEE-519 standard limits. Since a DSTATCOM is such a multifunctional device, the main objective of any control scheme should be to make it flexible and easy to implement in addition to exploiting its multi functionality to the maximum. In this paper control scheme is based on decoupled current control where the DSTATCOM is treated as a reactive current source. Conventionally, Proportional Integral (PI) controllers have been used for the regulation of ac/dc voltage loops to generate decoupled reference current templates. The PI controllers require exact mathematical models, which are difficult to evaluate and are stringent to any sought of parameter variations, nonlinearity and load disturbance etc. Here, PI controller is optimized offline incorporating Genetic Algorithms to tune its parameters relative to a performance index (ISE)<sup>6</sup>. The transfer function of the controller is obtained by small signal

\*Author for correspondence

perturbation technique. Fuzzy controllers have been employed in STATCOM at transmission level, to enhance interconnected power system stability<sup>7,8</sup>. Fuzzy controlled STATCOM has also been dealt with in<sup>9,10</sup> at low voltages. The main advantage of Fuzzy controllers is that they allow for a simpler more human approach to control design and do not demand the mathematical modeling knowledge of traditional control design methods.

The Fuzzy controller incorporates scaled versions of reference dc link voltage and the sensed dc voltage, which are assigned seven linguistic fuzzy variables. The rule base is formulated on the general dynamic behavior of a typical closed loop system.

The DSTATCOM is simulated using MATLAB/Simulink power system blockset and the controllers are made using Genetic Algorithm Optimization Toolbox (GAOT) toolbox<sup>11</sup> and Fuzzy logic toolbox. Computer simulations highlight the superiority of Fuzzy controllers over optimized PI Controllers.

## 2. Basic Compensation Principle and Reference Current Generation

A DSTATCOM considered here is a controlled reactive source which includes a Voltage Source Converter (VSC) and a DC link capacitor connected in shunt, capable of generating and /or absorbing reactive power. The reactive power control in a DSTATCOM can be employed to either achieve a unity power factor operation by compensating for reactive power demand of the connected load, or to regulate the voltage by compensating for the losses of the distribution lines. These two operations cannot be performed simultaneously<sup>12</sup>. Appropriate performance can be achieved by independent control of the decoupled currents,  $I_d$  and  $I_q$ <sup>13</sup>. The controller as shown in Figure 1, comprises of an outer loop consisting of ac and DC voltage controllers and an inner current controller. Three phase ac supply voltages and dc link voltages are sensed and converted into their per unit values and fed to two PI controllers, the outputs of which decide the amplitude of the reference reactive and active current to be generated by the DSTATCOM. The AC voltage loop is activated in order to achieve voltage regulation. The current  $I_q^*$  is the output of a PI controller, the input to which is the deviation of the PCC voltage  $V_{pcc}$  as compared to a reference  $V_{pcc}^*$ . The current  $I_q^*$  is assigned zero during unity power factor operation and harmonic mitigation<sup>1-5</sup>.

The DC voltage loop is responsible for keeping constant the DC voltage through a small active power exchange with the ac network compensating the active power losses in the filter and the inverter. The output of this PI controller is  $I_d^*$ , input to which is the deviation of  $V_{dc}$  from  $V_{dc}^*$ . The current  $I_d^*$  is responsible for unity power factor and harmonic mitigation operation in a DSTATCOM.

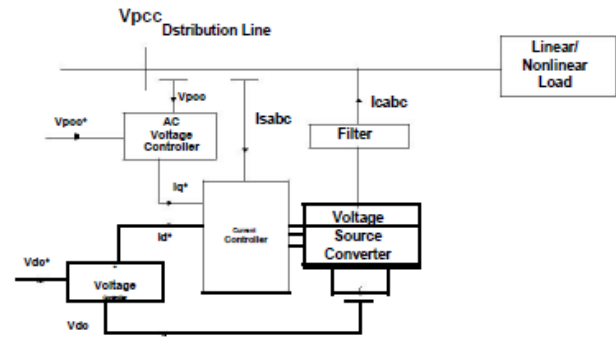


Figure 1. Indirect Control of DSTATCOM.

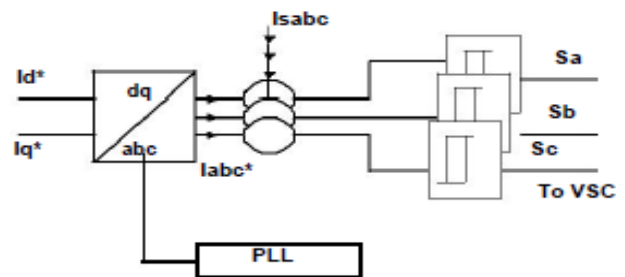


Figure 2. DSTATCOM current controller.

The inner loop current controller as shown in Figure 2 gives switching commands to the VSC. The direct and the quadrature reference currents obtained from the outer loop are transformed into abc frame by dq\_abc transformations. A Phase Locked Loop (PLL) is used to synchronize the control loop to the ac supply so as to operate the dq\_abc reference frame. The transformed abc reference currents and the sensed line currents are fed to the inner loop current controller which is a carrier less hysteresis controller.

The switching is obtained as:

If  $I_{sa} > (I_{sa}^* + h)$ , upper switch of inverter leg corresponding to phase 'a' is ON and the lower switch is OFF.

If  $I_{sa} < (I_{sa}^* - h)$ , upper switch of inverter leg corresponding to phase 'a' is OFF and the lower switch is ON.

Similarly the switching state of the other phases is calculated and the three currents are regulated within the assigned tolerance band 'h' of their respective values. The tracking becomes better if the hysteresis band is narrower, but then the switching frequency is increased which results in increased switching losses. Therefore the choice of the hysteresis band should be a compromise between the tracking error and the inverter losses. The main advantage of tracking control is that it is simple, robust and exhibits an automatic current limiting capability<sup>6-10</sup>.

### 3. Implementation of Dc Voltage Loop

As observed in the above section the DC loop of the DSTATCOM operates in order to regulate the DC link voltage to the desired level. The output of the PI controller decides the amplitude of the in phase reference signal, which is compared with the source current and the error drives the hysteresis controller for gate pulse generation. In this manner complete reactive power compensation and harmonic mitigation is achieved in a DSTATCOM. The DC voltage loop is implemented with the following controllers in order to reduce the steady state error.

#### 3.1 Optimized Pi Controller

Figure 3 shows the block diagram of the DC voltage control loop where, G1 is the transfer function of the PWM converter.

G2 is the gain of the PI controller

The transfer function of the PWM converter at a particular operating point in steady state is obtained by equating the average rate of change of energy associated between the input (ac link) and output (dc link) [7], when the PCC voltage is assumed to be regulated stable. The transfer function for a steady state operating point is given as:

$$G1(s) = \frac{\Delta V_{dc}}{\Delta Id} = \frac{3V_t/2}{2V_{dc}/R + sCV_{dc}}$$

C, V<sub>dc</sub> are the dc side capacitor and its voltage

V<sub>t</sub> is the ac side voltage at the PCC

The values of the above parameters are mentioned in appendix 1.

The gain of the PI controller is given as:

$$G2(s) = K_p + \frac{K_i}{s} \quad \text{where}$$

K<sub>p</sub> = proportional gain which determines the voltage response.

K<sub>i</sub> = integral gain which defines the damping factor of the loop.

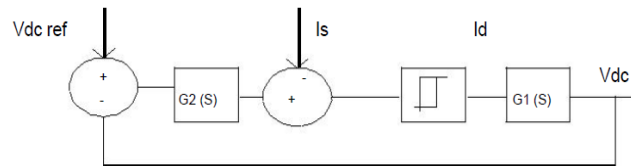


Figure 3. Block Diagram of DSTATCOM voltage control loop

Here genetic algorithms are used offline to optimize the PI parameters of the DC voltage loop, based on a fitness function and the search procedure is such that the performance index is minimized. The performance index chosen is Integral Square Error (ISE), which is given as:

$$ISE = \int_0^t (V_{dcref} - V_{dcact})^2 dt$$

and the fitness is calculated as the inverse of the Integral Square Error which is evaluated using GAOT toolbox, GA's basically start with an initial population containing a number of chromosomes, whose performance is evaluated using the fitness function. The algorithm is repeated for many generations, the offspring being improved with each generation by the use of genetic operators and finally terminates when reaching at the individual, which is the optimum solution to the problem. The optimized values of K<sub>p</sub> and K<sub>i</sub> corresponding to the minimum performance index are found to be 29.96 and 40.12 respectively<sup>11-15</sup>.

#### 3.2 Fuzzy Controller

As observed in the previous section the control loop consists of a typical PI controller whose parameters are obtained by first deriving the transfer function of the system and then simplifying it by incorporating small signal disturbances to the system and linearizing at the common operating point. The major disadvantage of the conventional controllers is, different sets of PI controller parameters are required with different kinds of loads and thus every time the parameters need to be optimized.

Here the superiority of fuzzy logic controllers results in the effective management of the nonlinear behavior of both the controllers, taking the advantage of heuristics and expert knowledge of the process being controlled. The advantages of Fuzzy Logic Controllers over the conventional PI controllers are that they do not need an accurate mathematical model, they can work with imprecise inputs, can handle nonlinearity, and are more robust than the conventional PI controllers<sup>16</sup>.

The actual inputs to the controller are scaled versions of reference dc link voltage  $V_{dc}^*$  and the sensed dc voltage  $V_{dc}$ , and the output is the reference current  $I_d^*$ . Each of the fuzzy input signals and output signals are fuzzy variables and are assigned seven linguistic variables. The difference of reference dc link voltage and the actual voltage is given as  $E_1$ , where as  $E_2$  is its incremental variation and are given by,

$$E_1 = V_{dc}^* - V_{dc}$$

$$E_2 = E_1(n) - E_1(n-1)$$

Where  $E_{1(n)}$  is equal to  $E_1$  at the  $n^{th}$  sampling instant and  $E_{1(n-1)}$  is equal to  $E_1$  at the  $(n-1)^{th}$  sampling instant. The output of the controller is denoted as  $I_d^*$ . A limit is put on the output of the controllers in

order to have proper dc voltage control.

The rule base formulation is based on the general dynamic behaviour of the process which is a closed loop system<sup>14</sup> The seven uniformly distributed triangle membership functions for each input leads to  $7 \times 7 = 49$  rules as shown in Table 1.

**Table 1**

E1/E2	NB	NM	NS	ZE	PS	PM	PB
NB	NB	NB	NB	NB	NM	NS	ZE
NM	NB	NB	NB	NM	NS	ZE	PS
NS	NB	NB	NM	NS	ZE	PS	PM
ZE	NB	NM	NS	ZE	PS	PM	PB
PS	NM	NS	ZE	PS	PM	PB	PB
PM	NS	ZE	PS	PM	PB	PB	PB
PB	ZE	PS	PM	PB	PB	PB	PB

## 4. Simulation Results

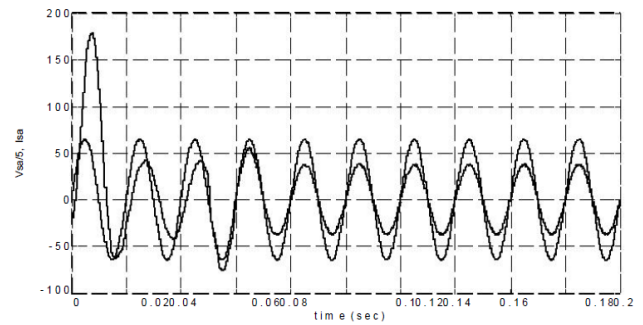
The comparison of controllers is carried out by computer simulations using MATLAB/Simulink/Power System Blockset. The parameters of the system are mentioned in

Appendix I.<sup>17</sup> The comparison of optimized PI and Fuzzy Controlled DSTATCOM is carried out on the

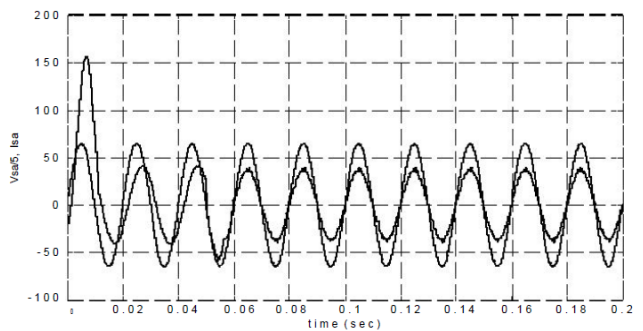
basis of power factor correction, harmonic mitigation considering the following cases:

### 4.1 Switch on and load perturbation response for a linearly varying load.

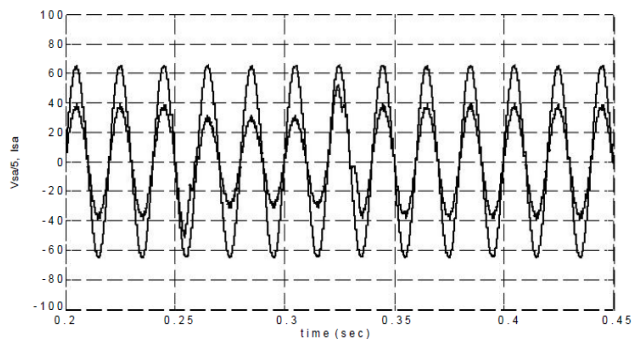
The performance of both the controllers during switch on is shown in Figure 4 and Figure 5 respectively, when the DSTATCOM is turned on at 0.05secs. it can be observed that the source current settles down faster in case of a



**Figure 4.** Source voltage and current when the compensator is turned on at 0.05 secs.(PI Controller)

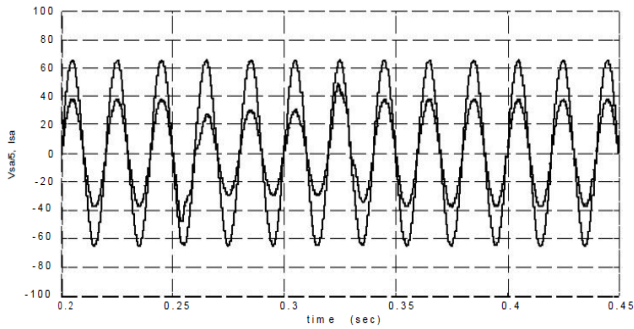


**Figure 5.** Source voltage and current when the compensator is turned on at 0.05 secs.(Fuzzy Controller)



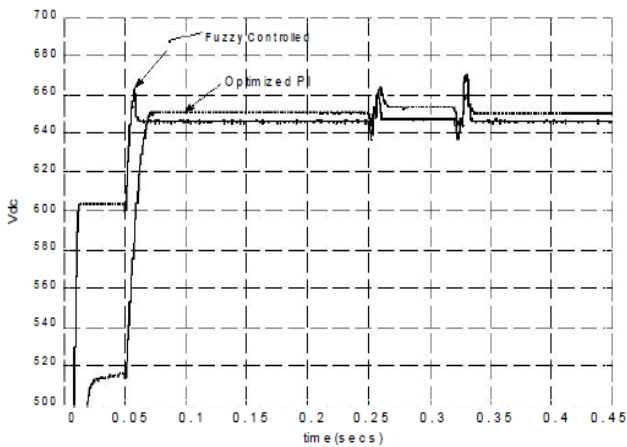
**Figure 6.** Source voltage and current when the load is reduced by 22% from 0.25-0.32secs.(PI Controller)

fuzzy controlled DSTATCOM. Load perturbation is applied by suddenly reducing the load by 22% between 0.25-0.32 secs. The source current variation for PI and Fuzzy Controlled DSTATCOM is shown in Figure 6 and Figure 7 respectively



**Figure 7.** Source voltage and current when the load is reduced by 22% from 0.25-0.32secs.(Fuzzy Controller)

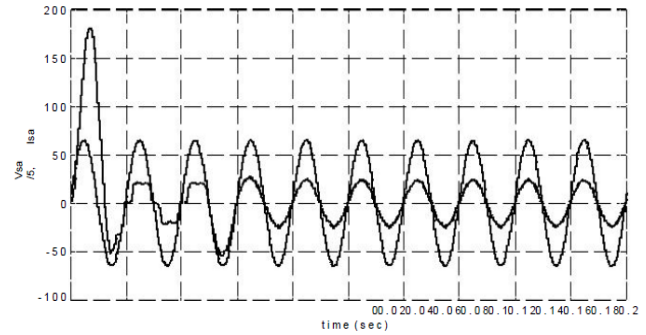
The performance of DC Capacitor voltage regulation considering switch on response and load perturbation for the controllers is shown in figure8, though the overshoot is slightly larger using a Fuzzy Controller, the rise time and the settling time are much less than the PI Controlled DSTATCOM. The comparison in terms of settling time of DC link voltage during switch on and load perturbation is shown in table III.



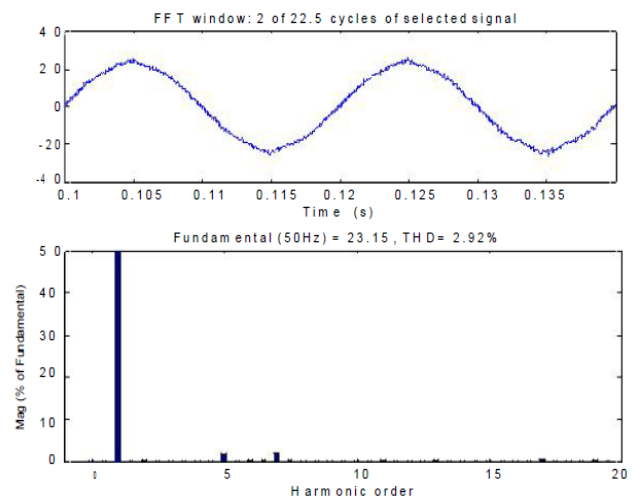
**Figure 8.** DC Link voltage variation for during switch on and load variation

### 4.2 Switch on and load perturbation response for a non linearly varying load.

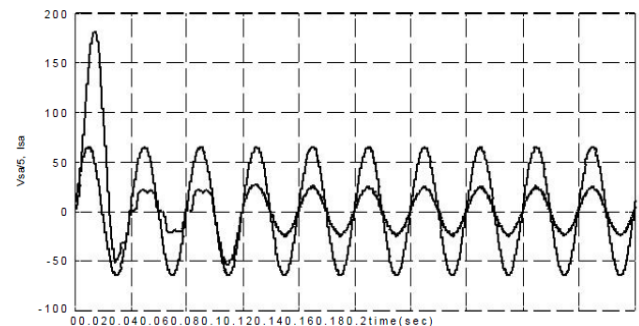
The THD of the uncompensated nonlinear source current is reduced from 21.21% to 2.92% when the optimized



**Figure 9.** Source voltage and current when the compensator is turned on at 0.05 secs.(PI Controller)



**Figure 10.** THD in source current (PI Controller)



**Figure 11.** Source voltage and current when the compensator is turned on at 0.05 secs.(Fuzzy Controller)

PI controlled DSTATCOM is turned on at 0.05secs. as shown in figures 9 and 10. Figures 11 and 12 shows that the THD after compensation reduces to 1.64% with a

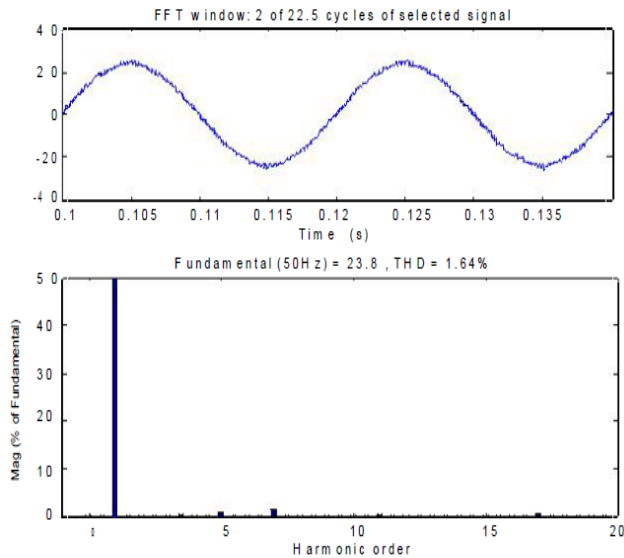


Fig.12. THD in source current (Fuzzy Controller)

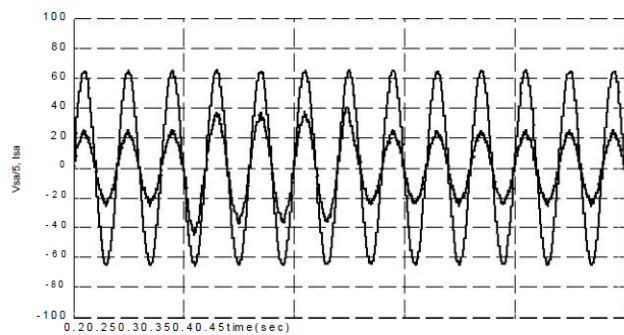


Figure 13. Source current when the load is suddenly changed from 0.25-0.32 secs.(PI Controller)

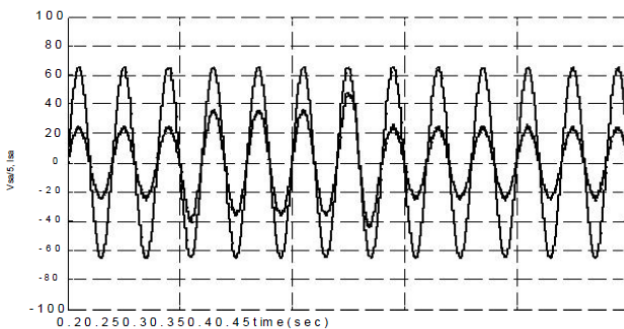


Figure 14. Source current when the load is suddenly changed from 0.25-0.32 secs.(Fuzzy Controller)

fuzzy controlled DSTATCOM and the settling time is also less<sup>18</sup>. These results are tabulated in Table III.

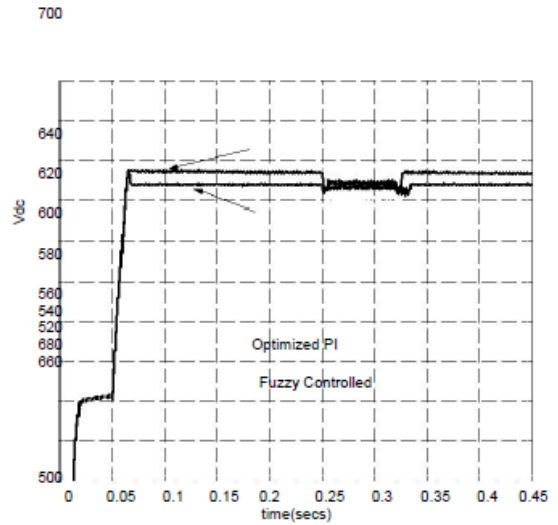


Figure 15. DC Link voltage variation for during switch on and load variation

Load perturbation is applied by suddenly increasing the nonlinear load between 0.25-0.32 secs.. Figures 13 and 14 show the source current variation of a PI and Fuzzy Controlled DSTATCOM respectively and their THD are compared in Table 3.

The performance of the reference dc link voltage regulation during switch on and load perturbation for the controllers is shown in Figure 15<sup>19, 20</sup>. The response of a fuzzy controller during switch on and load perturbation is faster as compared to a PI controlled DSTATCOM, as described in table 3.

Table 3

	Variation in Load		Settling Time		% THD	
			PI	Fuzzy	PI	Fuzzy
<b>I</b>	<b>Switch on Response</b>					
	(i) Linearly varying load		26msec	10msecs	-	-
	(ii) Nonlinearly varying load		22msec	15msecs	2.92	1.64
<b>II Load perturbation response</b>						
(i) Linearly varying load			15msec	10msec	-	-
(ii) Nonlinearly varying load			6msec	6msec	2.78	2.28

## 5. Conclusion

A fuzzy controlled DSTATCOM has been found effective under different applications such as, reactive power compensation, harmonic mitigation, thus enhancing power quality. The performance of the fuzzy controller is compared with the optimized PI controller by digital computer simulations. The optimization of the fuzzy matrix is done from the experience of PI controller behaviour, Genetic Algorithms can also be used for its optimization. It can be concluded that the transient response of fuzzy controllers is better than the optimized PI controllers.

APPENDIX I. SYSTEM PARAMETERS	
Supply Voltage (Vs)	400V (L-L)
Source impedance(X/R=6)	$L_s=1.9e-3H, R_s=0.1ohms$
Fundamental Frequency	50Hz
Filter Impedance	$L_c=4.5e-3H, R_c=0.2ohms$
DC Capacitance (Cdc)	3000 $\mu$ F
DC Link Voltage (Vdc)	650V
Load	22KVA at 0.83 lagging
Non Linear Load	$R_1=30ohms, L_1=20e-3$
	$R_2=18ohms, L_2=7.5e-3$

## 6. References

- Gygui L. Dynamic compensation of AC transmission lines by solid state synchronous voltage sources. IEEE Transactions on Power Delivery. 1994; 9(2):904–11.
- Deng Yongan, Sood VK, Lopes L. STATCOM model in EMTF EV using Hysteresis current controlled Voltage Source Converter (VSC). IEEE Canadian Conference on Electrical and Computer Engineering; 2005. p. 517–22.
- Kumaravel A, Meetei ON. An application of non-uniform cellular automata for efficient cryptography. Indian Journal of Science and Technology. 2013; 6(S5):4560–6. ISSN: 0974-6846.
- Mak LO, Ni YX, Shen CM. STATCOM with Fuzzy controllers for interconnected power systems. Electric Power Systems Research. 2000; 55: 87–5.
- Singh BN, Chandra, Haddad K Al. DSP based indirect current controlled STATCOM, Part 1: Evaluation of Current Control Techniques. IEEE Proceedings Electric Power Applications; 2000 March; 147(2):107–12.
- Kumaravel A, Pradeepa R. Efficient molecule reduction for drug design by intelligent search methods. International Journal of Pharma and Bio Sciences. 2013; 4(2):B1023–9. ISSN: 0975-6299.
- Singh BN, Chandra, Haddad K Al. DSP based indirect current controlled STATCOM, Part 2: Multifunctional Capabilities. IEEE Proceedings Electric Power Applications; 2000 March; 147(2):113–8.
- Houck C, Joines J, Kay M. A Genetic algorithm toolbox for function optimization: A Matlab implementation. NCSU-IE TR. 1995.p. 95–05.
- Kumaravel A, Pradeepa R. Layered approach for predicting protein subcellular localization in yeast microarray data. Indian Journal of Science and Technology. 2013; 6(S5):4567–71. ISSN: 0974-6846.
- Miller T H E. Reactive power control in electric systems. John Wiley and Sons; 1982.
- Sen KK. STATCOM-Theory, Modeling and Applications. IEEE-C Proceedings Power Energy Society; 1998. p. 1177–83.
- Jain SK, Agarawal P, Gupta HO. Fuzzy logic controlled shunt active filter for power quality improvement. IEEE Proceedings Electr. Power Appl; 2002; 149(5):317–28.
- Srinivasan V, Saravanan T. Analysis of harmonic at educational division using C.A. 8332. Middle-East Journal of Scientific Research. 2013; 16(12); 1768–73. ISSN: 1990-9233.
- Srinivasan V, Saravanan T. Reformation and Market Design of Power Sector. Middle-East Journal of Scientific Research. 2013; 16(12):1763–7. ISSN: 1990-9233.
- Kumaravel A. Udhayakumarapandian D. Construction of meta classifiers for apple scab infections. International Journal of Pharma and Bio Sciences. 2013; 4(4):B1207–13.
- Srinivasan V, Saravanan T, Udayakumar R. Specific absorption rate in the cell phone user's head. Middle-East Journal of Scientific Research. 2013; 16(12):1748–50. ISSN: 1990-9233.
- Saravanan T, Udayakumar R. Comparison of different digital image watermarking techniques. Middle-East Journal of Scientific Research. 2013; 15(12):1684–90. ISSN: 1990-9233.
- Lydia Caroline M, Vasudevan S. Growth and characterization of pure and doped bis thiourea zinc acetate: Semiorganic nonlinear optical single crystals. Current Applied Physics. 2009; 9(5):1054–61.
- Saravanan T, Udayakumar R. Optimization of Machining Hybrid Metal matrix Composites using desirability analysis. Middle-East Journal of Scientific Research. 2013; 15(12):1691–7.
- Saravanan T, Udayakumar R. Simulation Based line balancing of a single piece flow line. Middle-East Journal of Scientific Research. 2013; 15(12):1698–701. ISSN: 1990-9233.
- Kimio T, Natarajan G, Hideki A, Taichi K, Nanao K. Higher involvement of subtelomere regions for chromosome rearrangements in leukemia and lymphoma and in

- irradiated leukemic cell line. *Indian Journal of Science and Technology*. 2012 April; 5(1):1801–11.
22. Cunningham CH. *A Laboratory Guide in Virology*. 6th ed. Minnesota: Burgess Publication Company; 1973.
  23. Sathish Kumar E, Varatharajan M. Microbiology of Indian Desert. In: Sen DN, editor. *Ecology and Vegetation of Indian Desert*. India: Agro Botanical Publishers; 1990. p. 83–105.
  24. Varatharajan M, Rao BS, Anjaria KB, Unny VKP, Thyagarajan S. Radiotoxicity of Sulfur-35. *Proceedings of 10th NSRP; India*. 1993. p. 257–8.
  25. 01 Jan 2015. Available from: <http://www.indjst.org/index.php/vision>