

# A Method of Reducing the Tillage Energy Intensity of Rotary Hillers using Adaptive Working Members with a Convertible Cutting Angle

Vladimir F. Kupryashkin\*, Nikolay I. Naumkin, Aleksei S. Knyazkov, Michail N. Chatkin and Nikolay P. Pyatkin

Ogarev Mordovia State University, Saransk - 430005, Russia; kupwf@mail.ru

## Abstract

The energy intensity of soil cutting by rotary hillers has been analyzed and the conclusion has been made about the necessity to keep the constant cutting angle of rotary hiller knives for reducing energy intensity. The analysis of the existing designs of rotary hillers has shown that they provide the constant angle, but only for one operating mode of a rotary hiller. We propose a method of energy intensity reduction by providing the constant cutting angle throughout the range of rotary hillers operating modes and the device for its implementation. Preliminary tests of the proposed design confirmed the declared requirements, which we made for modern working members (adaptation to changes of environmental conditions, providing the required quality of soil cultivation, the stability of working unit, reducing energy intensity while increasing productivity and others).

**Keywords:** Cutter of Rotary Hiller, Cutting Angle, Energy Intensity, Profiling, Rotary Hillers, Synthesis

## 1. Introduction

Currently, in agriculture, rotary hillers of different designs are widely used to crumble the soil more intensively, to weed out and to reduce plant residues, to mix up soil layers, to carry put field leveling and other technological operations<sup>1-6</sup>. Milling is one of the ways to cultivate the soil; this process is rather energy intensive and exceeds energy intensity of tillage by other equipment<sup>4,7-10</sup>. In this regard, it is more reasonable to mill heavy soil where it is necessary to reduce soil monoliths strongly and where tools with passive working members (ploughshare) do not guarantee the required quality of their operation. In this article, based on the analysis of well-known and our own researches, we propose a new way to raise efficiency of rotary hillers as exemplified by self-propelled compact rotary hillers, owing to a significant decrease of energy intensity by means of keeping a constant cutting angle

depending on changing environmental conditions and cutting modes.

## 2. Concept Headings

During milling soil by self-propelled compact rotary hillers, a large part of energy is spent on rolling running wheels (grousers) and on the work of the tine rotor<sup>11-15</sup>. Less quantity of energy is spent on the friction in transmission. There are flutes on many self-propelled compact rotary hillers, which also make extra friction on the bottom of the cart track. In comparison with the first two factors, friction on the cart track bottom is insignificant, that is why we could neglect it in our calculations. And the power, consumed for tine rotor operation, includes power used on cutting, destroying and interleaving of soil and power for throwing off soil by

\* Author for correspondence

a side of cutter. For self-propelled compact rotary hillers, the rotation of horizontal tine rotor is directed clockwise as a result of horizontal pushing, rotor hiller power appears as a constituent of soil reaction on the working members. Taking the above-mentioned for determinant operation mode of self-propelled compact rotary hillers, energy intensity of soil cultivation can be shown by the following formula<sup>16-18</sup>:

$$E = E_1 - E_2 + E_3 + E_4 + E_5, \quad (1)$$

where  $E_1$  – energy intensity of rolling running wheels of self-propelled compact rotary hillers;  $E_2$  – energy intensity of pushing rotary hiller;  $E_3$  – energy intensity of soil cutting;  $E_4$  – energy intensity of throwing off soil by cutters;  $E_5$  – energy intensity which is spent on the friction in transition.

Therefore the efforts aimed at decreasing one of these components, can provide the decrease of energy intensity. However, the main assignment of self-propelled compact rotary hillers is tillage and that is why the main rate of energy is connected with cutting and first of all, the attention will be focused on decreasing this component of energy intensity.

There are many forms of cutters which are used in the devices like tine rotor and L-shaped cutters<sup>4,6,17</sup> are most widely used, but the most optional disposition is a closed spiral on tine rotor of width rotary hillers<sup>12</sup> and oncoming spirals with symmetric position in self-propelled compact rotary hillers, that is why the following arguments will be conducted to it.

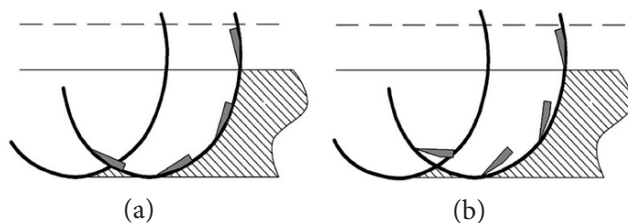

**Figure 1.** Trajectory of cutter motion

Extensive researches of tillage energy intensity by rotary hillers were made by G.F. Popov<sup>19</sup>, in which it was confirmed that rotary hiller energy intensity could be decreased, if the constant cutting angle is provided. During the operation of this tine rotor (Figure 1a) each cutter moves along the trochoidal trajectories with the minimal angle of deflection. During this process we can see the minimal resistance of soil by the cutter. Cutter

motion (Figure 1b), in the typical tine rotor, is carried out with changes of cutter angle, that is why the additional cutting resistance appears accompanying additional soil crush and mixing it to free cart track. This increases energy consumption for cutting.

Therefore, the most important aim is to provide the constant cutting angle by using special technical decision. Our patent search<sup>20-22</sup> have shown that there are equipments as patents for the invention and utility models as shown in Table 1.

The disadvantages of these devices are providing the required cutting angle only for one operating mode and manual change of this angle, which requires stopping a rotary hiller. The latter disadvantage was eliminated in the design rotor design by G. F. Popov<sup>19</sup>, which consists (Figure 2) of section of tine rotor 1, on which there are shanks 2 of cutters 3. The shank 2 is made in the shape of connecting rod, on the one end of which cutters 3 are installed and the other end is connected with fixed cam 4. During the operation, the cylinder 1 rolls and makes translational motion together with the entire rotary hiller. Because of the cutter shank 3 by the short ends run in by rollers 5 along cam 4, it makes additional curvilinear motion. Combination of the last one with rolling movement of cutters 3 together with tine rotor 1 provides the constant cutting angle for any mode of position of rotary hillers.

The design provides the constant cutting angle, which removes the extra capacity on friction; the required quality of tillage for milling; effective cutting of weed rhizomes and removes scattering and dispersion of soil during the whole cutting process.

Laboratory tests of this device have shown that the constant cutting angle is provided by decreasing power, approximately by 30% in comparison with an ordinary design of rotary hiller.

Disadvantage of this design is in provision of the constant cutting angle only in one calculated kinetic mode. During the changes of the translational speed of the rotary hiller, which could be necessary when soil characteristics change, the cutting angle ceases to be constant, due to increasing speed, friction appears on the back part of the cutter against uncultivated soil, but decrease in speed results in friction of the front part of the cutter, which enhances the energy intensity of cutting.

As a result, the authors suggest the rotary hiller which provides the constant cutting angle along all range of changes of its translational speed<sup>23</sup> caused by physical and

**Table 1.** Results of patent search

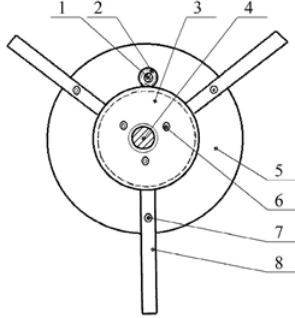
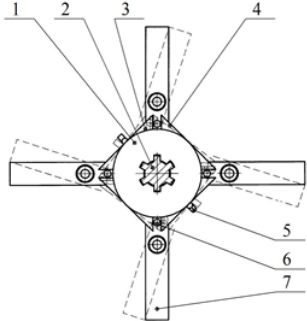
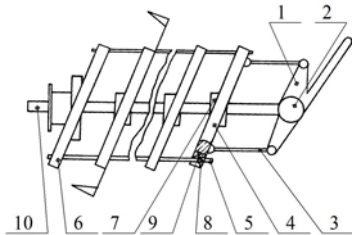
No	Scheme of device
1	
2	
3	

**Operating principle**

The device operates in the following way. An effort is passed by the worm gear of an additional shaft 1 and gear wheel 2 to regulate gear wheel 3. It turns relatively the main shaft 4 and accordingly to bearing disk 5 for the required angle. As bolts 6 are inflexibly fixed on regulative gear wheel 3, and in cutter holes 7 they are not fixed, then they push the cutter ends 7 bringing them to move accordingly to bolts 8, that is why it changes an attack of cutter angle.<sup>20</sup>

The device operates in the following way. The motion of removable disks 1 along the shaft 2, the position of plates 3 is changed, as a result, washer 4 turns accordingly to shaft 2 due to shank 5, repeated changes of whole positions in figural plates 3. Washer pivoting 4 puts in motion bolts 6, which turn cutters 7 to the required angle to bearing disks, connected with cutters 7.<sup>21</sup>

The device operates in the following way. An effort through arm 1 passes to rocker 2. This effort changes reciprocal position of drafts 3, connected with a ring of disk 4. Drafts 5 connect with disks 4 and 6 between themselves. And at the same time on the middle rings 7 constantly move outside rings 8 on bolts 9. The device of changing attack angle of cutters connects with middle ring 7 of following disk, placed on opposite end of axle 10 accordingly to driving disk 6.<sup>22</sup>

mechanical features of soil (Figure 3).

The device contains the main shaft 1, with fixed planet carrier 2 on it, with axles 3, where connecting rods 4 are installed floatingly, there are 5 cutters on the long arm and the short arm has moving rollers 6, which roll conical cam 7, installed on the case 8 with the possibility of executing the linear movement using a carrier 9 with an arm 10.

The device works in following way. The main shaft 1 is moving with the carrier 2 with axles 3 and connecting rods 4 with cutters 5 and conical cam 6 installed on it. During the rolling of mechanism, conical roller 6 affects cam 7, turning connecting rods 4 with cutters 5 around axle 3; this provides the constant cutting angle. This angle continues to be constant only for a determined surface section of cam 7 according to the onward speed of a hiller. When we increase the speed, cam 7 starts to move longitudinally on case 8 due to carrier 9 with a fixed arm 10 towards the decrease of lateral surface of a cam

section, relatively to conical rollers 7, but during the speed decrease, it happens the other way, then rollers 6 exert impact on the other section of a cam profile, providing the constant cutting angle.

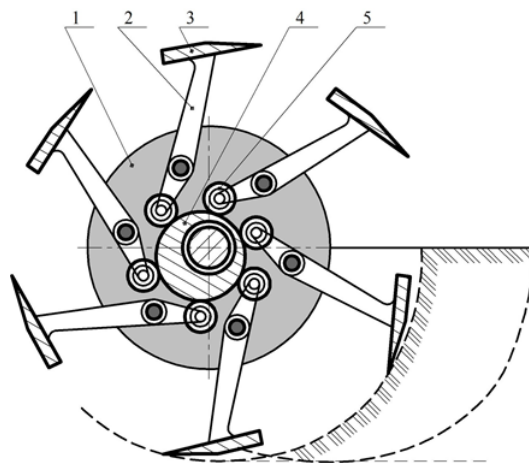

**Figure 2.** Rotary hiller with the constant cutting angle.

This kind of design provides the activation of the required law of motion of rotary hiller cutters in changing environmental conditions, in comparison with simple and compact design of the device.

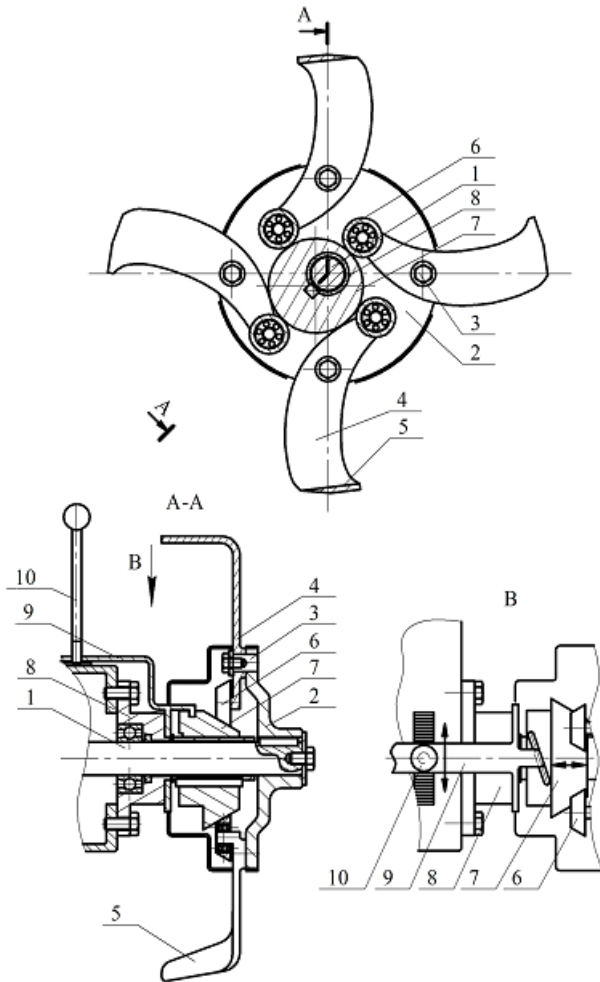

**Figure 3.** Overview of the device.

According to the description of the design, the cam profile provides the required law of motion. In these conditions, for implementation of rotary hiller cutters, first of all, we have a problem of geometric synthesis (profiling) of a cam surface. This kind of tasks is typical for the theories of mechanisms and machinery<sup>24,25</sup>. When solving them, the base is the required law of motion of an output link of a cam mechanism (movement, speed, acceleration). In our case, we have the law, which was experimentally obtained by the authors, empirical dependences of changing the angle of cutter turning  $\psi$  versus the angle of rotary hiller turning  $\phi$ , for different speeds of its movement (see Figure 4). Using the well-

known methods of synthesis of cam mechanisms in theories of mechanisms and machinery<sup>24,25</sup>, we have obtained the required profiles of the cam (Figure 5).

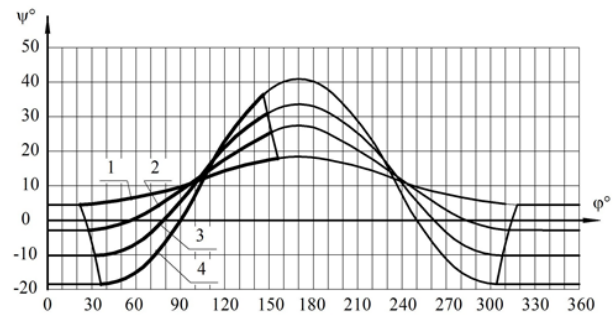

**Figure 4.** Laws of changing the angle of turning cutter  $\psi$ . Depending on the angle of turning rotary hiller  $\phi$ , properly during forward speed of rotary hiller: 1-4 km/h; 2-3 km/h; 3-2 km/h; 4-1 km/h.

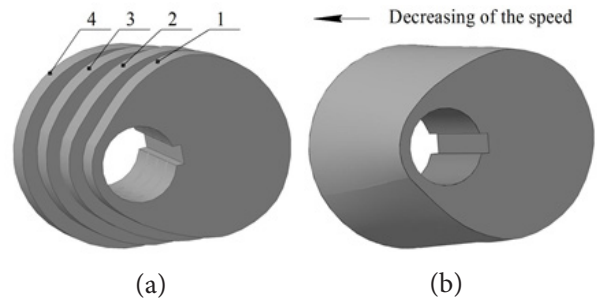

**Figure 5.** Profile of a space cam, providing the constant cutting angle at different forward speeds: a) stepped profile (1-4 km/h; 2-3 km/h; 3-2 km/h; 4-1 km/h); b) without steps.

### 3. Discussion

As noticed above, in the suggested device, the law of the cutter motion depends on the changes of forward speed of rotary hiller during the constant surface speed of the cutter. That is why for each value of speed it is necessary to determine the cam profile, which could be achieved by using the set of quick-detachable cams with required profiles, installing on the rotary hiller when the forward speed is changed. But this way is not always useful; for example, on cultivating areas with great variable firmness of soil, it is often necessary to change speed of rotary hiller and consequently it becomes necessary to stop the tillage and remove cams.

For the simplification of the design it is possible to use a cam with complicated convoluted surface (Figure 5a), each step of which corresponds to the definite

forward speed of the rotary tiller. But for all that, the regulation of cutting angle will depend on the quantity of cylindrical tracks. For the surgeless regulation it will be expedient to use a “smooth” cam with complicated convoluted surface (Figure 5b), where the knife roller will linearly move along the shaft and specify the definite law of its movement for any forward speed in the given range. The required operating condition of that kind of cam mechanism is locking of the mechanism, it means the continuous touching a running roller of the cam. In this kind of mechanism it will be impossible to provide a constant contact due to the influence of only centrifugal force on the shank and the knife, that is why it will be provided by the force locking<sup>25</sup> (using a spring installed on the shank axle).

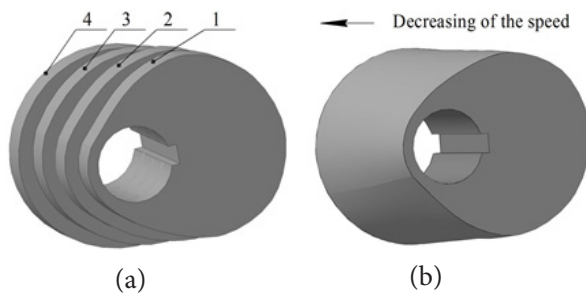

**Figure 6.** A pilot model of working member with the constant cutting angle.

Based on the research, a pilot model of working member was made and tested in the laboratory environment (Figure 6) of self-propelled compact rotary tiller, providing the constant cutting angle according to the required range of changing its forward speed. Preliminary tests have confirmed the declared requirements for modern working members (adaption to environmental changes, maintaining good quality of tillage, stability of working unit, decreasing of energy intensity and increasing of productivity, etc.).

## 4. Conclusion

Consequently, hilling soil is an energy intensive process, composed of energy consumption for: rolling and pushing of rotary tiller; cutting and throwing off soil by cutters; overcoming friction force in the transmission. Cutting of soil is more energy-intensive process, therefore it is necessary to decrease this part of energy intensity. As the research has shown, the energy intensity can

be decreased (up to 30%), if the constant cutting angle of tine rotor cutters is preserved, but existing methods and designs do not provide the solution of this problem in changing environmental conditions. As a result, the suggested method of decreasing the energy intensity due to providing the constant cutting angle along all range of working modes of rotary tillers and the device for its realization can reduce (up to 30%) energy charges for milling soil and it can provide good quality of tillage, including heavy and wet soil.

## 5. References

1. Zalign OG, Gusakov SO, Zaborski VP, et al. Low mechanization in homestead and farm hozyayst Islands. Kiev: Vintage; 1996.
2. Kanarev FM. Rotary tillage machines and tools. Moscow: Mashinostroenie; 1983.
3. Kichzhi AS. Production of tillers in China. Tractors and agricultural machinery. 1988; 2:57–9.
4. Kupryashkin VF. Resistance movement and effective use of self-propelled tillers cutters. Theory and experiment: a monograph. Saransk: Mordovia University Press; 2014.
5. Machinery and equipment for agriculture, manufactured in Russia's Regions. (cat. T. 1.). Moscow: Informagrotekh; 1997.
6. Mechanical means for producing and processing agricultural products vennoy in small farms: cat. Moscow: FSSE, Rosinformagrotekh. 2008.
7. Bernacki H. Boodonia Zużycia energii przez aktywne I kombinowane maszyny uprowowe Inst. Budown. Mekan Electr Roln Warszawa. 1975; 17:5–84.
8. Borisov VN. Investigation of dynamic characteristics and modes of tillage cutters (Author's Abstract of [PhD Thesis] in Engineering. Kyiv; 1969.
9. Vasilenko PM. On the dynamics of tillers and tractor units with rotary working members. Proceedings of the NTS VISHOM; Moscow. 1963; p. 102–18.
10. Logutenok EP. Dynamics drum rocking the tooth. Journal of Agricultural Science. 1963; 10:93–96.
11. Akimov AP. Improving the efficiency of rotational working organs and wheel propulsion mobile machines in the “movers-footprint” [Author's Abstract of PhD Thesis in Engineering]. Saransk; 2005.
12. Leshchankin AI. Research knife screw working surface milling cultivators [PhD Thesis in Engineering]. Saransk; 1971.
13. Nafikov MZ, Polyakov IS. Calculation of resistance to movement of the tractor. Tractors and farm machinery. 1968; 1:14–6.
14. Poletaev AF. Rolling driven wheels. Tractors and Farm Machinery. 1963; 2:5–7.
15. Poletaev A F. Rolling road wheel. Tractors and Farm Machinery. 1964; 1:11–5.

16. Matayshin YI, Grinchuk IM, Naumov LG, et al. Theory and design of rotary tillers. Kazan: Tatar Publishing House; 1999.
17. Senin MF. Technological and technical bases of the coincidence of soil milling with sowing. Moscow: Russian Timiryazev State Agrarian University Press; 1991.
18. Sineokov GN, Panov IM. Theory and design of tillage machines. Moscow: Mashinostroenie; 1977.
19. Popov GF. Research and technological modes of study design parameters of the working bodies of milling row cultivators [Author's Abstract of PhD Thesis in Engineering]. Moscow; 1970.
20. Zhirnov AB, Kudinov AA, Shchelkunov SA. Russian Patent 2224393. Rotary hiller with convertible cutting angle (Bulletin No. 13). 2004.
21. Zhirnov AB, Botkin AN. Russian Patent 2336680. Rotary hiller with convertible angle of the attack of working members (Bulletin No. 30). 2008.
22. Zhirnov AB, Kochnev SV. Russian Patent 2157062. Rotary hiller (Bulletin No. 28). 2000.
23. Naumkin NI, Knyazkov AS, Kupryashkin VF. (2014) Patent 2519883. Working member of rotary hiller (Bulletin # 17). 2013 (Russia).
24. Kozlovskiy MZ, Evgravov AN, Semenov YA, et al. Theory of mechanisms and membermachines. Moscow: Akademiya; 2013.
25. Frolov KV, Popov SA, Musatov AK, et al. Theory of mechanisms and machinery mechanic. Moscow: Vysshaya Shkola; 2001.