

Development of Sealed System to Transfer Mechanical Energy using Permanent Magnets

Mikhail Albertovich Mokhov* and Yuri Appolonievich Sazonov

Gubkin Russian State University of Oil and Gas (National Research University), Russian Federation;
gasseparator@mail.ru, ysaz60@mail.ru

Abstract

Background/Objectives: When developing oil and gas fields one of the most pressing problems is to reduce energy costs. Arranging more efficient use of compressed gas energy helps solve this problem. **Methods:** The compressed gas energy can be converted into thermal or electrical energy by using a special heat generator. The energy conversion usually involves several stages one of which provides for the conversion of gas flow kinetic energy into mechanical energy. At this stage of energy conversions, a gas turbine is used. Transmission is intended to transfer mechanical energy providing compliance with environmental regulations on prevention of gas emission. **Findings:** A sealed system for transferring mechanical energy can be developed by using a magnetic coupling based on permanent magnets and equipped with a sealed separating baffle. Each of two coupling halves is usually equipped with permanent magnets. As part of the undertaken works, a new design of magnetic coupling is considered in which only one coupling half is equipped with permanent magnets. The second coupling half is equipped with steel rollers serving as a magnetic circuit. In the system where compressed gas energy is converted into thermal energy, the steel rollers operate under elevated temperature, while the permanent magnets work in the area with lower temperature. The engineering task is to provide more favourable conditions for the operation of permanent magnets which will positively affect the reliability of the entire technical system. **Applications/Improvements:** The main application areas of the developed sealed system are associated with oil and gas production. However, the developed engineering solutions can be used to design other environmentally friendly equipment

Keywords: Energy Conversion, Gas, Mechanical Energy, Oil, Sealed System, Turbine

1. Introduction

One of the urgent problems refers to the high energy costs for the production and treatment of oil and gas. To solve this problem, it is advisable to organize a more rational use of the compressed gas energy at hydrocarbon reservoirs. The compressed gas energy can be converted into thermal energy. In this case, the energy conversion involves several stages one of which provides for the conversion of gas flow kinetic energy into mechanical energy. At this stage of energy conversions, a gas turbine is used which is connected with a circulation pump via transmission. Transmission serves to transfer mechanical energy ensuring compliance with environmental norms as regards gas emission prevention. A sealed system for transferring mechanical energy was developed using a new magnetic coupling based on permanent magnets,

wherein the magnetic coupling is equipped with a sealed separating baffle.

2. Literature Review

With the advent of new and more powerful magnetic materials, the known ideas¹⁻⁴ received a new impetus to develop works in the field of mechanical energy transfer with the use of permanent magnets⁵⁻⁸. The works on designing magnetic couplings for single-stage pumps⁹⁻¹⁶ and for multi-stage pumps^{17,18} are in progress. The pump pressure can be increased through the series connection of individual pump sections¹⁷. The pump flow grows under the parallel connection of individual pump sections¹⁸. To improve safety, the pump unit is fitted with a double casing¹². Special coating that protects the

* Author for correspondence

surfaces of the system components is provided to prevent damage of permanent magnets and pump parts caused by the corrosive medium¹¹. It is known that a bearing assembly with an impeller and an inner coupling half mounted thereon is a bottleneck of the sealed pump. The improvement of the bearing assembly reliability is achieved due to the enhancement of cooling conditions and by selecting engineering materials of higher quality¹⁵. The idea of using groove seals as sliding bearings with the pump impeller and the coupling half mounted thereon is being worked out¹³. To control the operation of a sealed pump, the technical possibility for axial displacement of the inner coupling half relative to the outer coupling half is used¹⁴.

In a thermal generator¹⁹⁻²², the pump ensures the circulation of the heat-transfer medium. The circulation pump is connected with the gas turbine via transmission. It is advisable to include a magnetic coupling into the transmission to create a sealed and environmentally friendly technology. As part of the studies¹⁹⁻²², the variants with various magnetic systems are considered, including the variant with a magnetic coupling.

4. Concept Headings

The subject of the ongoing study relates to the development of a sealed system to transfer mechanical energy using permanent magnets as applied to the technology of oil and gas production. Concerning the fundamental concept of the works undertaken, it is possible to name two basic principles or the rules that guided the authors of this design. The first principle is that it is advisable to arrange the permanent magnet only from one side of the sealed separating baffle. The second and the well-known principle is that it is advisable to focus the design works on the search for the simplest technical solutions.

When choosing a location for the permanent magnet, it is important to consider the following. In most cases, the material of a permanent magnet is brittle. Under the thermal overheating, the material (and the product itself) can partially or completely lose magnetic properties. In most cases, the corrosive medium has an adverse effect on the properties of a permanent magnet. It is very problematic to remove the iron-containing solid particles from the surface of a permanent magnet in a running machine. Besides, one should take into account the presence of solid particles in a fluid (gas) flow with all that it implies. In difficult field conditions, it is advisable

to arrange the permanent magnet only on one side of the sealed separating baffle in a coupling. It is expedient to arrange the permanent magnet only within the area which has more favourable operating conditions. At the same time, only a part of the magnetic circuit made of carbon steel, for example, should be placed behind the sealed separating baffle.

It makes sense to focus the design works on searching for the simplest technical solutions, but, as is well-known, it is quite difficult to find a simple solution. The field experts and designers understand that engineering “simplicity” is a matter of the “highest complexity”. As is commonly believed, a simple design is more robust, and it is usually cheaper.

5. Result

The Gubkin Russian State University of Oil and Gas conducts exploratory research studies and carries out development works in the field of creating new equipment and technologies for oil and gas production. When developing a sealed system to transfer mechanical energy, new designs of magnetic couplings were created.

Figure 1 presents a diagram of the designed magnetic coupling. Figure 2 shows a cross section A-A according to the diagram in Figure 1. Figure 3 demonstrates a diagram of a three-layer baffle.

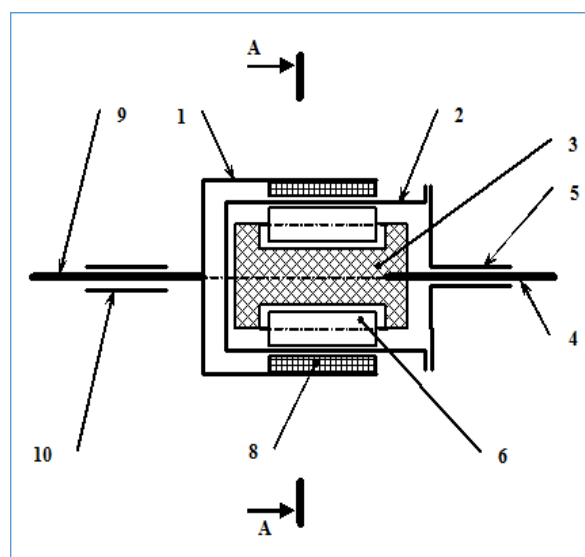

Figure 1. Scheme of the designed magnetic coupling.

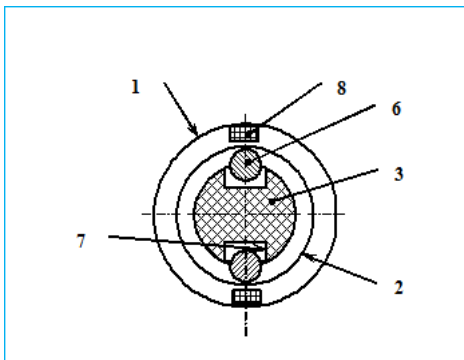

Figure 2. Cross-section A-A according to the diagram in Figure 1.

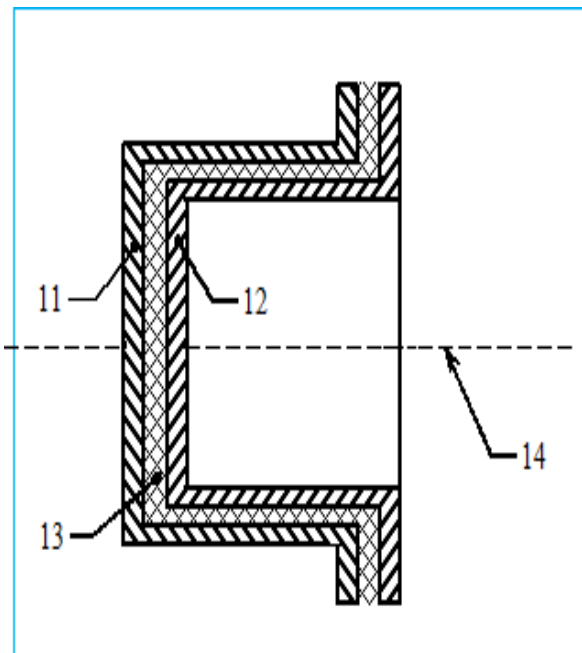

Figure 3. Scheme of a three-layer baffle (variant).

The developed magnetic coupling comprises a concentrically arranged outer coupling half 1, a fixed baffle 2, and an inner coupling half 3 assembled together with a shaft 4 and mounted in a support 5. The magnetic coupling is equipped with at least one movable roller 6 which is in contact with the inner surface of the fixed baffle 2 and with the thrust surface 7 made in the inner coupling half 3. The outer coupling half 1 is equipped with a permanent magnet 8. The outer coupling half 1 is assembled together with a shaft 9 and is mounted in a support 10.

In the present technical solution, the movable roller

6 can have a cylindrical or conical working surface. Also, the movable roller 6 can have multiple cylindrical working surfaces of different diameter, or several conical surfaces, according to the kinematics of a movable roller movement along the support surface of the respective shape.

The magnetic coupling works as follows. The outer coupling half 1 assembled together with the shaft 9 and mounted in the support 10 is driven in rotation with the delivered mechanical energy. The outer coupling half 1 is equipped with one permanent magnet 8. When rotating, the permanent magnets 8 form a rotating magnetic field. The fixed baffle 2 is made of a nonmagnetic material which makes it possible to close the magnetic flux of the magnets 8 through the movable rollers 6, wherein, due to the magnetic interaction forces (due to the attractive forces), the rollers 6 are involved into a rotational movement following the magnets 8. The rollers 6 can be made of carbon steel or other iron-containing materials. The rollers 6 move along the inner surface (in this example, along the inner cylindrical surface) of the fixed baffle 2. The magnetic coupling is equipped with at least one movable roller 6 which is in contact with the inner surface of the fixed baffle 2. The number of movable rollers 6 can be increased depending on the required torque. Each movable roller 6 is in force contact with the thrust surface 7 configured in the inner coupling half 3. In such contact interaction, the torque is transmitted to the inner coupling half 3 which is assembled together with the shaft 4 and 5 mounted in the support 5. The internal coupling half 3 and the shaft 4 are driven in rotation through the torque transmitted. The mechanical energy from the shaft 4 is transferred to other actuators that are not shown in the figures. Depending on the engineering task to be solved, the internal coupling half 3 may be made of a nonmagnetic material. If an engineering task of using the magnetic coupling as a magnetic brake (for example, in heat generators) is being solved, then the inner coupling half 3 can be made of a conductive material. In the proposed engineering solution, the gaps between the fixed baffle 2 and the inner coupling half 3 can be increased without reducing the torque transmitted by the coupling. This allows for more effective exploitation of the coupling in contaminated fluids and gases which expands the scope of the magnetic coupling application along with ensuring high reliability. Within the limits of the enlarged gaps, the movable roller 6 can shift in the radial

direction or in the direction of the angular displacement, leaving free gaps for the passage of a contaminated fluid or gas. The engineering solution results in improvement of the magnetic coupling design which will increase the efficiency and reliability of operation in contaminated fluids and gases.

In the present technical solution, the movable roller 6 can have various designs. In particular, the roller 6 may have several cylindrical working surfaces of different diameter in accordance with the kinematics of the movable roller movement along the support surface of a respective shape, subject to the operating pressure and rotational speed. This, in turn, opens up new possibilities for solving a wide range of practical problems. Thus, the problem of improving the efficiency and of enhancing the field of magnetic coupling application is solved.

It is known that under operation at high temperatures, the transmissible torque in magnetic coupling is reduced since the properties of permanent magnets can change when heated.

The engineering task solved by the present engineering solution is to stabilize the torque on the shaft under a change in the operating temperature conditions. This engineering task can be solved if the fixed baffle 2 is designed as the concentrically mounted inner and outer baffles, the gap between which encloses a heat insulator, Figure 3. This engineering solution ensures constancy of the coupling performance with regard to the transmittable torque and transmittable power given the operation under high-temperature conditions.

The fixed baffle 2 comprises an outer baffle 11 and an inner baffle 12 mounted with a gap, wherein the gap between the outer 11 and the inner 12 baffles encloses a heat insulator 13. The heat insulator 13 is made of the heat-insulating constructional material that prevents the transfer of thermal energy through the fixed baffle 2. This eliminates overheating of the permanent magnets 8, and accordingly excludes the loss of magnetic properties in the permanent magnets 8.

The outer baffle 11, the inner baffle 12, and the heat insulator 13 are concentrically arranged and are of symmetrical shapes with respect to the axis 14. The support 10 and the additional support 5 provide for the conditions of the shaft 9 and the additional shaft 4 rotation around the axis 14. A concentric arrangement of baffles 11, 12, 13 ensures the conditions for transfer of mechanical energy providing the outer coupling half 1

and the inner coupling half 3 with rotational movement. The inner coupling half 3 can be filled with liquid heat-transfer medium (as part of a heat generator) and is capable of operating at high temperatures because it contains no permanent magnets exposed to the negative influence of (temperature) heating. The heat insulator 13 stops the heat flux through the fixed baffle 2 eliminating the heat rise in the permanent magnets 8 on the outer coupling half 1 and excluding the thermal energy loss. The constancy of magnets temperature ensures the constancy of the coupling performance with regard to the transmissible torque. Excluding the loss of thermal energy provides for the constancy of the engineering system performance with regard to the transferable power (for example, in a heat generator, where mechanical energy is transferred through the magnetic coupling to the pump impeller filled with liquid heat-transfer medium). Thus, the engineering task concerning the torque stabilization on the shaft under the changed temperature conditions is solved. It is planned to use the presented engineering solutions for creating sealed systems in which the magnetic coupling is integrated into the transmission mechanism to transfer mechanical energy by ensuring compliance with environmental regulations on prevention of gas emission.

Figures 1–3 demonstrate the variant of the magnetic coupling in which the permanent magnets are arranged on the outer coupling half (variant A). However, it is possible to design another magnetic coupling structure (variant B) in which the permanent magnets are arranged on the inner coupling half. In this case, the steel rollers are arranged on the outer coupling half.

Figures 4–7 show the developed model of the magnetic coupling according to variant B. The permanent magnets are arranged on the inner coupling half, Figure 4. The magnetic coupling model was tested under the shaft speeds up to 3,000 rpm. A possibility of transferring mechanical energy to the circulation pump forming part of the heat generator was checked.

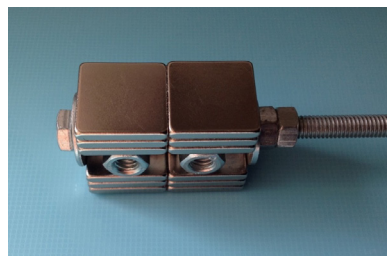

Figure 4. Inner coupling half configured according to variant B.

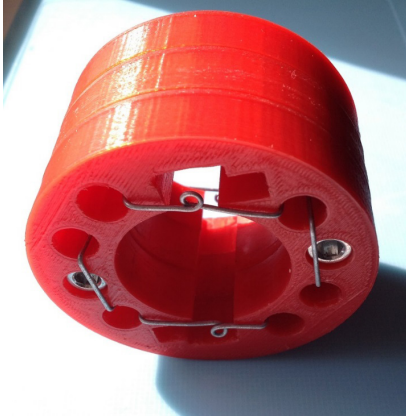

Figure 5. Outer coupling half configured according to variant B.

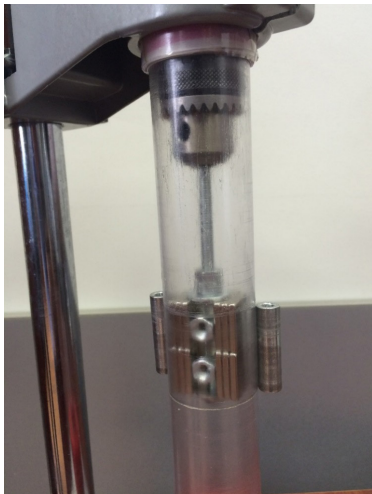

Figure 6. Inner coupling half configured according to variant B is arranged inside a fixed transparent baffle (two steel rollers can be seen on the outer surface of the transparent baffle)..

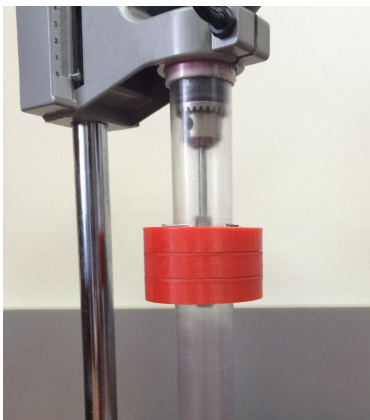

Figure 7. The magnetic coupling model configured according to variant B.

To conduct a quantitative assessment, it is proposed to use the “specific force” (F_v) parameter when comparing different magnetic couplings. The total volume of all magnets comprised by the magnetic coupling can be designated as V . If the maximum torque transmitted through the coupling is designated as F and the radius of the inner coupling half as R , then the force transmitted through the fixed baffle can be approximately calculated by a simplified formula:

$$F=M/R \quad (1)$$

To calculate the “specific force” value, the following formula can be used:

$$F_v=F/V \quad (2)$$

A preliminary analysis of the literature data allowed the authors to draw some interim conclusions. When using permanent magnets of the Nd-Fe-B type (neodymium-iron-boron), the commercially available magnetic couplings demonstrate the F_v value of “specific force” at the level of 8 newtons per cubic centimetre (N/cm^3). The laboratory tests of the developed magnetic couplings presented in Figures 1–7 show that this configuration of the magnetic coupling can also provide for obtaining the F_v value of “specific force” equal to $8 N/cm^3$.

5. Discussion

Analysis of the technical publications allows one to note that a simple and reliable design of the magnetic coupling is still under development. To achieve the engineering result, the variants, where one assembly performs the functions of two or more assemblies, are under consideration. This is the way in which the possibility of using groove seals as sliding bearings is being studied¹³. It is known that the works on designing a magnetic coupling for multi-stage pumps are in progress.¹⁷ The direction of this work is prospective for the development of magnetic coupling designs with roller magnetic circuits²².

As part of the ongoing research study, a new design of magnetic coupling is considered in which only one coupling half is equipped with permanent magnets. Meanwhile, the second coupling half is equipped with steel rollers serving as a magnetic circuit. The magnetic coupling is designed for the energy-saving system, where the compressed gas energy is converted into thermal energy. The steel rollers operate under elevated temperature, while the permanent magnets work in an

area with lower temperature. Thus, the engineering task of providing more favourable conditions for the operation of permanent magnets is being solved which in turn enhances the reliability of the entire engineering system with the heat generator.

It is proposed to use the F_v “specific force” criterion to compare technical characteristics of various magnetic couplings regardless of the coupling size and irrespective of the weight of magnets comprised by the coupling. The results of testing the new coupling models allow us to draw interim conclusions that a new coupling design is not inferior to the commercially available samples in terms of the “specific force” criterion. At the same time, the contact of magnets with the corrosive medium and with the high-temperature environment can be completely avoided in the new coupling.

In the course of the research, a relatively new trend in the field of magnetic coupling production is distinguished. When the rollers are used as the magnetic circuit, the design of magnetic coupling is considerably simplified in a number of cases. The simplification of coupling design can contribute to reducing the cost of the equipment developed and to improving its reliability.

For the development of the research work presented, it is planned to develop a complete theoretical framework which would involve computer simulations to optimize the experimental work on the bench test sets.

In the heat generator^{19–22}, a part of the energy can be converted into electrical energy by using electromechanical transmission and mounting the magnetic coupling between the gas turbine and electric generator. In this case, the application area of the heat generator with magnetic coupling expands significantly due to the universality of the electromechanical transmission.

The developed engineering solutions can also be used when designing other types of environmentally friendly equipment in the field of pipeline valves, pump and compressor equipment as well as in the field of automation and robotics.

6. Conclusion

The study presents some of the results of the research and development works aimed at a partial solution of the urgent and complex problem related to the high energy costs for the production of hydrocarbons. The goal can

be achieved through more efficient use of the compressed gas energy. In our view, in the course of the research conducted, a relatively new trend in the field of magnetic coupling production is distinguished. When the rollers are used as the magnetic circuit, the design of magnetic coupling and the sealed system itself which is intended to transfer mechanical energy using permanent magnets, can be considerably simplified in a number of cases. At the same time, the design simplification, as is known, can result in reducing the cost of the equipment under development and in improving the reliability of this equipment. For the development of the research work presented, it is planned to develop a complete theoretical framework which would involve computer simulations.

7. Acknowledgement

The work was conducted as part of the applied research studies and was financially supported by the Ministry of Education and Science of the Russian Federation (the unique identifier No. RFMEFI57414X0129).

8. References

1. Faus HT. United States Patent 2243555. Magnet gearing [Internet]. Publication Date: 1941 May 27. Available from: <http://www.freepatentsonline.com/2243555.html>.
2. Meyer CJ. United States Patent 2722617. Magnetic circuits and devices [Internet]. Publication Date: 1955 Jan 11. [cited 2016 Jul 06]. Available from: <http://www.freepatentsonline.com/2722617.html>.
3. Zozulin IV. United States Patent 2827856. Axial flow magnetic drive pumps [Internet]. Publication Date: 1958 Mar 25. [cited 2016 Jul 06]. Available from: <http://www.freepatentsonline.com/2827856.html>.
4. Baermann M. United States Patent 3273001. Permanent magnet device for generating electrical energy [Internet]. Publication Date: 1966 Sep 13. [cited 2016 Jul 06]. Available from: <http://www.freepatentsonline.com/3273001.html>.
5. Li X, Chau K-T, Cheng M, Hua W. Comparison of magnetic-gear permanent-magnet machines. *Progress in Electromagnetics Research*. 2013; 133:177–98.
6. Uno M, Masuzoe T, Aotani I. Development of the floating centrifugal pump by use of non-contact magnetic drive and its performance. *International Journal of Rotating Machinery*. 2004 Jan; 10(5). DOI: 10.1155/S1023621X0400034X.
7. Pranab S, Harish H. Magnetic bearing configurations: theoretical and experimental studies. *IEEE Transactions on Magnetics*. 2008 Feb; 44(2):292–300.
8. Ravaut R, Lemarquand G. Magnetic couplings with cylin-

- dricial and plane air gaps: Influence of the magnet polarization direction. *Progress in Electromagnetics Research B*.2009; 16:333–49.
9. Motoshige M. United States Patent 4722661. Magnetic-drive centrifugal pump[Internet].Publication Date: 1988 Feb 02. [cited 2016 Jul 06]. Available from: <http://www.freepatentsonline.com/4722661.html>.
 10. Bolleter U. United States Patent 4780066. Centrifugal pump having a magnetic coupling[Internet].Publication Date: 1988 Oct 25.[cited 2016 Aug 08]. Available from: <http://www.freepatentsonline.com/4780066.html>.
 11. Masayuki K. United States Patent 4850818. Corrosion-resistant magnet pump[Internet].Publication Date: 1989 Jul 25. [cited 2016 Jul 06]. Available from: <http://www.freepatentsonline.com/4850818.html>.
 12. Kazuo O. United States Patent 5066200. Double containment pumping system for pumping hazardous materials[Internet]. Publication Date: 1991 Nov 19. [cited 2016 Jul 06]. Available from: <http://www.freepatentsonline.com/5066200.html>.
 13. Hinckley CJ. United States Patent 5201642. Magnetic drive pump[Internet]. Publication Date: 1993 Apr 13. [cited 2016 Jul 13]. Available from: <http://www.freepatentsonline.com/5201642.html>.
 14. Kazunari A. United States Patent 7922464. Magnetic drive pump[Internet]. Publication Date: 2011 Apr 12. [cited 2016 Dec08]. Available from: <http://www.freepatentsonline.com/7922464.html>.
 15. Chi-Wei S. United States Patent Application 20040131485. Sealed magnetic drive sealless pump[Internet]. Publication Date: 2004 Jul 08. [cited 2016 Aug 07]. Available from: <http://www.freepatentsonline.com/y2004/0131485.html>.
 16. Seiya T. United States Patent Application 20050095149. Magnetic drive pump[Internet].Publication Date: 2005 May 05. [cited 2016 May 05]. Available from: <http://www.freepatentsonline.com/y2005/0095149.html>.
 17. Toshio K. United States Patent 4678409. Multiple magnetic pump system[Internet].Publication Date: 1987 Jul 07. [cited 2016 Jul 07]. Available from: <http://www.freepatentsonline.com/4678409.html>.
 18. Naotake S. United States Patent 4850821. Multiple magnet drive pump[Internet]. Publication Date: 1989 Jul 25.[cited 2016 Jul 25]. Available from: <http://www.freepatentsonline.com/4850821.html>.
 19. Sazonov IA,Mokhov MA. Design of thermoelectric generators for oil and gas production systems. *Indian Journal of Science and Technology*.2015 Nov; 8(30):1–12.
 20. Sazonov IA, Mokhov MA, Frankov MA,Biktimirova DR. Studying issues of compressed gas energy recovery. *Indian Journal of Science and Technology*. 2016 May;9(19). DOI: 10.17485/ijst/2016/v9i19/93904, 1-7.
 21. Bondarenko VV, Mokhov MA, Sazonov YuA. On the development of thermal generators for oil and gas production. *Oil Industry*. 2015;12:127–9.
 22. Sazonov YuA, Mokhov MA, Gruzintsev DA, Basharov SF. Patent No. 160267. Magnetic coupling. Application for utility model No. 2015142453/07. Published: 2016 Oct 03. Bulletin No. 7.