

A Novel Method of Equivalencing DFIG based Wind Farm for Stability Studies

D. Maharajan^{1*}, R. P. Kumudinidevi², V. Preethakumari² and C. Selvendiran¹

¹Department of Electrical and Electronics Engineering, SRM University, Chennai – 603203, Tamil Nadu, India; maharajan.ps@gmail.com, eesselvan@gmail.com

²Power Systems Division, College of Engineering, Guindy, Anna University, Chennai – 600025, Tamil Nadu, India; rpkdevi@gmail.com, vpreeth23@gmail.com

Abstract

Objectives: Analyzing the stability of large scale wind power plant (WPP) is very cumbersome and simulation time required performing the analysis is long-drawn-out. Thus a single equivalent model of WPP is developed. **Methods/Statistical analysis:** Kron's based network reduction is proposed for the WPP. Two network reduction methodologies are adopted and wind turbine mechanical and electrical parameters are rescaled which is discussed in detail in the paper. Transient stability analysis is performed to validate the equivalence method. Study system consists of 23 buses with 20 DFIG wind turbine generating units connected to the main grid of utility system. **Findings:** Transient stability analysis is conducted for the study system. Dynamic response of detailed WPP and proposed equivalent system matches accurately for the three phases to ground fault disturbance at point of common coupling (PCC). At PCC the Voltage, Real power and Reactive power values are very close to proposed equivalent system when compared to detailed WPP. In addition, the percentage error computed is least for the proposed system. Time taken to simulate the equivalent system is very less compared to the detailed WPP and existing literature work. All the simulations are carried out in DiGSILENT Power Factory™ software. **Application/Improvements:** Remarkable simulation time reduction and accuracy is achieved for the proposed method. Thus, the equivalent method is applied for quick assessment of transient stability of large scale WPP.

Keywords: Dynamics Response, Kron's Reduction, Large Scale Wind Power Plant, Network Reduction, Transient Stability

1. Introduction

The need for energy demand is growing in a faster way. In developing countries like India, renewable energy plays a key role because of two reasons. Firstly, the country driven to reduce greenhouse gases opting for renewable energy. Secondly the load demand is always greater than generation. Wind energy plays a major role in renewable energy. Thus to analyze the effect of wind energy on to the power system in a simpler way; the entire wind plant with huge number of Wind Turbine Generating (WTG) units represented as a single equivalent. A simple aggregation is investigated in paper¹. Where two equivalent wind turbines are developed. One for aggregated wind turbine with same wind speed and other is for different incoming wind speed. Reduced order dynamic equivalent proposed

for SCIG based wind farm in paper², which provide good accuracy with detailed model. DFIG is preferred over fixed speed wind turbine generators as it offers numerous advantages³. Then today comes the era of DFIG wind turbine generating units. They are energy efficient and their operating conditions optimized. Thus, dynamic equivalent formed for wind farm consisting of DFIG wind turbines. Since DFIG consists of number of controllers like pitch controller, real power controller and reactive power controller which posed a great challenge in forming dynamic equivalent. These are challenges addressed and simple aggregation techniques were illustrated in paper⁴, the order of the aggregated model is reduced by using selective modal analysis. It focuses on the most relevant modes and variables. Further dynamic equivalent is formed using parameter identification⁵. The model is

*Author for correspondence

written in the form of deterministic auto regressive moving average. DFIG wind turbines are clustered based on coherency multi equivalent formed and parameters are estimated to ensure stable convergence⁶. A review on different dynamic equivalent methods for large scale system is given in paper⁷. Recently, in paper⁸ a steady state equivalent circuit of Doubly Fed Induction Machine (DFIM) is obtained by considering the relative position of rotor with respect to synchronously rotating reference frame and direction of rotor magnetic flux due to rotor current. Change in spatial orientation of RMF is observed when the DFIM is operating at sub-synchronous and super-synchronous mode of operation.

This paper organized in to six sections. Description about each section is as follows.

Section 2 concisely explains the modeling of Wind Turbine Generator System components. Section 3 dealt with wind power plant description under consideration. Section 4 explains dynamic equivalent formation of the wind power plant in detail. The simulation results of detailed plant model and the dynamic equivalent model shown and compared in section 5. Inference and conclusion of this paper explained in section 6.

2. Modelling of Wind Turbine Generation System Components

2.1 Wind Turbine Model

The simple aerodynamic model is used to represent the turbine. The power extracted from the wind can be calculated by the given formula⁹.

$$P_m = \frac{1}{2} \rho A V_{wind}^3 C_p(\lambda, \theta) \tag{1}$$

The power coefficient C_p is a function of λ (tip speed ratio) and θ (pitch angle).

The general functional representation of C_p is

$$C_p(\lambda, \theta) = C_1 \left(\frac{C_2}{\lambda} - C_3 \theta - C_4 \theta^x - C_5 \right) e^{-\frac{C_6}{\lambda}} \tag{2}$$

$$\frac{1}{\lambda} = \frac{1}{\lambda + 0.08\theta} - \frac{0.035}{1 - \theta^3} \tag{3}$$

C_1 to C_6 and x are constants whose values are given in book¹⁰

The tip speed ratio is given by

$$\lambda = \frac{\omega_r R}{V_{wind}} \tag{4}$$

The tip speed ratio (λ) is maintained at optimum value to extract optimum power from the wind turbine. This is possible only in DFIG wind turbines as wind speed varies, rotor speed can be varied to maintain (λ_{opt}).

2.2 Modelling of Doubly Fed Induction Generator

A DFIG is a slip ring induction machine where the stator and rotor-circuits are energized. The rotor is fed from an electric source namely rotor side converter¹⁰. This nature of DFIG enables it to operate at variable speed. Mechanical side and electrical side of the machine is decoupled producing constant frequency when connected to grid.

Three phase stator and rotor is referred to synchronously rotating reference frame with quadrature axis (q axis) leading direct axis (d axis) by 90 degrees. The controller models shown Figure 1 to Figure 3 used in the DFIG model of WTG. Generator convention is used i.e. stator current and rotor current are considered to be positive when they are leaving and entering the machine respectively.

All the expressions are in per unit. The stator and rotor voltage equations are

$$\frac{1}{\omega_s} \frac{d\psi_{qs}}{dt} = V_{qs} + R_s I_{qs} - \psi_{ds} \tag{5}$$

$$\frac{1}{\omega_s} \frac{d\psi_{ds}}{dt} = V_{ds} + R_s I_{ds} + \psi_{qs} \tag{6}$$

$$\frac{1}{\omega_s} \frac{d\psi_{qr}}{dt} = V_{qr} - R_r I_{qr} - \frac{(\omega_s - \omega_r)}{\omega_s} \psi_{dr} \tag{7}$$

$$\frac{1}{\omega_s} \frac{d\psi_{dr}}{dt} = V_{dr} - R_r I_{dr} + \frac{(\omega_s - \omega_r)}{\omega_s} \psi_{qr} \tag{8}$$

The stator and rotor flux linkage equations are

$$\psi_{qs} = -X_s I_{qs} + X_m I_{qs} \tag{9}$$

$$\psi_{ds} = -X_s I_{ds} + X_m I_{dr} \tag{10}$$

$$\psi_{qr} = -X_m I_{qs} + X_r I_{qr} \tag{11}$$

$$\psi_{dr} = -X_m I_{ds} + X_r I_{dr} \tag{12}$$

The Tenth order model of DFIG is given by

$$\frac{dE'_{dq}}{dt} = \frac{-1}{T'_d} (E'_{dq} + (X_s - X'_d)I_d + (\omega_s \frac{X_m}{X_s} V_{dr} - (\omega_s - \omega) E'_{dq})) \quad (13)$$

$$\frac{dE'_{dq}}{dt} = \frac{-1}{T'_q} (E'_{dq} - (X_s - X'_q)I_q - (\omega_s \frac{X_m}{X_s} V_{qr} - (\omega_s - \omega) E'_{dq})) \quad (14)$$

$$\frac{d\omega_r}{dt} = \frac{\omega_s}{2H_D} [T_m - E'_{dD} I_{qs} - E'_{qD} I_{qs}] \quad (15)$$

$$\frac{dx_1}{dt} = K_{I1} (P_{ref} - P_{gen}) \quad (16)$$

$$\frac{dx_2}{dt} = K_{I2} (K_{P1} P_{ref} - P_{gen}) + x_1 - I_{qr} \quad (17)$$

$$\frac{dx_3}{dt} = K_{I3} (Q_{ref} - Q_{gen}) \quad (18)$$

$$\frac{dx_4}{dt} = K_{I4} (K_{P3} (Q_{ref} - Q_{gen}) + x_3 - I_{dr}) \quad (19)$$

$$\frac{dx_5}{dt} = K_I (\omega_r - \omega_{ref}) \quad (20)$$

$$\frac{dx_6}{dt} = x_5 - x_6 - \theta + K_p (\omega_r - \omega_{ref}) \quad (21)$$

$$\frac{d\theta}{dt} = x_6 \quad (22)$$

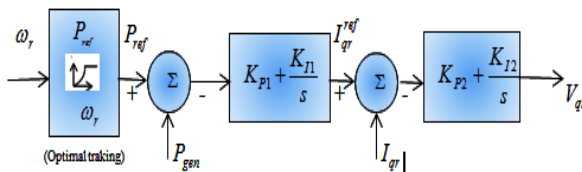

Figure 1. Rotor speed controller.

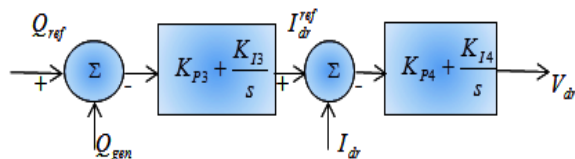

Figure 2. Reactive power controller.

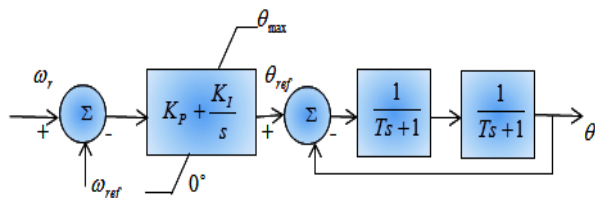

Figure 3. Pitch angle controller

2.3 Modelling of Wind Speed

Wind model consists of four components

$$V_{wind}(t) = V_a + V_r(t) + V_g(t) + V_t(t) \quad (23)$$

Gust and ramp component are combined and defined as a variable wind component (it is also called gust). Therefore, an average value and a variable component are used to represent the wind speed profile at every WTG¹⁰.

3. Detailed Wind Power Plant

The wind power plant considered in this paper consists of 20 DFIG units connected to utility system at the point of common coupling. The total installed capacity of the wind power plant is 20 MW. Identical DFIG units are considered. The WPP network of 24 bus system is given in Appendix Figure 4. DFIG wind generators are arranged in 5 rows. Non-uniform distribution of wind speed is considered. The generators located in first row receive higher wind speed and the wind speed decreases slightly as we move across the rows.

Electrical and mechanical parameters of the wind power plant are given in paper¹¹. The single line diagram of the entire wind power plant as shown in Appendix Figure.4 and the single equivalent is given in Figure 5.

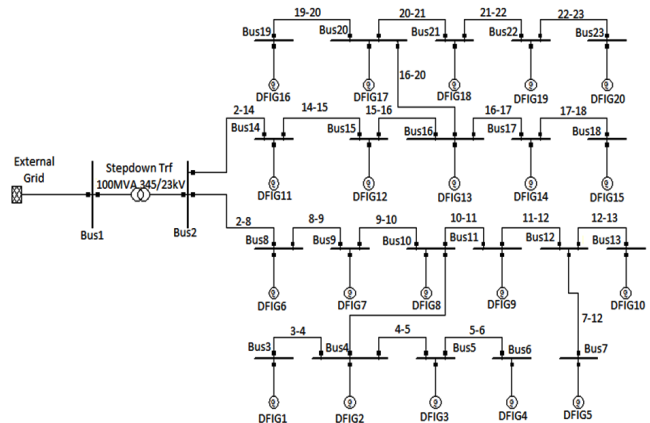

Figure 4. The Single line diagram of the detail wind power plant.

4. Procedure for Dvnamic

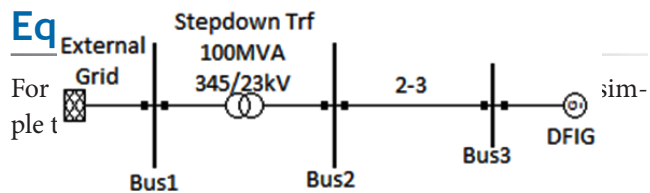

Figure 5. Reduced equivalent system.

- Equivalent mechanical parameters are obtained for equivalent WTGS.
- Equivalent electrical and controller parameters are obtained for equivalent WTGS.
- Two network reduction methodologies are used.

4.1 Equivalent Mechanical Parameters

The total mechanical power is given by

$$Pm^e = \sum_{i=1}^{ng} P_m^i = \sum_{i=1}^{ng} \frac{1}{2} \rho A_{wt}^i C_p^i (\lambda^i, \theta^i) v_{wind,i}^3 \tag{24}$$

Where ng is the number of WTGS in the wind power plant. The blade length of equivalent wind turbine is same as that of the individual wind turbine.

Then the equivalent wind power becomes

$$Pm^e = \frac{1}{2} \rho A_{wt} C_p^e (\lambda^e, \theta^e) \sum_{i=1}^{ng} v_{wind,i}^3 \tag{25}$$

The equivalent wind speed is given by

$$V_{wind}^e = \sqrt[3]{\frac{\sum_{i=1}^{ng} v_{wind,i}^3}{ng}} \tag{26}$$

Thus the equivalent angular speed, ω_p , is defined in the same speed range as the angular speed of the individual turbines.

$$T_m^e = ng \left[\frac{1}{2} \rho \frac{\pi R^2}{S_b} w_s c_p^e (\lambda^e, \theta^e) \frac{v_{wind}^{e3}}{w_r^e} \right] \tag{27}$$

$$T_m^e = B^e \left[w_s c_p^e (\lambda^e, \theta^e) \frac{v_{wind}^{e3}}{w_r^e} \right] \tag{28}$$

Where B^e is the torque parameter for calculating either mechanical torque or power of a WTG.

The equivalent generator inertia constant H^e is given by

$$H^e = \sum_{i=1}^{ng} H_i \tag{29}$$

The equivalent generator parameters in p.u (100 MVA Base) are given in Table 1.

Table 1. WTGS parameters of simple equivalent system

Parameters	Values in p.u.
Stator reactance(X_s)	0.1777

Rotor reactance(X_r)	0.1792
Magnetizing reactance(X_m)	0.1754
Stator resistance(R_s)	0.0050
Rotor resistance(R_r)	0.0044

4.2 Equivalent electrical and controller Parameters

Voltage magnitude of equivalent is same as that of the individual wind turbine. Current magnitude is ng times larger.

$$T_g^e = \sum_{i=1}^{ng} T_{gi} = E'_{dD} \sum_{i=1}^{ng} I_{dsi} + E'_{qD} \sum_{i=1}^{ng} I_{qsi} \tag{30}$$

$$T_g^e = E'_{dD} I_{ds}^e + E'_{qD} I_{qs}^e \tag{31}$$

where

$$I_{ds}^e = \sum_{i=1}^{ng} I_{dsi} \quad I_{qs}^e = \sum_{i=1}^{ng} I_{qsi} \tag{32}$$

The total power injected to rotor in the equivalent model is

$$T_r^e = V_{qr} \sum_{i=1}^{ng} I_{qri} + V_{dr} \sum_{i=1}^{ng} I_{dri} \tag{33}$$

$$T_r^e = V_{qr} I_{qr}^e + V_{dr} I_{dr}^e \tag{34}$$

All other electrical parameters are scaled as follows.

$$X_m^e = \frac{X_m}{ng} \quad X_1^e = \frac{X_1}{ng} \quad X_2^e = \frac{X_2}{ng} \quad X_s^e = \frac{X_s}{ng} \tag{35}$$

$$R_2^e = \frac{R_2}{ng} \text{ and } R_1^e = \frac{R_1}{ng}$$

The active and reactive power reference for the equivalent controller

$$P_{ref}^e = \sum_{k=1}^{ng} P_{ref,k} = C \sum_{k=1}^{ng} \omega_r^{e3} = C^e \omega_r^{e3} \tag{36}$$

$$Q_{ref}^e = \sum_{k=1}^{ng} Q_{ref,k} = ng * Q_{ref} \tag{37}$$

$$K_{p2}^e = \frac{K_{p2}}{ng} \quad K_{p4}^e = \frac{K_{p4}}{ng} \quad K_{I2}^e = \frac{K_{I2}}{ng} \quad K_{I4}^e = \frac{K_{I4}}{ng} \tag{38}$$

The following parameters are magnified by number of generators (ng) times

$$P_{ref}^e, P_{gen}^e, X_1^e, I_{qr}^e, Q_{ref}^e, Q_{gen}^e, X_3^e, I_{dr}^e \tag{39}$$

All other parameters remain equal to those used for the individual turbines.

4.3 Network Reduction Methodology

The Network consisting of 23 buses is reduced to 3 buses by network reduction. The equivalent impedance ($R + jX$) is connected to bus 2 and the single equivalent generator is connected to bus 3. Two Network reduction methodology is proposed in this paper.

4.4 Method 1-Simple method

The concept developed in the paper is based on the conservation of real power consumed and reactive power consumed/generated by the collector systems. Since Identical DFIG's are used, the current which is injected is the same.

$$Z_s = \frac{\sum_{m=1}^n m^2 Z_m}{n^2} \tag{40}$$

Where Z_m represents the individual series impedances. Similarly, the same equation can be used for the entire power plant. It is computed by using the total losses in the collector system. This method is clearly explained in paper ¹².

$$r_{EQ} = \frac{\sum_{k=1}^1 \sum_{m=1}^{n_k} m^2 Z_n}{n_{wtg}^2} \tag{41}$$

4.5 Method 2-Kron's Reduction

Kron's Reduction is used for Network reduction of entire power plant. The procedure for the network reduction is given as follows

- Admittance Matrix [Y] for the given wind power plant is obtained. It includes bus1 to bus 23. The dimension of the Y matrix is 23*23.
- Kron's reduction is applied to retain bus 3 to get equivalent impedance.
- The reduction formula is given by

$$R_s + jX_s = \frac{1}{[Y_{RR}] - [Y_{RE}][Y_{EE}]^{-1}[Y_{ER}]} \tag{42}$$

Where Y_{RR} dimension is 1*1 which corresponds to retained bus after Kron's reduction. Y_{ER} Dimension is 1*E sub matrix of [Y] where E is the number of buses eliminated after Kron's reduction. Y_{RE} is transpose of Y_{ER} . Y_{ER} Dimension is E*E.

5. Dynamic Simulation

Comparison Results

The detailed, existing and proposed equivalent systems are simulated using DIgSILENT PowerFactory software¹³. The state variables are initialized by power flow analysis. Balanced, positive sequence, AC power flow method is used for initialization. The voltage dependency of loads is considered. The network is represented as balanced and positive sequence. The step size for the electromechanical transients is 0.001 sec.

A three phase fault is applied at bus 2 at 1 sec for both the detailed system and equivalent system. The fault is cleared at 1.1 sec. The dynamic response of wind Power plant under a grid disturbance is plotted. The variation of voltage, real power and reactive power and current, when fault occurs at bus 2 are also discussed.

It is observed from the Figures 6 to Figure 10, the dynamic response of detailed system and equivalent systems match accurately. But the Figure 10 the proposed equivalent is not following the speed of detailed system because proposed equivalent single DFIG machine. To get a better dynamic response of proposed system, the combined machine and turbine inertia has to be optimized. Whenever a 3 phase fault occurs at bus 2, the voltage fall reach the wind turbines, Figure 6 real power generated reduces but mechanical power remains the same hence the machine accelerates. When the voltage recovers, as the speed of rotation is higher, active power tends to be slightly higher. The proposed equivalent system proved more accurate than the existing system.

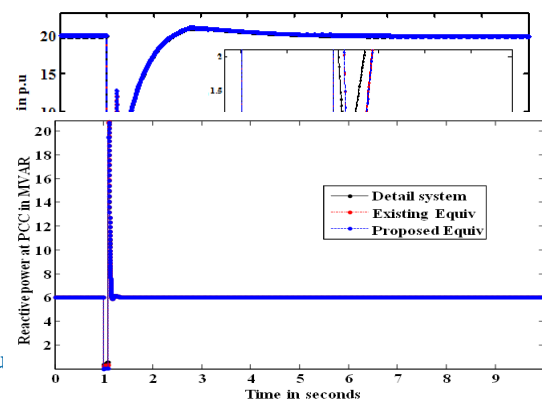

Figure

Figure 7. Reactive power at PCC.

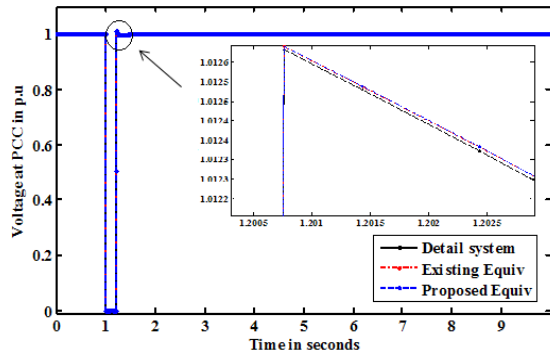

Figure 8. Voltage at PCC.

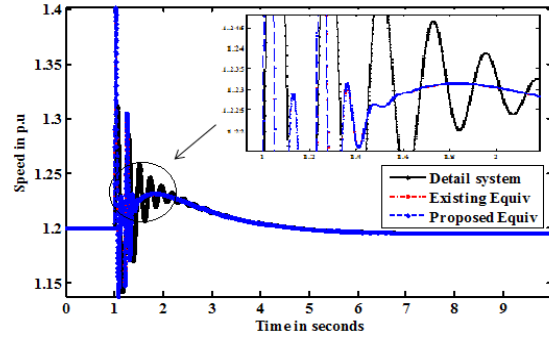

Figure 10. DFIG rotor speed.

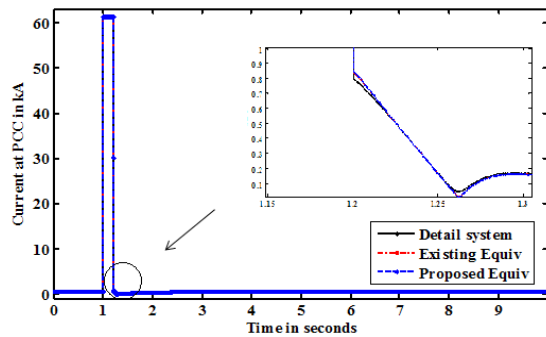

Figure 9. Current at PCC.

The study is extended to line to line and single phase to ground faults. The real power (P), reactive power (Q) and voltage (V) of proposed, existing system are compared with detailed system as shown in Appendix Table 2. This clearly shows that proposed system is much closer to detail system.

It is inferred from Table 3 (given in Appendix) that time required to simulate equivalent system is very less compared to the detailed system. Processor – Intel® core™ i3 -4005U CPU @ 1.70 GHz is used for this simulation.

Table 3. Simulation time comparison

Simulation Test cases	Detail system	Existing Equivalent	Proposed Equivalent
Three phase to ground fault	216 sec	8.34 sec	8.34 sec
Line to Line fault	213 sec	9.52 sec	9.51 sec
Single phase to ground fault	242 sec	10.06 sec	10.04 sec

Table 2 .Comparison between Detail system, Existing system and Proposed system

Fault Cases at bus 2 %error(detail vs existing)		% Error of variables in different		P,Q,V values at PCC		
		% error (detail vs existing)	Detail System	Existing system	Proposed System	% error (detail vs proposed)
Three phase fault	P(MW)	0.1309	19.088	19.113	19.074	0.0733
	Q(Mvar)	2.78	-1.042	-1.013	-1.042	0
	V (p.u)	0.000809	0.988533	0.988541	0.988532	0.000101
Line-Line fault	P(MW)	0.0811	19.014	19.05	18.995	0.0717
	Q(Mvar)	0.6745	4.8282	4.8607	4.8287	0.0143
	V(p.u)	0.000908	0.98036	0.98037	0.98036	0.0001
Single-phase fault	P(MW)	0.189	19.2217	19.2373	19.2079	0.099
	Q(Mvar)	0.673	4.8773	4.9102	4.878	0.0103
	V(p.u)	0.000918	0.990307	0.990316	0.990306	0.00622

6. Conclusion

A method of forming dynamic equivalent of entire WPP is proposed in this paper. The transient stability performance of detailed power plant and the equivalent system is almost the same which validates our equivalence approach. Simulation time required to perform transient stability analysis is very less for proposed equivalent system than the detailed WPP system.

7. References

1. Fernández LM, Jurado F, Saenz JR. Aggregated dynamic model for wind farms with doubly fed induction generator wind turbines. *Renewable Energy*. 2008 Jan; 33(1):129–140.
2. Galan HN, Canedo CJ, Loukianov A. Equivalent models of wind generation systems with SCIG. In *2012 Power Engineering and Automation Conference*. 2012 Sep. p. 1–6.
3. Shaik JB, Burthi LR. Application of power matrix technique for controlling DFIG wind turbine system. *Indian Journal of Science and Technology*. 2015 Sep; 8(23):1–5.
4. Pulgar-Painemal HA, Sauer PW. Power system modal analysis considering doubly-fed induction generators. In *Bulk Power System Dynamics and Control (iREP)-VIII (iREP)*, 2010 iREP Symposium 2010 Aug. p. 1–7.
5. Kim DE, El-Sharkawi MA. Dynamic equivalent model of wind power plant using parameter identification. *IEEE Transactions on Energy Conversion*. 2016 Mar; 31(1):37–45.
6. Ali M, Ilie IS, Milanović JV, Chicco G. Probabilistic clustering of wind generators. In *IEEE PES General Meeting*. 2010 Jul. p. 1–6.
7. Zhou HQ, Song ZP, Wang JP, Xue Y. A review on dynamic equivalent methods for large scale wind farms. In *Power and Energy Engineering Conference (APPEEC)*. 2011 Asia-Pacific. 2011 Mar. p. 1–7.
8. Kumar SS, Thukaram D. Alternate proof for steady-state equivalent circuit of a doubly fed induction machine. *IEEE Transactions on Power Electronics*. 2016 Aug; 31(8):5378–83.
9. Lubosny Z, Lubosny Z. *Wind turbine operation in electric power systems. Advanced modeling*. Heidelberg: Springer. 2003 Sep. p. 60–90.
10. Heier S. *Grid integration of wind energy: onshore and offshore conversion systems*. Wiley-Blackwell, 3rd Edition. 2014 Jun.
11. Pulgar Painemal HA. *Wind farm model for power system stability analysis*. Doctoral Dissertation. University of Illinois at Urbana-Champaign. 2011 Jan.
12. Muljadi E, Pasupulati S, Ellis A, Kostrov D. Method of equivalencing for a large wind power plant with multiple turbine representation. In *Power and Energy Society General Meeting-Conversion and Delivery of Electrical Energy in the 21st Century*. 2008 Jul. p. 1–9.
13. DlgSILENT Power Factory V14 – User Manual. file:///C:/Users/laptop/Downloads/Whats_New_V14_1.pdf. Date Accessed: 2/02/2010.