

Novel Design and Performance Analysis of Rectangular Frequency Reconfigurable Micro Strip Patch Antenna using Line Feed technique for Wireless Applications

G. Jegan¹, A.Vimala Juliet², M. Florence Silvia³ and G. B. V. Sai Krishna¹

¹Department of ECE, Sathyabama University, Chennai 600119, TamilNadu, India; jjsfss@gmail.com, gudipativenkatasai@gmail.com

²Department of EIE, SRM University, Chennai 603203, Tamil Nadu, India; vimlala@yahoo.co.in

³Department of ECE, SRR Engineering College, Chennai 603103, Tamil Nadu, India; fence_123@yahoo.co.in

Abstract

Objectives: This paper deals with a new design approach for achieving reconfigurable function in Microstrip Patch Antennas.

Methods/Analysis: Initially, the antennas are designed on three independent substrates for three individual resonant frequencies such as 2.45GHz (Wi-Fi, Bluetooth, and RF-ID), 5.5GHz (Wi-Fi, WLAN, and Wi-Max) and 7.5GHz (Indoor UWB wireless applications, Satellite and Marine Radar) using line feed technique for various wireless communications. And then, a new frequency reconfigurable rectangular Microstrip Patch Antenna is designed with three patches which are installed on a single substrate using the same feeding technique, where RF power is fed directly to the center patch. The integration of patches on the substrate is made possible with RF switches. **Findings:** The performance parameters such as return loss, bandwidth and radiation pattern of the reconfigured antenna were measured based on the RF switch on/off conditions.

Applications/Improvements: Based on the return loss and bandwidth, the performances of both the reconfigurable and non-reconfigurable antenna designs are compared, tabulated and presented using ANSOFT HFSS 13.0.

Keywords: HFSS, Microstrip Patch Antenna, Radiation Pattern, Return Loss, Wireless Applications

1. Introduction

The popularity of micro strip patch antenna has extensively grown in wireless communication and applications. This is because of its advantages which are low profile and light weight. The fact that it can be easily integrated with any electronics circuits plays a huge role in demand of micro strip patch antenna. These antennas have been widely used in various applications such as wireless applications (Wi-Fi, WiMAX, Bluetooth, WLAN, etc), military, GPS. Multifunctional systems depend on several antennae and RF components combination. The possibility of shortcomings such as interference, cost, maintainability, reliability, weight, etc., increases as the number of components required for a system increases.

The solutions to problems about supporting multiple functions in a single antenna unit by supporting more than one frequency or radiate in different patterns, etc is provided by multifunctional antennae¹.

The applications operating within a frequency of 7.5GHz, 5.5GHz and 2.45GHz respectively are handled by the proposed patch antennae. Though there are many feeding techniques, the proposed antenna is employed only with line feed technique. Therefore, the necessary excitation is provided by the micro strip feed line connecting the central patches to a lumped port so that it can operate at its single operational frequency. The radiating patch size and operational frequency are inversely proportional. Thus for higher frequencies, the patch is

*Author for correspondence

considerably small and for lower frequencies, the size of the radiating patch is large²⁻⁴.

2. Micro Strip Patch Antenna Design

Micro strip Patch antenna is considerably small and therefore known as a low profile radio antenna. It is mounted on a flat surface. The radiating patch and the ground plane are on either side of the dielectric substrate. The patch constitutes of various conducting materials such as gold or copper which are shape independent⁵. The antenna's radiation is dependent on the electric fringing fields which are between the edges of the conductor element and the ground plane behind it. The various antenna properties such as dielectric constant (ϵ_r), height (h) of the substrate, the patch dimensions and the frequency are responsible for antenna's radiation⁶. The single band micro strip patch antenna is not generally frequency reconfigurable and thus operates at a single frequency. In this paper, Perfect Electric Conductor (PEC) and Rogers RT/duroid 5880 are the materials used for radiating patch and substrate respectively. The ground plane is also made up of PEC which is on the other side of the substrate⁷.

2.1 HFSS Designs for Non-reconfigured Micro Strip Patch Antenna Structures

- Initially separate single patch antennas were designed for each different frequency.
- Followed by a novel design approach was adopted to design a single reconfigurable patch antenna operating at each of the three frequencies, which would achieve reconfiguration using ideal RF switches.

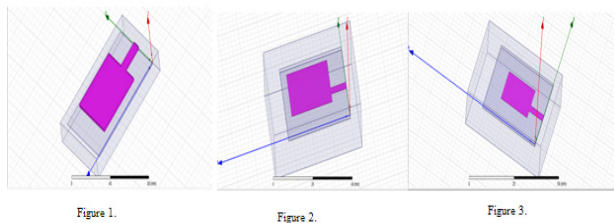

Figure 1. HFSS design for 2.45 GHz micro strip patch antenna. **Figure 2.** HFSS design for 5.5GHz micro strip patch antenna. **Figure 3.** HFSS design for 7.5 GHz micro strip patch antenna.

2.2 Novel Frequency Reconfigurable Rectangular Micro Strip Patch Antenna

The proposed structure of frequency reconfigurable micro strip patch antenna is shown in Figure 4.

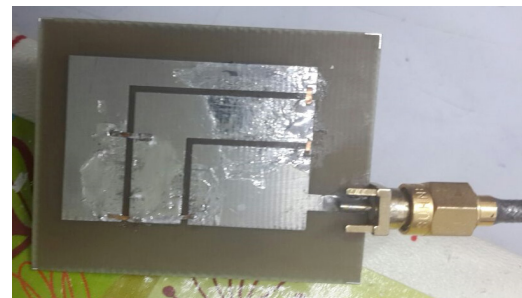
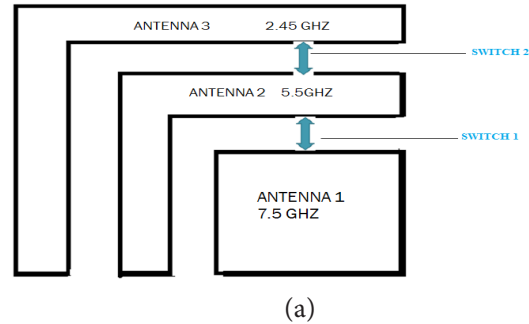

Figure 4. Novel rectangular frequency reconfigurable micro strip patch antenna (a) Before fabrication (b) After fabrication.

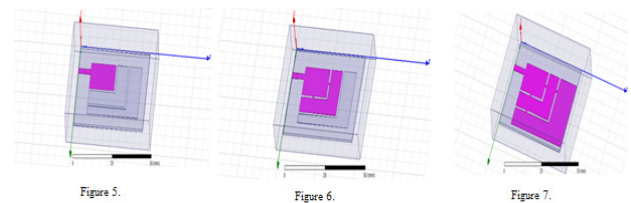

Figure 5. Antenna operating at frequency of 7.5 GHz when no switch is connected. **Figure 6.** Antenna operating at frequency of 5.5 GHz when switch 1 is fixed between inner and middle patches. **Figure 7.** Antenna operating at frequency of 2.45 GHz when both switch 1 and 2 are used.

This proposed novel antenna structure has been designed and simulated using ANSOFT HFSS software operates according the switch positions with three different frequencies. When no switches are fixed between the slots, only the inner centre patch is connected to the line feed and it will be excited directly so that the antenna

operates at 7.5 GHz. When the first two patches (inner patch and middle patches) are connected via RF switch 1(PEC stub lines are used instead of RF switches) the total antenna structure acts as a 5.5 GHz operating frequency antenna. When both switch 1 and switch 2 are connected to their nearby patches the antenna acts as a 2.45 GHz antenna ².

3. Simulation Results and Discussion

The above designed antennae have been modelled at design frequencies of 2.45GHz, 5.5GHz, and 7.5GHz respectively. The resultant parameters which were analyzed are return loss and radiation pattern for each of the configuration of the designed antennae's. An efficient antenna would have a minimum value of -10dB Return loss i.e., 90% of the signal is absorbed and 10% is reflected back. The resultant return loss values for the three antennae are shown:

Frequency vs. Return Loss Graph of Non-frequency Reconfigurable Antenna at 7.5/5.5/2.45GHz

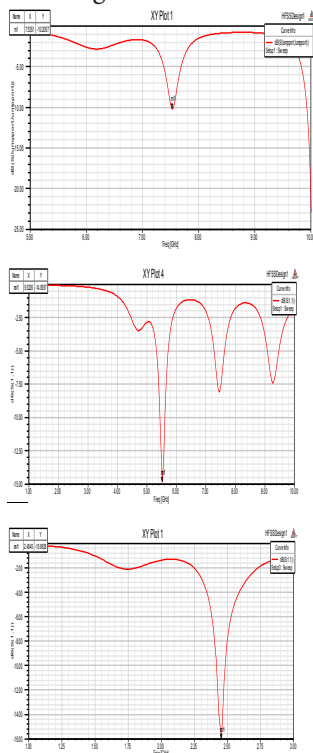

Figure 8. Frequency vs. Return Loss at 7.5 GHz. Return loss = -10.2057 dB. Figure 9. Frequency vs. Return Loss at 5.5 GHz. Return Loss = -14.83 57 dB. Figure 10. Frequency vs. Return Loss at 2.4545 GHz. Return loss = -15.9828 dB.

- From Figure 8. Return loss graph indicates that the antenna shows a return loss of -10.2057 dB at 7.5351GHz. Bandwidth at higher frequency f_2 is 7.5551GHz and lower frequency f_1 is 7.5251GHz. So the bandwidth of the antenna calculated at -10dB is 0.03GHz. And also it is concluded that the return loss at 7.5 GHz is -10.2067 dB.
- From Figure 9. Return loss graph indicates that the antenna shows a return loss of -14.8357 dB at 5.5226 GHz. Bandwidth at higher frequency f_2 is 5.6131GHz and lower frequency f_1 is 5.4322GHz. So the bandwidth of the antenna calculated at -10dB is 0.1809 GHz. It is concluded that the return loss at 5.5 GHz is -14.8357 dB.
- From Figure 10. Return loss graph indicates that the antenna shows a return loss of -15.9828dB at 2.4545GHz. Bandwidth at higher frequency f_2 is 2.4747GHz and lower frequency f_1 is 2.4141GHz. So the bandwidth of the antenna calculated at -10dB is 0.0606GHz. It is known that the return loss at 2.45 GHz is -15.982dB.

Radiation Pattern Graph of the Non-frequency Reconfigurable Antenna at 2.45/5.5/7.5GHz Frequencies

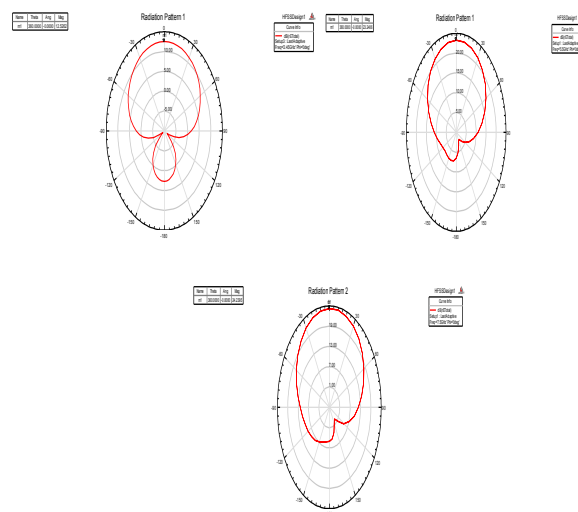

Figure 11. Radiation Pattern of antenna when resonating at 2.45GHz. Figure 12. Radiation Pattern of antenna when resonating at 5.5GHz. Figure 13. Radiation Pattern of antenna when resonating at 2.45GHz.

From the radiation pattern figures (Figures 11, 12 and 13), designed Microstrip patch antennas for 2.45GHz, 5.5GHz and 7.5GHz are radiating their maximum energy normal to the patch surface, giving linear polarization for wireless applications^{2,8}.

Frequency vs. Return Loss Graph of Frequency Reconfigurable Antenna (Simulated Results)

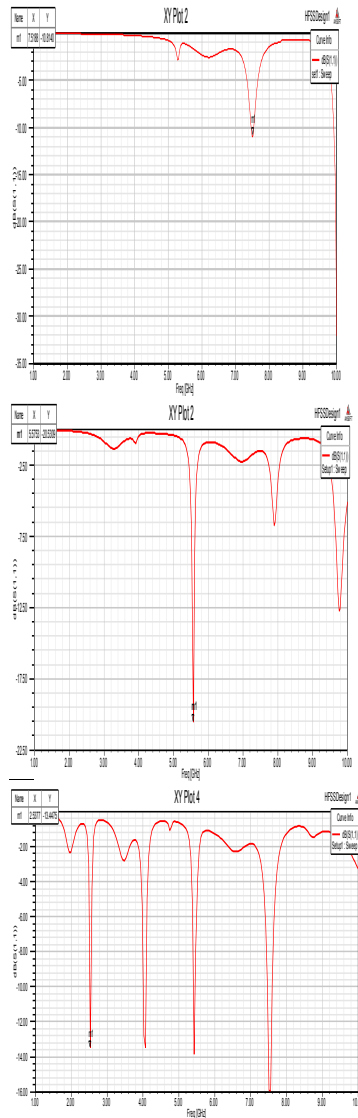

Figure 14. Frequency vs. Return Loss at 7.5 GHz when no switch is connected. Return loss = -10.814 dB. **Figure 15.** Frequency vs. Return Loss at 5.5 GHz when switch is connected. Return Loss = -20.5308 dB. **Figure 16.** Frequency vs. Return Loss at 2.45 GHz when switch 1 and switch 2 are connected. Return loss = -13.45 dB.

- From Figure 14. Return loss graph indicates that the antenna shows a return loss of -10.814 dB at 7.5188GHz. Bandwidth of the antenna calculated at -10dB is 0.067GHz. And also it is concluded that the return loss at 7.5 GHz is -10.814 dB, since no switch is closed, inner patch is alone excited.

- From Figure 15. Return loss graph indicates that the antenna shows a return loss of -20.5308 dB at 5.5753 GHz. Bandwidth of the antenna calculated at -10dB is 0.0848GHz. It is concluded that the return loss at 5.5 GHz is -20.5308 dB, since switch1 is closed, exactly first two segments get integrated together and act as a single patch exhibiting the configuration of 5.5GHz patch antenna.
- From Figure 16. Return loss graph indicates that the antenna shows a return loss of -13.4475 dB at 2.5377 GHz. Bandwidth of the antenna calculated at -10dB is 0.113GHz (summation of bandwidth offered by “return loss at -10 dB” of 2.5GHz, 4.07GHz, and 5.42GHz and 7.5GHz centre frequencies). And it also is concluded that the return loss at 2.45 GHz is -13.982dB, since switch 1 and switch 2 are closed exactly all the three segments get integrated together and act as a single patch exhibiting the configuration of 2.45GHz patch antenna.

From the above three stages of operations it is observed that at each stage the antenna is operational only at a particular frequency 7.5 GHz, 5.5 GHz and 2.45 GHz respectively. With this reconfiguration a single antenna can be used for a wide range of applications. This is possible as the bandwidths of each frequency are summed together.

The total Bandwidth of Reconfigurable micro strip patch antenna is the summation of the bandwidth of each individual antenna operating at 2.45/5.5/7.5GHz. So the bandwidth of proposed reconfigurable antenna is 0.2624GHz, from the Table 1 shown below. By this it can be concluded that the bandwidth of non – reconfigurable antenna is lesser than that of reconfigurable antenna. Hence the bandwidth of Reconfigurable antenna is optimized and proving narrow banding problems can be avoided.

3.1 Performance Comparison

The simulated results of the reconfigured patch antenna were generated and the return loss parameter has been calculated. The return loss comparison and bandwidth comparison of three non-reconfigured antennas and single reconfigured patch antenna is tabulated and mentioned in Table 1.

Table 1. Bandwidth comparison

Operating frequency (GHz)	Frequency Reconfigurable antenna – Band width (GHz)	Single or Non Reconfigurable antenna – Bandwidth (GHz)
2.45	0.113	0.0606
5.5	0.0848	0.1809
7.5	0.067	0.03

From Table 1, the maximum bandwidth offered by a single rectangular Microstrip patch antenna is 0.1809 GHz, whereas the new proposed frequency reconfigurable rectangular Microstrip patch antenna (three different patch segments integrated on to a single substrate with single feed) is capable of providing greater bandwidth nearly around 0.113GHz and also the total bandwidth is 0.2648 GHz (summation of 0.113GHz, 0.0848 GHz and 0.067 GHz)².

Table 2. Return loss comparison

Operating frequency (GHz)	Frequency Reconfigurable antenna – Return loss (dB)	Non-Reconfigurable antenna – Return loss (dB)
2.45	-13.4475	-15.9828
5.5	-20.5308	-14.8357
7.5	-10.8140	-10.2057

From Table 2 return losses were compared shows that both antenna structures are suitable for fabrication since their return losses are below -10dB.

The new proposed frequency reconfigurable Microstrip patch antenna is fabricated (as shown in Figures 8–10) based on the return losses which were observed after the optimized results using ANSOFT HFSS 13.0. The fabricated antennae structure was tested and return losses were measured with various optimized positions of both switches (ideal RF Switches) connected between the rectangular patch segments for 2.45GHz, 5.5GHz and 7.5GHz wireless applications. Antenna testing setup and measured return loss figures are shown below.

During the testing of proposed antenna, both switch 1 and switch 2; ideal RF switches (stub lines), are used

to combine all three rectangular patch segments and also their positions are adjusted for the measurement of return losses. Return losses measured are -28.85dB at 2.4225GHz, -32.32dB (see Figure 17.) at 2.4302GHz, -29.92dB at 2.4729GHz and -27.37dB at 2.4762GHz proving that the designed and fabricated antennae is applicable for 2.45GHz wireless applications².

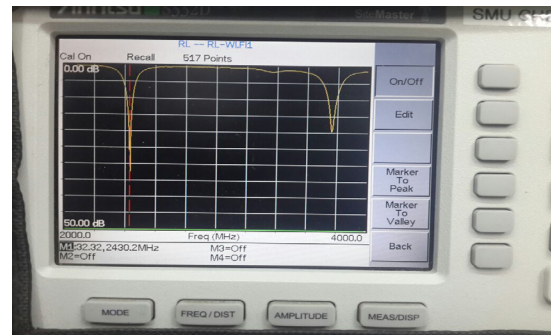
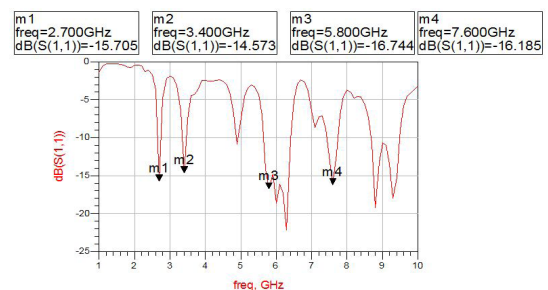
**Figure 17.** Proposed antenna testing setup;**Figure 18.** Return loss measured -32.32dB at 2.4302GHz.**Figure 19.** Measured return loss vs. frequency graph

And also another set of return losses are measured with respect to various positions of the switches as shown in above figure where the observed return losses are -15.705 dB at 2.700GHz, -14.573 dB at 3.400GHz, -16.744 dB at 5.800GHz and -16.185 dB at 7.600GHz respectively.

4. Conclusion

Hence a new design approach of simple frequency reconfigurable rectangular Microstrip patch antenna structure using line feed technique on a single dielectric substrate with ideal RF switches has been designed and tested for 2.45GHz, 5.5GHz and 7.5GHz centre operating frequencies². Ideal RF switches are used for reconfiguration purpose⁹. Here the performance of proposed antenna structure is analyzed in terms of return losses which are determined based on optimizing switch positions and the results are proving that the proposed antenna structure is suitable for various wireless applications compared to that of the existing rectangular non-reconfigurable design that is, only one single radiating patch operates at three different frequencies thus giving the advantage of multitasking^{2,10} i.e. it allows the single antenna structure to be used to tune simultaneously 2.45GHz frequency (for Wi-Fi, Bluetooth and RF-ID), 5.5GHz frequency (for Wi-Fi, personal WLAN, and Wi-Max) and 7.5GHz frequency (for Satellite and Marine Radar) applications. And also this design approach provides a better alternative for multiple indoors and outdoors applications which require a low profile multitasking antenna that takes up less space and cost efficient^{11,12}.

This same new design approach for simple rectangular Microstrip patch antenna structure would provide better alternative for multiple indoor and outdoor wireless applications^{8,12}.

5. References

1. Karthiga M, Samuel SJ. Emergency spybot to detect and to help human in disaster. *International Journal of Applied Engineering Research*. 2014; 9(14):2487–94.
2. Geetha BT, Srinath MV, Perumal V. Energy efficient throughput maximization for wireless networks using piece wise linear approximation. *Indian Journal of Science and Technology*. 2015 Apr; 8(7):683–8. DOI: 10.17485/ijst/2015/v8i7/62866.
3. Balanis, AC. *Antenna theory: Analysis and design*, hoken, John Wiley & Sons Inc.; 2005. p. 811–82.
4. Grag R, Bhartia P, Bahl I, Ittipiboon A. *Microstrip antenna design handbook*, Artech House; 2001. p. 845.
5. Kumar KP, Ray G. *Broadband microstrip antennas*, 1st edition, Artech House Publishers, Norwood; 2003.
6. Kumar A, Kaur J, Singh R. Performance analysis of different feeding techniques. *International Journal of Emerging Technology and Advanced Engineering*. 2013 Mar; 3(3):884–90.
7. Tripathi RK. Dual frequency wideband rectangular microstrip patch antenna for wireless application systems, M.Tech Thesis, Thapar University, Patiala; 2011 Jun.
8. Kapur V, Bodhaye N, Marotkar D, Marotkar S. Study of reconfigurable multiband micro strip patch antenna for wireless communication. *International Journal Of Innovative Research In Electrical, Electronics, Instrumentation And Control*. 2013 Aug; 1(5).
9. Rebeiz GM, Muldavin JB. *IEEE Microwave Magazine*. 2001 Dec; 4:59–71.
10. Zhi-Anzheng, Qing-Xinchu, Zhi-Hongtu. Compact band rejected UBW slot antennas inserting with an resonators. *IEEE Transactions on Antennas and Propagation*; 2010. p. 390–7.
11. Grag R, Bhartia P, Bahl I, Ittipiboon A. *Microstrip antenna design handbook*, Artech House; 2001. p. 845.
12. Jegan G, Juliet AV, Singhvi H. A novel design approach of reconfigurable patch antenna for wireless application. *Applied Mechanics and Materials*. 2013; 336–338:1935–8.