

# Analytical Review on MLI based Active Power Filter to Reduce Harmonics for Improvement in Power Quality

Ginga Madhu and Pardeep Mittal\*

Department of Electronics and Electrical Engineering, Lovely Professional University Jalandhar, Phagwara – 144411, Punjab, India; gingamadhu@gmail.com, pkm.gagi@gmail.com

## Abstract

**Background:** Poor power quality is serious problem in power system. The introduction of harmonics in power system makes its quality poor. This paper describes the analytical study of different topologies of Multi Level Inverter, switching techniques used for MLI, different Active Power Filters and their control strategies for compensating the harmonics. **Method:** Multi Level Inverter based shunt Active Power Filter has been used to reduce the amount of harmonics which enhances the power quality in distributed power system. **Findings:** Conventional inverters produce more harmonics in power system which can be reduced with the use of active power filters. Multi Level Inverter (MLI) in conjunction with Pulse Width Modulation reduces the harmonic contents and achieves sinusoidal signals without add-on circuitry. The output voltage provided by MLIs has small voltage steps, which results in good power quality and low harmonic components. The system is simulated using MATLAB/SIMULINK platform. **Improvements:** Line current distortion caused by the nonlinear loads and power electronic devices can be efficiently neutralized by shunt Active Power Filter both in transient and distortion voltage conditions.

**Keywords:** Active Power Filter, Multi Level Inverter, Power Quality, Pulse Width Modulation (PWM)

## 1. Introduction

The impact of power quality in low voltages and high voltages is much more pronounced now-a-days. Due to its impact on equipment's (laptops batteries, chargers and on electronic devices) life cycle and in case of high voltages transmission line sag, swell and voltage dip which leads to increase in the economic aspects of both consumer end and industrial side. These power quality effects are caused due to the distorted sinusoidal wave also called harmonics.

In earlier to suppress these harmonics passive filters are used. In the advancement of Active Power Filters and power electronic convertors made passive filter to very less usage. The main disadvantages of these passive filters are many so: The filtering requirement depends on the source impedance which is not known exactly. In between filter and power system there will be parallel resonance<sup>1</sup> and

with aging of the components there will be de-tuning in frequency. These drawbacks of passive filters are overcome by Active Power Filters and made the passive filters to be restricted to very few applications. In case of APF, A high level of  $dv/dt$  appears in commutation for medium voltage. With the advancement of MLI (Multi Level Inverter) in high voltage usage made to be pronounced high in power electronics mainly in reactive power compensation and drive applications<sup>2</sup>. In earlier to suppress these harmonics passive filters were used. Conventional passive filters are nothing but tuned LC filters. The main objective of these filters is to tune the frequency of the filter to desired harmonic elimination. Taking into account of these drawbacks and economic aspects, scientists started experimenting on active filters and in the advancement of power electronic devices give a new vision to the power system. At present most of the Active Power Filters are

\*Author for correspondence

equipped with voltage source converter mainly Multi Level Inverters.

## 2. Multi Level Inverter and their Topologies

Multi Level Inverters are mainly classified into three types<sup>3,4</sup>:

- Diode clamped MLI.
- Flying capacitor MLI.
- Cascaded H-Bridge MLI.

Table 1 shows the device requirement in 3-phase MLI. Recently new topologies of MLI have been developed.

- Static switch capacitance MLI
- Modular MLI

Static switch capacitance is having some limitations in its power ratings and it is has an advantage of less number of switching devices compared to same voltage levels produced in diode, flying and cascaded Multi Level Inverter. Increase in the sensor requirement when compared to capacitor voltage control. In this voltage balance capacitor technique it involves three steps. In the first step balance of the supply makes usage of lesser sensor i.e. three PI controllers for five level APF. In capacitor voltage balance technique<sup>2</sup>, the control is done by individual capacitor voltages which leads to current is made by voltage capacitor control technique. In the second step is to maintain symmetrical loading of capacitors. This can be done by switching technique of provided to the MLI (Multi Level Inverter).

The switching to the MLI is provided by either of these CPS-PWM, level phase shift PWM, Space Vector PWM.

The symmetrical loading of the capacitor can be done by any of following three techniques:

- Capacitor voltage control as a harmonic current extraction.
- Capacitor voltage balance.
- Predictive current control.

In capacitor voltage control technique the power balance can be done in a way that the difference of supply and load power should be compensated by capacitor instantaneously. Power balance is done by controlling the capacitor voltages using PI (Proportional Integral) controllers. This technique has many advantages like sensor requirement and burden in computational is less. In this the sensor requirement is for supply current for load and Active Power Filter doesn't require which). And the third step is to interchange the signals from gate driver circuit to the control circuit. In the third control technique, the reference voltages are estimated by using the reference values of supply voltage, current and Point of Common Coupling (PCC). These estimated output voltages from the inverter are used for switching the inverter.

## 3. Filter Classification and their Control Strategies

Filters are classified as passive, active and Hybrid filters. As passive filters are having more disadvantages and in the advancement in power devices, Active Power Filters are most likely used. Hybrid filters are nothing but the combination of APF (Active Power Filter) and passive filter. Shunt active filter is used for current controllability. It injects current harmonics in the line which are equal in magnitude and opposite in direction. The reference

**Table 1.** Device requirement in a 3-phase Multi Level Inverter

MLIs	No. of Switching device	Isolated DC supply	No. of Clamping Diodes	No. of Floating Capacitor	No. of Level capacitor
Diode Clamped MLI (Multi Level Inverter)	$6*(m-1)$	0	$3(m-1)*(m-2)$	0	$(m-1)$
Flying Capacitor MLI (Multi Level Inverter)	$6*(m-1)$	0	0	$3(m-1)*(m-2)/2$	$(m-1)$
Cascaded H-Bridge MLI (Multi Level Inverter)	$6*(m-1)$	$3*(m-1)/2$	0	0	$3(m-1)/2$

current is fed to the inverter circuit from which the output AC current is feed to line through the inductance.

Series Active Filter compensates voltage harmonics and improves voltage quality and maintains voltage constant. Figure 1 shows shunt active filter for power line conditioning<sup>5</sup>. Series Active Filter is used to mitigate the voltage harmonics of non-linear source and/or load to improve voltage quality of non-linear load/source and done by injection of opposite polarity harmonic voltage with help of series injection transformer. The Series Active Filter also capable of mitigating voltage and/or current harmonics due to source load and/or source<sup>6</sup>.

## 4. Control Strategies of Active Power Filter

### 4.1 Generating Current Reference using P-Q Theory

Instantaneous Real and Reactive power theory is used to control the shunt active filter. This theory is used to measure instantaneous current and voltage from that compensation to voltage and current harmonics are provided. The p-q theory performs a Clarke transformation matrix. In which stationary reference frame coordinates a-b-c axis's are transferred into orthogonal coordinates  $\hat{a}\text{-}\hat{b}$  axis's. In stationary reference frame each vector are separated by 120 degree and in orthogonal reference frame  $\hat{a}\text{-}\hat{b}$  axis's are having a phase shift of 90 degree.

The instantaneous source voltages  $v_{sa} v_{sb} v_{sc}$  are transformed into the  $\hat{a}\text{-}\hat{b}$  coordinate's voltage  $v_{\alpha} - v_{\beta}$ ,

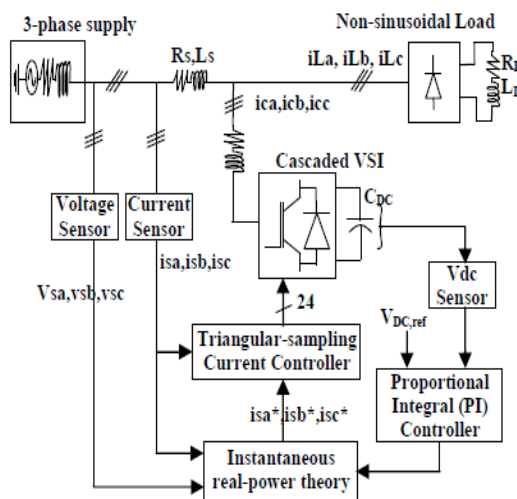

Figure 1. Shunt active filter for power line conditioning<sup>6</sup>.

by Clarke transformation. The instantaneous current are transformed in to  $\hat{a}\text{-}\hat{b}$  as follows:

$$\begin{pmatrix} i_{\alpha} \\ i_{\beta} \end{pmatrix} = \sqrt{\frac{2}{3}} \begin{pmatrix} 1 & -\frac{1}{2} & -\frac{1}{2} \\ 0 & \frac{\sqrt{3}}{2} & -\frac{\sqrt{3}}{2} \end{pmatrix} \begin{pmatrix} i_{sa} \\ i_{sb} \\ i_{sc} \end{pmatrix} \quad (1)$$

In a similar way the instantaneous voltage equations are transformed into  $\hat{a}\text{-}\hat{b}$  coordinates.

$$\begin{pmatrix} v_{\alpha} \\ v_{\beta} \end{pmatrix} = \sqrt{\frac{2}{3}} \begin{pmatrix} 1 & -\frac{1}{2} & -\frac{1}{2} \\ 0 & \frac{\sqrt{3}}{2} & -\frac{\sqrt{3}}{2} \end{pmatrix} \begin{pmatrix} v_{sa} \\ v_{sb} \\ v_{sc} \end{pmatrix} \quad (2)$$

### 4.2 Real Power Calculations

The instantaneous real power taken from the  $\alpha\text{-}\beta$  axes of the current and voltage can be described as:

$$P_{ac} = v_{\alpha} i_{\alpha} + v_{\beta} i_{\beta} \quad (3)$$

This instantaneous power ( $p_{iac}$ ) is allowed to pass to first order LPF for discriminate the higher order harmonic components. The DC power loss is derived from comparing the DC-bus capacitor voltage of the cascaded inverter with the desired reference voltage. The PI controller describes the dynamic response of the DC-bus capacitor voltage<sup>5</sup>.

$$P_{dc(loss)} = [v_{dc,ref} - v_{dc}] \left[ k_p + \frac{k_i}{s} \right] \quad (4)$$

The instantaneous power is the summation of  $P_{ac}$  and  $P_{dc}$  loss

u

$$P = P_{ac} + P_{dc(loss)} \quad (5)$$

The instantaneous current obtained from the transformation ( $\alpha\text{-}\beta$ ) axis's having two components reactive and real power loss. In this approach only real power losses are computed and reactive power (Q) component is assumed to be zero<sup>6</sup>.

$$\begin{pmatrix} i_{c\alpha} \\ i_{c\beta} \end{pmatrix} = \frac{1}{v_{\alpha}^2 + v_{\beta}^2} \begin{pmatrix} v_{\alpha} & v_{\beta} \\ v_{\beta} & -v_{\alpha} \end{pmatrix} \begin{pmatrix} p \\ 0 \end{pmatrix} \quad (6)$$

The  $\alpha$ -axis of the instantaneous active current,

$$i_{c\alpha} = \frac{v_{\alpha} p}{v_{\alpha}^2 + v_{\beta}^2} \quad (7)$$

The  $\beta$ -axis of the instantaneous active current,

$$i_{c\beta} = \frac{v_{\beta} p}{v_{\alpha}^2 + v_{\beta}^2} \quad (8)$$

The instantaneous powers  $P(t)$  is given by,

$$P(t) = v_{c\alpha}(t)i_{c\alpha}(t) + v_{c\beta}(t)i_{c\beta}(t) \quad (9)$$

In the above function  $P(t)$  substitute the orthogonal currents  $i_{c\alpha}$  and  $i_{c\beta}$

$$P(t) = v_{\alpha}(t) \left( \frac{v_{\alpha}p}{v_{\alpha}^2 + v_{\beta}^2} \right) + v_{\beta}(t) \left( \frac{v_{\beta}p}{v_{\alpha}^2 + v_{\beta}^2} \right) \quad (10)$$

The instantaneous real power produces the required currents which compensates the harmonics of distorted line current and reactive power<sup>5</sup>.

### 4.3 Generating Current Reference using Average Power Method

This technique gives improved results even distortion in the supply voltage. A PLL based unit vector template is used for getting fundamental voltages. The main voltage waveform is having fundamental component and distortion component. The unit vector template can be obtained by multiplying the input voltage with the gain and it is passed through a PLL (Phase Lock Loop) for synchronization of signals.

The reference value of peak current required to provide the losses in APF is  $I_{sm}^*$  and obtained by comparing the reference voltage and actual capacitor voltage. The actual capacitor voltage is average voltage of capacitors used in each phase. The estimation of  $I_{sm}^*$  is shown in the below figure. The total peak reference source current  $I_{sm}^*$  is computed as sum of these two components. The three phase instantaneous reference source currents ( $i_{sa}^*, i_{sb}^*, i_{sc}^*$ ) are computed by multiplying peak value  $I_{sm}^*$  with unit current templates ( $u_{sa}^*, u_{sb}^*, u_{sc}^*$ ) derived from sensed bus voltages ( $v_a, v_b, v_c$ )<sup>1</sup>. The desired references of the APF currents ( $i_{ca}^*, i_{cb}^*, i_{cc}^*$ ) are computed by taking the difference between the three phase instantaneous reference source currents ( $i_{sa}^*, i_{sb}^*, i_{sc}^*$ ) and actual source currents. ( $i_{sa}, i_{sb}, i_{sc}$ )

$$\begin{aligned} i_{ca}^* &= i_{sa}^* - i_{sa} \\ i_{cb}^* &= i_{sb}^* - i_{sb} \\ i_{cc}^* &= i_{sc}^* - i_{sc} \end{aligned} \quad (11)$$

The switching signals can be generated by comparing the reference currents with triangular carrier and the switching frequency can be determined by triangular carrier wave.

## 5. Analysis of Simulation Results

Analysis on the results of cascaded Multi Level Inverter switching with Carrier phase shift PWM for active power line conditioning is done and their simulations are performed in MATLAB SIMULINK. The system parameters are; System frequency is 50 Hz; line to line source voltage is 440 V; Source impedance of LS is 1 mH; Filter impedance of  $R_c, L_c$  is 0.1  $\Omega$ ; 1 mH; diode rectifier  $R_L, L_L$  load: 20  $\Omega$ ; 100 mH.

DC side capacitance ( $C_{DC}$ ) is 2100  $\mu\text{F}$ ; Reference voltage ( $V_{DC, \text{ref}}$ ) is 150 V; Power devices are IGBTs with diodes. Simulation result of the six-pulse rectifier load current before compensation is presented<sup>5</sup> in Figure 2. It shows the load current consists of fundamental and harmonic components. The reference fundamental current is detached from the distorted current using the instantaneous real- power compensator as shown in Figure 3 and Figure 4.

The cascaded Multi Level Inverter based Active Power Filter must provide the harmonic filter current or compensation current as  $I_c(t) = I_l(t) - I_s(t)$ .

From the simulation results it is shown that source current after compensation is sinusoidal which is represented in Figure 5. These simulation results prove that the proposed APF system have a good compensation effect at low device switching frequency which is an important aspect for high voltage applications<sup>7,8</sup>.

The DC-bus capacitors voltage of the cascaded Multi Level Inverter is controlled by PI-controller that is shown in Figure 6. It serves as an energy storage element to supply real power to operate three-phase cascaded Multi Level Inverter<sup>5</sup>.

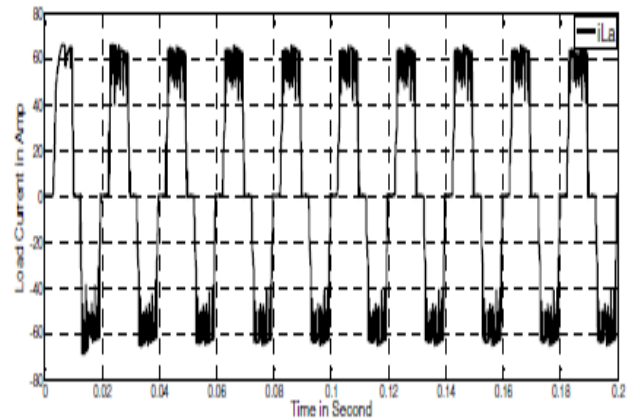
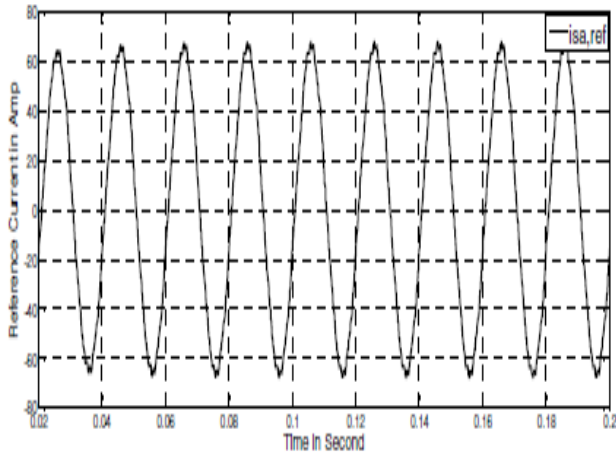
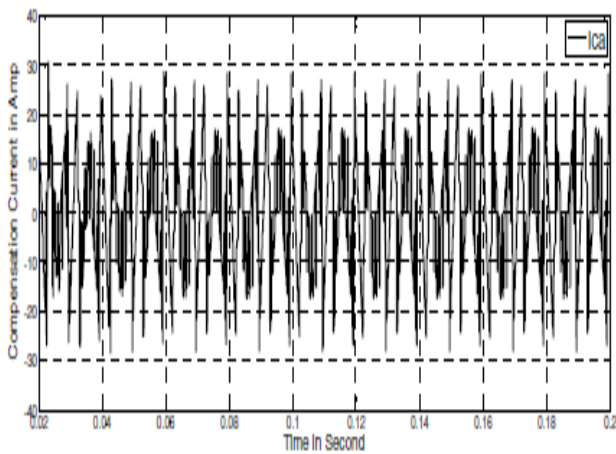

Figure 2. Before compensation, load or source current.



**Figure 3.** Reference current extracted using real power theory.



**Figure 4.** Compensation current from Active Power Filter (APF).

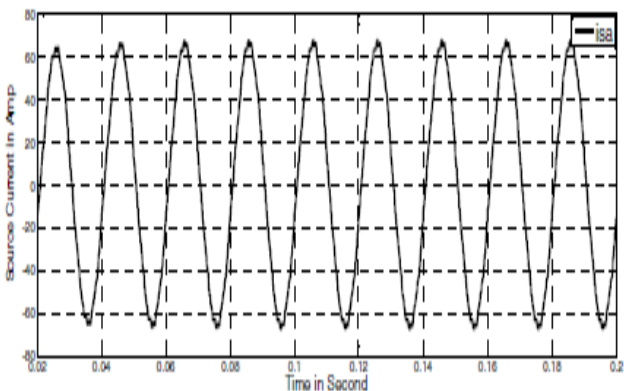

**Figure 5.** Source current after compensation.

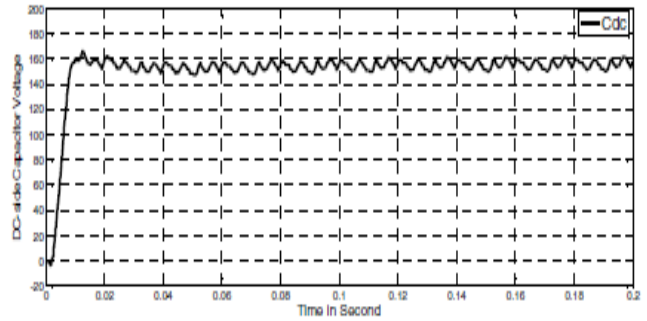

**Figure 6.** DC bus capacitor voltage of the cascaded inverter.

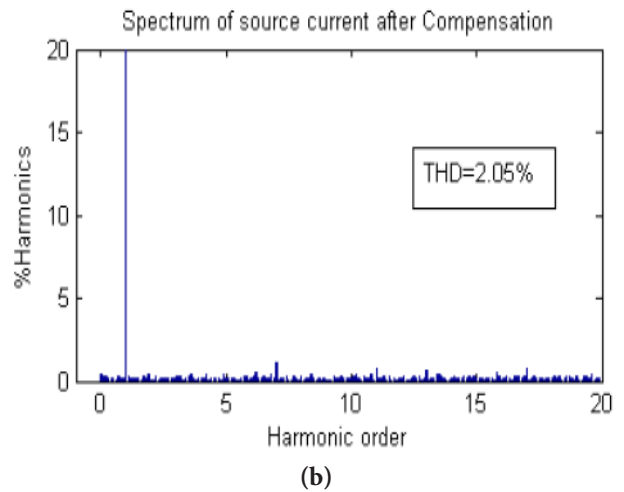
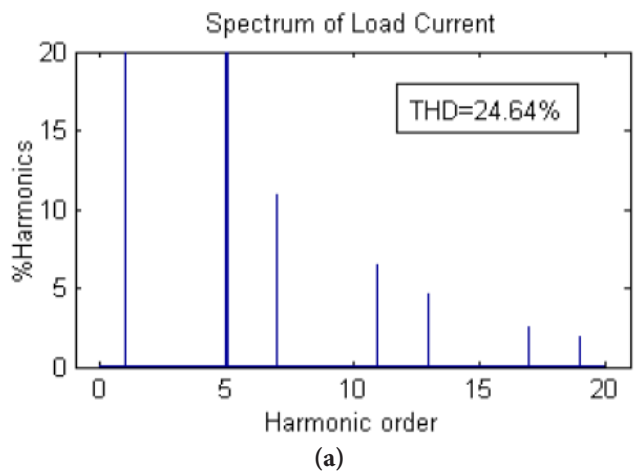

**Figure 7.** (a) Load current or source without active filter. (b) Source current after compensation.

Figure 7(a) shows source or load current without active filter (THD 24.64%) and Figure 7(b) shows source current after compensation (THD 2.05%) which is limited to IEEE-519 Standard.



## 6. Conclusion

A review on improvement of power quality with MLI used in Active Power Filter (APF) and their different control strategies for filter and capacitor balance voltage methods are described. In this a cascaded five level MLI with CPS-PWM is used in Active Power Filter (APF). A 2-level based Active Power Filter without transformer was applicable to low voltage distribution networks. Line current harmonic distortion can be reduced below 3% by using shunt Active Power Filter. The performance can be further improved by using Artificial Neural Network techniques (ANN) and fuzzy logic controllers and FACTS devices with more number of levels.

## 7. References

1. Waware M, Agarwal P. Comparison of control strategies for Multi Level Inverter based Active Power Filter used in high voltage systems. IEEE 2010 Joint International Conference on Power Electronics Drives and Energy Systems (PEDES); New Delhi. 2010 Dec 20-23. p. 1–6.
2. Homero M, Victor C, Jorge P. A hybrid Multi Level Inverter for shunt Active Filter using space-vector control. 2004 35th Annual IEEE Power Electronics Specialists Conference; Aachen, Germany. 2004 Jun 20-25. p. 3541–6.
3. Reddy DM, Gowrimanohar T. Optimal hybrid modulation scheme for 11-level CMC based DSTATCOM for power quality improvement. 2nd International Conference on Current Trends in Engineering and Technology, ICCTET'14; Coimbatore. 2014. p. 296–303.
4. Ramesh Babu S. Comparative analysis of cascaded Multi Level Inverter for phase disposition and phase shift carrier PWM for different load. Indian Journal of Science and Technology. 2015 Apr; 8(S7):251–62.
5. Massoud AM, Finney SJ, Cruden AJ, Williams BW. Three-phase, three-wire, five-level cascaded shunt Active Filter for power conditioning using two different space vector modulation techniques. IEEE Transactions on Power Delivery. 2007 Oct; 22(4):2349–61.
6. Karuppanan P, Mahapatra KK. Cascaded Multi Level Inverter based Active Filter for power line conditioners using instantaneous real-power theory. IEEE India International Conference on Power Electronics; New Delhi. 2011.
7. Parthasarathy S, Karthickkumar SA, Rahini S. Enhancement of output voltage quality of Multi Level Inverter using Series Active Filter. IEEE 2015 International Conference on Circuit, Power and Computing Technologies [ICCPCT]; Nagercoil. 2015. p. 1–9.
8. Waware M, Agarwal P. Performance investigation of Multi Level Inverter based Active Power Filter in distorted high voltage supply system. 2010 IEEE International Conference on Sustainable Energy Technologies (ICSET); Kandy. 2010 Dec 6-9. p. 1–6.