

FPGA Implementation by using XBEE Transceiver

B. Murali Krishna, M. Siva Kumar, J. Rajesh*, Syed Inthiyaz, J. Mounica, M. Bhavani and Choti Nikitha Adidela

Department of Electronics and Communication Engineering, KL University, Vijayawada – 520002, Andhra Pradesh, India; muralikrishna@kluniversity.in, siva4580@kluniversity.in, syedinthiyaz@kluniversity.in, mounisa4@gmail.com, bhavanimathi.147@gmail.com, chotินิกitha@gmail.com

Abstract

Objective: Generally there are numerous approaches to give security information that is being imparted. However, what if the security is assured irrespective of the hackers are from the noise. The Information Security is essential concern towards each communication system. **Methods/Analysis:** XBee is a PAN technology based on the IEEE 802.15.4 standard. Unlike Bluetooth or wireless USB devices, XBee devices have the ability to form a mesh network between nodes. Meshing is a type of daisy chaining from one device to another. **Finding:** This technique allows the short range of an individual node to be expanded and multiplied, covering a much larger area. This paper describes a design of desired security for data communication by designing standard algorithm for encryption and decryption. The process occur in this module was based on encryption and decryption. The source information is generated by a bit file and this will be encrypted and is sent to destination through XBee modules. The receiving system will check the data and decrypt according to a specific algorithm and displays on the LED. **Applications/Improvement:** The present algorithm is implemented in Verilog HD Land simulated using Xilinx ISE simulator tool. The design is implemented on Xilinx Spartan-3 EFPGA development board. This project has applications in encoding and decoding operations for security purposes.

Keywords: Decryption, Encryption, Spartan 3E FPGA, Verilog HDL, Xgbee, Xilinx ISE Tool

1. Introduction

For the most part, in information transmission we can utilize numerous gadgets like blue tooth, XBee and remote USB devices. This paper describes an outline of powerful security for information correspondence by planning standard calculation for encryption and decoding. XBee makes conceivable totally organized homes where all gadgets can convey and be controlled by a solitary unit¹. It gives system, security and application bolster administrations working on top point of IEEE Works in Personal Area Networks (PAN's) and gadget to-gadget systems connected between little packet gadgets.

These RF modules brought another standard into the DIY remote world due to their prevalent execution and usefulness. The XBee modules work at the 2.4 GHz recurrence which implies littler board and radio wire size. XBee modules can transmit Advanced, PWM, Simple or Serial RS232 flags remotely².

Xgbee contraptions are regularly used as a piece of grid framework structure to transmit data over longer partitions, going data through widely appealing devices to accomplish more blocked off ones. This licenses Xgbee frame works³ to be formed extraordinarily delegated, with no united control or high-control transmitter/recipient prepared to accomplish most of the devices. Any Xgbee device can be tasked with running the framework.

A Full Function Device⁴ (FFD) takes up a part as Skillet organizer; alternate hubs can be Reduced Function Device⁵ (RFDs) or FFDs. In the distributed topology, every gadget can correspond specifically with some other gadget if the gadgets^{6,7} are sufficiently close together to set up a fruitful correspondence join. Any FFD in this topology can assume the part of the Skillet organizer⁸. Xgbee works in the mechanical, exploratory and remedial (ISM) radio gatherings; 2.4 GHz in huge areas accross the globe. The rise of remote interface gadgets made a solid interest for low-information rate short-run remote systems administration.

*Author for correspondence

This prompted the advancement of Xgbee standard, which is an arrangement of new correspondence conventions for remote transmission. The Xgbee standard is created by the Xgbee Alliance which has several part organizations, from semiconductor industry and programming designers to unique gear producers and installers.

Electronic scale⁹ has an extensive variety of use in business and modern territory. It is the up and coming pattern to be widely utilized as a part of numerous measuring applications. The Xgbee is considered for remote communication. The Xgbee innovation¹⁰ gives long battery life, adaptable and simple establishment, low information rate (less than 250 Kbps) and coordinated knowledge for system set-up and message directing.

1.1 Reason and Outline of this Undertaking

The essential objective of this undertaking is to make a XBee remote interface between two FPGAs¹¹. One will go about as a collector; another will go about as a transmitter. The transmitter will have two catches connected to it to give data. Contingent upon which catch is squeezed the accepting PIC will turn its comparing Drove on. In the event that no catches are squeezed the LEDs will stay off¹².

With a specific end goal to fabricate the circuit and firmware important for this instructional exercise we'll need to show signs of improvement comprehension of the XBee modules and how they function. We'll examine them in the hypothesis area. The firmware will be straight forward computerized I/O and in this way shouldn't be for quite some time. So without further adue we should begin¹³.

The PHY layer backings three recurrence groups: A 2.45 GHz band with 16 channels, a 915 MHz band with 10 channels and a 868 MHz band with 1 channel. With the advancement of utilizing Verilog style, this paper will deliver a 35% change is achieved as far as zone and execution contrasted and the fast coordinated circuit equipment depiction dialect (VHDL) usage. The advanced transmitter plan matches hypothetical desire. With the frequencies of 250 kHz and 2 MHz, focal handling unit (CPU) run-time for the reproduction took 42 s.

2. XBee Module

XBee features:

- Power consumption will be low.
- Providing simple protocol and global implementation.
- Having flexibility in network.

- Connecting Hundreds of gadgets per Network¹.

Xgbee is a standard that characterizes an arrangement of correspondence conventions for low-information rate short-run remote systems administration¹³. In numerous Xgbee applications, the aggregate time the remote gadget is occupied with a movement is extremely restricted; the gadget invests a large portion of its energy in a force sparing mode, otherwise called rest mode. Therefore, Xgbee empowered gadgets are fit for being operational for quite a while before their batteries should be supplanted¹⁴.

2.1 Security in Xgbee Communications

In a remote system, the transmitted messages can be gotten by any close-by gadget, including a gate crasher. There are two principle security worries in a remote system. The first is information secrecy. The interloper gadget can increase delicate data by essentially listening to the transmitted messages. Encoding the messages before transmission will take care of the classification issue. An encryption calculation adjusts a message utilizing a series of bits known as the security key and just the proposed beneficiary will have the capacity to recoup the first message. The IEEE 802.15.4 standard backings the utilization of Cutting edge Encryption Standard (AES)¹⁴ to encode their active messages. The second concern is that the gatecrasher gadget might adjust and resend one of the past messages regardless of the possibility that the messages are scrambled. Counting a Message Information Code (MIC) with each friendly casing will permit the beneficiary to know whether the message has been changed in travel. This procedure is known as information validation.

2.2 Transceiver Performance

A handset (transceiver) gives the method for radio correspondence for two hubs. Cases of the obstruct that can be found alongside the radio interface incorporate micro-controllers; memory; simple to-computerized converters or ADCs (for sensor interface); and broadly useful data/yield ports (GPIOs). At the point when the destination gets the sign, the collector circuit will utilize a mix of simple and advanced sifting to uproot the ghostly substance outside the recurrence band of hobby. The commotion is typically displayed as a sign with level force otherworldly thickness. At the point when the sign is separated, the main clamour that matters is the commotion inside of

the recurrence band of hobby. The proportion of the aggregate value in turns from energy to aggregate clamour power inside of the band of hobby is known as the sign to-commotion proportion (SNR).

3. Schematic Overview

The immense thing about these little XBee modules is they deal with all the hard work. As should be obvious underneath both the transmitter and the collector circuits are drop dead straightforward. The principle gadgets utilized as a part of the circuit are the XBee modules, spartan3E and LM317 voltage controller.

From Figure 1, in this schematic section it comprises of two sections internally, those are transmitter and receiver section (as shown in Figures 1 and 2). In the transmitter section, the main parts are powering circuit, clking circuit, FPGA module and the Xgbee module. The powering circuit consists of LM317 voltage regulator, which regulates the voltage according to the desired one. The clking circuit consists of crystal oscillator device, which produces clk frequencies as required for the Xgbee module. Finally Xgbee module recives the information from the FPGA board and transmitted through the antenna to the receiving section.

From Figure 2, in the receiving section reverse operation takes place it means from Xgbee module to LED's operation will takes place. In the transmitter section encryption of data will occurred means encoding operation. Where as in the receiver section decryption operation will takes place means decoding operation.

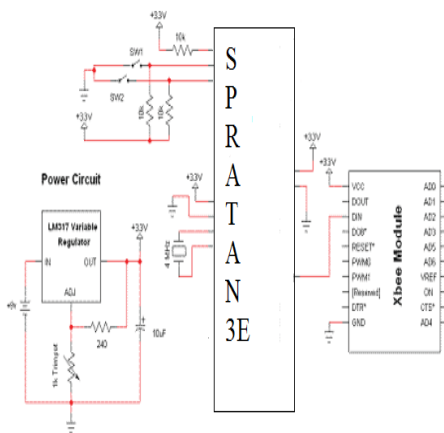

Figure 1. Schematic representation of the transmitter section.

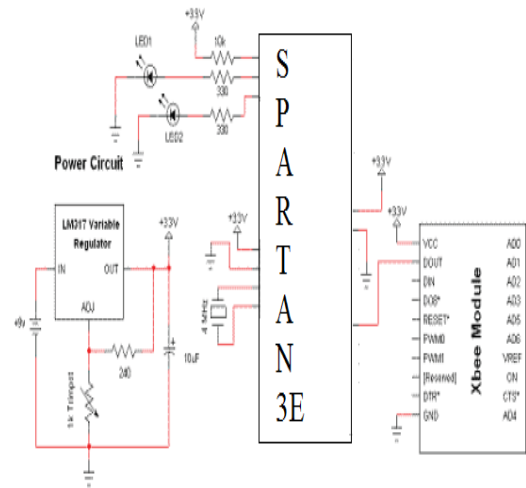

Figure 2: Schematic representation of the receiver section.

3.1 Schematic Specifics

3.1.1 Power Circuit

Both circuits utilize the same straightforward force regulation circuit with the LM317 for +3.3 v reg. A yield capacitor of 10 uF is utilized for commotion separating which helps keeps the yield DC signal stable around +3.3 v. A 1k or 5k trimmer is utilized with a 240 ohm resistor to make the movable voltage to the required +3.3 v.

3.1.2 Transmitter Circuit

The transmitter circuit has the Spartan3E force, ground and precious stone associations. Notwithstanding the typical associations, two catches are associated with PORTA pins 0 and 1. A draw up resistor of 10k ω is utilized so that the advanced information seen is +5 v or rationale 1. At the point when either catch is squeezed, the information is associated with ground/+0 v making the data a rationale 0. Port B pin 0 is associated with the XBee Commotion pin. This is for the remote information to be yield to the beneficiary.

3.1.3 Receiver Circuit-

The beneficiary circuit has the same standard PIC force, ground and precious stone associations. The contrast between the transmitter is rather than information by means of catches, we are indicating yield with a Drove. So also, the PORTB pin 0 is associated with the Dout pin of the XBee module so that the remotely transmitted data can be produced⁴.

4. Implementation on FPGA

The given inputs and yields of a code are to be interfaced with a FPGA board that we perform an operation. We realize that FPGA goes about as both transmitter and collector. Here we first make a bit document and client imperatives record code where specific inputs and yields are taken by FPGA board and can give a fundamental yield. In the wake of associating FPGA board to our PC or a tablet we scan for the bit record that was made and produce the system.

The Figure 3 represents the block diagram representation of implementation on FPGA with encoder on the transmitter side and decoder on the receiver side. The input sequence given at the transmitter side i.e. at the encoder side must be reflected same at the receiver.

4.1 Implementation Results on FPGA

For the Figure 4, given input sequence “1000” the nexys2 board displays output in the form of led’s.

For the Figure 5, given input sequence “0100” the nexys2 board displays output in the form of led’s.

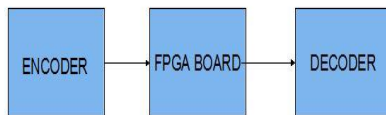

Figure 3. Implementation on FPGA.



Figure 4. For the input sequence 1000.



Figure 5. For the input sequence 0100.

For the Figure 6, given input sequence “0010” the nexys2 board displays output in the form of led’s.

For the Figure 7, given input sequence “0001” the nexys2 board displays output in the form of led’s.

5. Simulation Results

5.1 Output Waveforms

5.1.1 Encoder Results

The Figure 8 shows the encoder results which performs encoding operations of $2^n \times n$.for 2^n operations n outputs will be produced.

5.1.2 Decoder Results

The Figure 9 shows the decoder results which performs encoding operations of $n \times 2^n$.for n operations 2^n outputs will be produced.



Figure 6. For the input sequence 0010.



Figure 7. For the input sequence 0001.

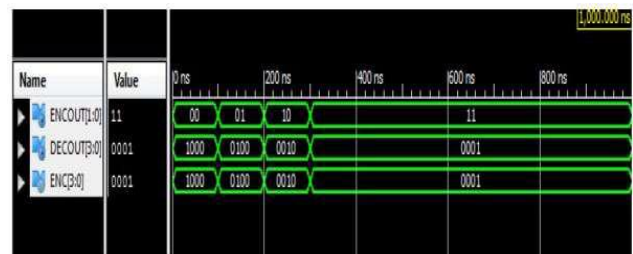

Figure 8. Encoder output waveforms.

5.2 RTL Schematic

The Figure 10 shows the RTL schematic of encoder and decoder operation which will explain about the block diagram

5.3 Technology Schematic

The Figure 11 shows the RTL schematic of encoder and decoder operation which will explain about the block diagram of the top view.

6. Conclusion

This thesis displays the configuration and execution of XBee handset (transceiver) for IEEE 802.15.4. It has been intended to accomplish a complete XBee handset for short range remote correspondence remembering for military application. Every standard supporting short range remote correspondence has distinctive determinations and diverse applications. Nowadays portable correspon-

dence has accomplished wide relevance, yet for utilization of short range correspondence in disengaged region versatile correspondence is extremely hard to actualize. XBee handset gives a flexible innovation to convey in shorter extent.

XBee Handset Outline utilizing FPGA:

- A FPGA outline for XBee handset has been finished in this theory. The advancement was finished through after steps.
- Reproduction of handset execution was completed utilizing Simulink. The craved sign of Simulink model of handset was dissected amid execution examination.
- The baseband handset is depicted in equipment portrayal dialect Verilog HDL

7. Acknowledgement

We sincerely thank to my project guide, who helped me in all aspects of my project to complete in short term. We also thank KL University for providing necessary facilities towards carrying out this work.

8. References

1. XBee Wireless. 2011. Available from: <http://xbewirelessinterface.pyroelectric.com>
2. Mohammed Mian A, Divyabharathi R. Design and simulation of Zigbee transmitter using Verilog. International Conference on Information Communication and Embedded Systems (ICICES); Chennai. 2013 Feb 21-22. p. 882-8.
3. Rafidah A, et al. Verilog-based design and implementation of digital transmitter for Zigbee applications. IJES. 2011 Dec; 1(4):723-34.
4. Abinaya S, Ezhilarasie R, Umamakeswari A. Efficient and secure hierarchical key management scheme for Wireless Sensor Networks using QR decomposition scheme. Indian Journal of Science and Technology. 2015 May; 8(S9):75-81.
5. Harikrishnanand R, Jawahar Senthil Kumar V. An integrated XBee Arduino with group search optimizer approach for localization in Wireless Sensor Networks. Indian Journal of Science and Technology. 2015 Sep; 8(22):1-5.
6. Shamili S, Manivannan D. Sensor node failure detection using multiway tree based round trip path in Wireless Sensor Networks. Indian Journal of Science and Technology. 2015 Jun; 8(12):1-8.
7. Goel S. VHDL based design and implementation of Zigbee transceiver on FPGA. International Journal of Innovative



Figure 9. Decoder output waveforms.

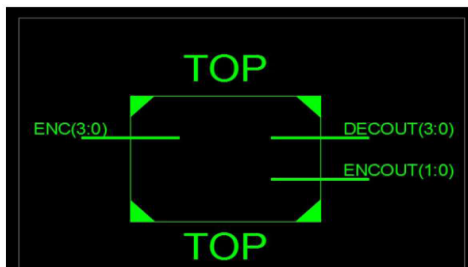

Figure 10. RTL schematic.

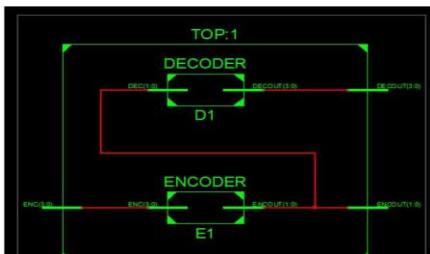

Figure 11. Technology schematic.

- Research in Computer and Communication Engineering. 2013 Apr; 1(2):364–70.
8. Sivakumar R. ZigBee-based wireless electronic scale and its network performance analysis for the application of smart billing system in super markets. *Indian Journal of Science and Technology*. 2014 Mar; 7(3):352–9.
 9. Krithika N. Safety scheme for mining industry using Zigbee Module. *Indian Journal of Science and Technology*. 2014 Aug; 7(8):1222–7.
 10. Sivarajanadevi P. Mobile patient monitoring system for tuberculosis patients using body area networks. *Indian Journal of Science and Technology*. 2015 Jul; 18(58):20–4.
 11. Ramachandra Ramaji P, Asuti MG, Design and implementation of Zigbee transmitter on FPGA using VHDL. *Proceedings of 10th IRF International Conference*; 2014. p. 148–50.
 12. Farahani S. ZigBee coexistence. *ZigBee wireless networks and transceivers*; Burlington, USA: Elsevier; 2008. p. 1–364.
 13. Zigbee Alliance. *Wireless Communications: The Future* William Webb John Wiley and Sons, Ltd. 2007. Available from: www.zigbee.org
 14. *Wireless Medium Access Control (MAC) and Physical Layer (PHY) Specifications for Low-Rate Wireless Personal Area Networks (LR-WPANs)*. IEEE Computer Society; 2006. p. 1–26.