

Examining Fundamental Problems of APC Canal Concrete Lining and Strategies to Solve them

A. Fahmi¹, J. Dabbagh Yarishah¹ and F. Hosseini Mansoub^{2*}

¹Bonab University, Bonab, Iran; Fahmi.ahmad@bonabu.ac.ir, Jamaldabbagh@yahoo.com

²Islamic Azad University, Maragheh Branch, Maragheh, Iran; enhosseini_mec@iau-maragheh.ac.ir

Abstract

Background/Objectives: In this research, various reasons of creation of crack irrigation canals, uplift, and failure of concrete lining, and coping strategies with these problems were investigated. **Methods/Statistical Analysis:** In the main APC canal, the primary type of the canal trapezoid section includes executing a filter at the bottom of the canal, executing soil-cement mixture, and then executing a concrete lining at the walls of the canal. The final type of the canal trapezoid section reformed executing a filter in the bottom and walls of the canal, executing a lean concrete, and then executing the main concrete lining at the bottom and walls of the canal, and also executing a one-sided valve at the bottom of the canal.

Findings: After executing the primary type of the canal section in the first 13 kilometers of the beginning of the APC canal, the phenomenon of crack and uplift have been observed in the concrete lining of the canal wall. However, by changing the properties of canal section and replacing the lean concrete and filter with soil-cement mixture, problems of the concrete lining were noticeably reduced. In this research, reasons of probability of creation of phenomena such as failure, crack, and uplift including executive problems, rising of groundwater level, compaction of the canal body soil, problems due to execution of soil-cement mixture, problems caused by construction joints between panels of the floor and wall of canal, and also other factors were investigated. It is resulted that execution of filter and lean concrete under concrete lining of the canal wall and execution of one-sided valve (Barbakan) has had a noticeable effect on preventing from destructive factors of the concrete lining of canal walls and consequently preventing from creation of crack and uplift phenomena.

Applications/Improvements: By modifying properties of substructure material of the canal lining, problems of concrete lining will be noticeably decreased and each year a large volume of water resources will be saved.

Keywords: Canal, Concrete, Crack, Irrigation Lining, Uplift

1. Introduction

Irrigation canals are primary hydraulic infrastructures from an agricultural point of view, and their performance is highly dependent on the efficiency and durability of their coatings¹. When the operating water surface in the canal is lowered, water must drain away from the canal (through the soil/rock foundation), or back into the canal (through cracks and joints in the canal lining) to lower the phreatic surface in the banks². Construction joints are used at the bottom of the side slopes of concrete lining if the slopes and bottom are placed separately. Longitudinal

joints on side slopes should include one at the line between the cut excavation and the embankment fill, where a crack often appears³.

Since the concrete used in construction of canal linings is usually non-reinforced, it is not able to cope with large bending moments. Hence, risk of rupture of concrete lining under the effect of its own weight, elastoplastic behavior of the subgrade soil and uplift pressure is not unlikely^{4,5}.

APC canal is a canal with 30 kilometers length that after being constructed has a capacity of transferring water as 22 cubic meters per second. Thickness of the concrete

*Author for correspondence

lining is equal to 12.5 cm in a length of 20 kilometers and equal to 10 cm in another length of 10 kilometers which is constructed in site. The most important reason of using concrete as the cover of canals is to decrease the wastes caused by water penetration and increase lifetime of the canals. In this research, various reasons of creation of crack, uplift, and failure of concrete lining, and coping strategies with these problems were investigated.

2. Crack, Failure and Uplift of APC Canal Concrete Lining

Canal linings must be protected against excessive upward movement. For lined canals, protection against hydrostatic uplift must be provided. This is commonly accomplished by under drains or drainage blankets of sand and gravel and/or geosynthetic drainage materials. Where possible, these drains will discharge into adjacent drainage canals or into the structures. For certain lined canals, this may require flap valves on outlets into the canal⁶.

Regarding execution of necessary substructures under the canal concrete lining, it seems that existence of small cracks and uplifts in the canal cover did not cause fundamental problems in operation of the canal. But, any kind of creation of crack, failure, and uplift in the canal cover, even if it is very trivial, because of accumulation of water behind the places of failures and cracks in cold seasons, which cause expansion of these cracks, consequently bring about destruction of the canal concrete lining and besides producing an unpleasant view and water waste of the canal, it decreases lifetime of the canal. Any repair operation of the concrete lining, whether in construction time or operation time of the canal, beside imposing direct expenses to repair and reconstruction, will be followed by indirect expenses caused by downtime of the canal at repair time. Therefore, when executing the canal construction, based on the necessary studies, it is necessary to consider appropriate strategies to cope with canal concrete lining problems.

In the main APC canal, various types of materials were applied for concrete lining and its bed layer in the canal section. The primary type of the canal section includes execution of filter in the bottom of the canal, execution of the soil-cement mixture (Shefteh), and execution of the concrete lining in the canal wall according to Figure 1. After executing the canal, based on properties of the primary canal section type (about 10 kilometers from the beginning of the path) and before starting operation

of the canal, crack, failure, and uplift of concrete lining parts were observed in the parts of the canal which were executed, according to Figure 2. Following creation of such cracks and in order to cope with this phenomenon, by applying some changes in the material of the bed layer and concrete lining, the executive section of the canal was modified and corrected.

The final modified type of the canal section, according to Figure 3, includes execution of filter, lean concrete, and main concrete lining around the canal, together with construction of a one-sided valve (Barbakan) at the canal bottom.

After executing this section, no creation of crack and failure in the canal coverage has been observed so far. However, still some uplifts at the canal wall can be observed in some parts of the canal, but its intensity has been decreased. Of course, the behavior of the canal concrete lining against reasons of creation of cracks and uplifts will be determined after operation of the canal and

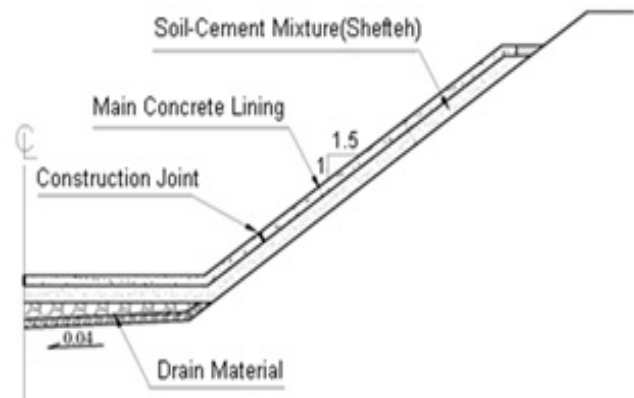

Figure 1. The primary section type of the canal.



Figure 2. Crack, and uplift of concrete lining.

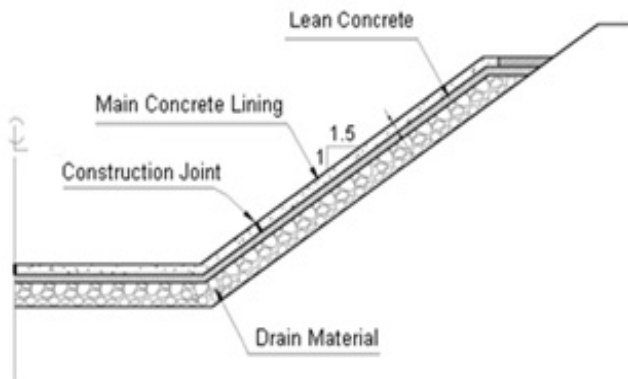

Figure 3. The final modified section type of the canal.

by elapse of time. First, we investigate probable reasons of creation of crack, failure, and uplift in the canal concrete lining. In the following parts, we will investigate strategies of coping with any reason and also the effect of such strategies in the APC canal.

3. Problems Due to Inappropriate Bed of the Canal Concrete Lining

Concrete linings should only be placed on well-consolidated subgrade. Preparation should include filling all voids with suitable material, ensuring adequate compaction of the rest of the foundation by rolling, tamping or vibrating, and trimming the foundation to correct shape^{7,8}.

After completion of the operation of digging the canal (includes digging a box and then making slope of the canal section), the trimming operation is fulfilled in order to prepare construction of the appropriate bed of the canal concrete lining. In most canal construction projects, the trimming operation is conducted by use of excavator machine. The main problem of this method is that the interlock of the embankment layers in the canal coverage bed is touched and before executing concrete lining of the canal lining, it is necessary that the bed would be repaired, stabilized, and become prepared. The best way to stabilize the bed layer is to use lime mortar. By using this material, by penetration of lime in the pores of the bed, firstly, the problem caused by touching the embankment layer is solved, and secondly, an strong bed is prepared for execution of the main concrete of the canal concrete lining.

Of course, in price list of irrigation and drainage, besides using the lime mortar, soil-cement mixture has

also been predicted and is also used in the APC canal primary section for substructure of the concrete lining. In this price list, problems due to execution of cement products, including clay soil materials, have not been considered. The compressive resistance of the samples of soil-cement mixtures executed in the APC canal, is obtained to be 20 (kg/cm²) in the maximum level.

Therefore, it is resulted that not only the soil-cement mixture does not have a noticeable effect on bed stabilization, but regarding resistance aspect, it is not an appropriate material for substructure of the canal concrete lining and causes its especial executive problems. In some parts of the path that intensity of the cracks and failures in the concrete lining is higher and according to Figure 4, the shattered mortar under the coverage is exposed, it can be observed that the soil-cement mixture is very delicate and even can be damaged with hand pressure. Such materials, when executing the canal concrete lining, may absorb the concrete water and become inflated and cause reduction of strength of canal concrete lining.

Fortunately, after modifying and correcting canal concrete material properties, the soil-cement mixture is replaced with the lean concrete. First, the filter material is poured on the repaired surface and after regulating the filter, lean concrete is executed on it. Despite the lean concrete does not have an effective role in stabilization of the soil bed, it can act as a layer between filter and the main concrete and can be used as an appropriate bed layer (with appropriate compressive strength compared to soil-cement mixture) for execution of the canal concrete lining.



Figure 4. Failures in the concrete lining.

4. Problems Due to Increase of Water Level

Increase of groundwater level can be considered from two aspects. Firstly, by increase of the ground water level, the uplift hydraulic pressure exerts to the bottom and walls of the canal. If such pressure won't be depreciated by using effective strategies, it would play an effective role in weakening the canal concrete lining and causes cracks, failures, uplifts. Secondly, in case of existence of potential of swelling in soil material of the canal body, increase of the groundwater level causes that the soil material of the canal body would be inflated by absorbing water and exerts swelling pressures to the canal concrete lining.

According to Figure 1, in the primary section of the canal, the drainage material was only predicted to be executed in the canal bottom and under the soil-cement mixture which had two main problems. Firstly, in rainfall time, according to the regional conditions, the groundwater level increases noticeably. The hydraulic pressure exerted the canal bottom, as a result of increase of the groundwater level, will be accumulated in the canal bottom because of water drainage by use of filter. Hence, because of not predicting an appropriate conduct for exit of the canal bottom water, this pressure will not be depreciated. To cope with this phenomenon, we used one-sided valves (Barbakan) and executed them in the said regions, also in the modified section type of the canal, in order to depreciate the pressure, besides applying Barbakan in the canal bottom, in the whole area of the canal and on the repair surface and under the lean concrete, a layer of filter is executed.

5. Problems Due to Increase of Water Level

Regional conditions of a plain cause operation of canal construction to have various states in order to perform the bottom level of the canal based on the desired codes of height. The canal might be completely below the embankment, or a part of it can be in the embankment and the rest in the natural ground. Swelling potential might exist in the embanked part or in the natural ground. In the embanked part of the APC canal, mixture of the fine aggregate material of the soil loan and material obtained from canal digging operation were used. Considering plasticity property of the dug soil, in spite of mixing the

loan soil with it, to some extents, there is swelling potential in the embankment part of the canal body. However, the part of the canal which is situated in the natural ground, has undergone increase and decrease of groundwater level in the past in the form of alternative cycles and as a result of that its swelling potential has decreased to some level. According to the swelling potential of the soil material of canal body, by increase of the groundwater level and absorption of water by the inflated soil material, a destructive pressure is exerted to the canal concrete lining which may cause creation of cracks, failures, and uplift of the canal lining. In the primary type of the canal executive section, no strategy was predicted to cope with swelling pressure. Of course, by applying Barbakan and draining the water, because of less absorption of water by soil, swelling pressure decreases to some extent. Strategies to cope with such pressures are as follows:

5.1 Execution of Filter Layer around Canal Section

By executing a filter layer around the canal and applying Barbakan in the canal bottom, as a result of drainage, water level in the soil is decreased and consequently swelling pressures are also decreased. Secondly, in case of application of any kind of pressure due to swelling of the filter material because of flexibility, they will depreciate swelling pressures to some extent. By executing such filter around the APC canal, problems caused by crack, failure and uplift will be noticeably decreased.

5.2 Saturation of the Canal Embankment before Execution of Concrete Lining (Flooding the Canal with Water)

Here, the soil material of the canal body which have the potential of swelling are inflated before execution of the concrete lining, and consequently after executing the concrete lining of the canal swelling potential of soil material of canal body decreases noticeably. This method is not used in this project.

5.3 Lack of Application of Soil Mixture Resulted from Canal Digging Operation which have Swelling Potential, in the Canal Body Embankment

Of course, using this method is only applicable in parts of the canal which are completely constructed below the

embankment. In this case, we can completely apply loan material for embankment of the canal body which of course is not economic.

5.4 Decrease of Relative Density of Embankment

Decrease of the relative density value of the embankment layers, noticeably decreases swelling potential of the embankment soil. Application of this strategy can only be useful in some parts of the canal in which the canal is completely situated in the embankment. By decrease of density of embankment layers, in case of existence of swelling pressures, soil body of the canal becomes more flexible and will depreciate forces of the swelling in it, and consequently these pressures won't be exerted to the canal concrete lining.

5.5 Other Methods

Application of water insulation layers, considering lining distances using problematic soils, application of lime mortar in stabilizing the wall under coverage of the canal, and execution of longitudinal drainage along the canal, are of the main strategies to cope with problems of the canal concrete lining.

6. Executive Problems of the Canal Concrete, related to Construction Joints

Since concrete lining of the canal lining is not armed, applying vibration operation when pouring the concrete, because of thin layer of the concrete, is considered as an executive problem. Hence, execution of concrete in the canal walls is faced with problems which may be effective in uplifts of the canal wall. One of the factors

which causes the weakness of concrete in the bottom of the slope, is separation of the concrete aggregates from each other which occurs due to movement of the concrete on the slope which causes that fine aggregates of the concrete material to be accumulated and focused in the bottom of the canal. Now, for smoothing the concrete surface, if smoothing operation is fulfilled from top side to the bottom side of the slope, this separation of fine aggregates will be intensified. Also, it is difficult, time-consuming, and expensive to smooth the concrete surface from down side to the top side of the slope manually, so it is not applicable. Hence, to decrease the phenomenon of separation of fine aggregates in the toe of slope of the concrete canal, a construction joint in the height 30 cm to 50 cm from the bottom level is executed and by the end of the concrete pouring operation for the mentioned panel, insulation operation of this joint is performed using two layer of bitumen, and after a while, panel of the wall is executed. Therefore, canal section is executed in four parts (two bottom and two wall panels) according to Figure 5. Of course, in some parts of the bottom that the width of the canal bottom is decreased, concrete pouring operation includes three parts of concrete pouring (a bottom panel and two wall panels).

Considering the reliance of the canal concrete lining and fulfillment of its substructure on non-homogenous soil material, existence of construction joints especially in walls cause that the canal concrete lining, according to Figures 5, 6 won't be resistant against uniform pressures and result in uplift of the canal lining wall panels.

By executing contraction joints instead of construction joints between bottom and wall panels, it is expected that uplift of panels would be removed and the probable cracks created due to exerted pressures to the contraction joint would be depreciated. Of course, in the primary section of the canal, because of weak substructure of the concrete lining, weakness due to lack of coherence of the

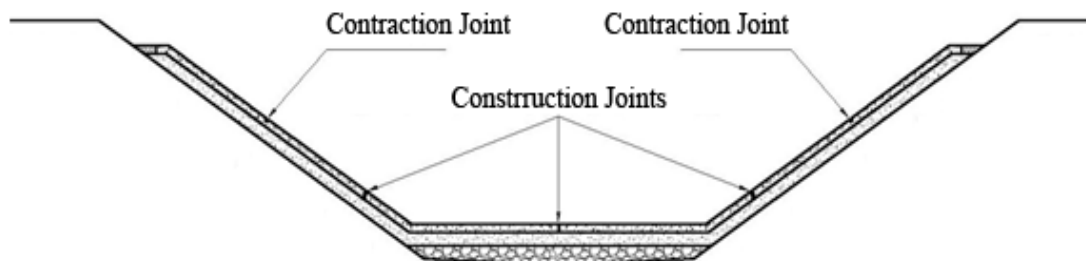

Figure 5. Contraction and construction joints.

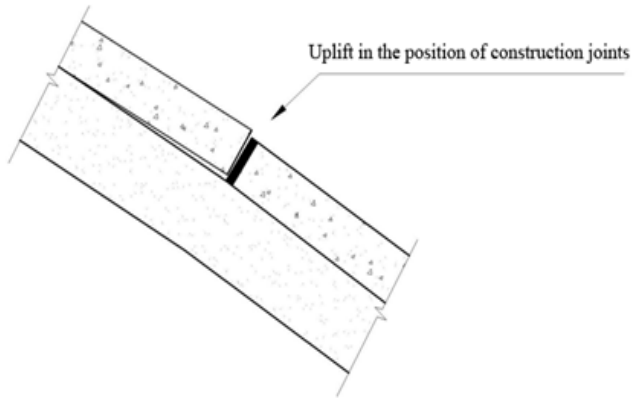

Figure 6. Detail of uplift in the position of construction joints.

concrete lining is noticeable, but in the modified section of the canal, because of existence of a stronger substructure under the concrete lining, and also executing filter, this problem is of a less importance.

6.1 Investigating Strategies to Cope with Creation of Crack, Failure, and Uplift of the APC Canal Concrete Lining

By modifying properties of the consuming material for substructure of the APC canal concrete lining and using filter and lean concrete under the concrete lining, problems such as crack and failure have not been observed so far and only some small uplifts were observed in some parts of the canal with modified section. Of course, by elapse of time and especially after exploitation of the canal, such phenomena may appear again. However, by comparing the two sections executed for the canal, it can be concluded that by applying filter material and lean concrete for substructure of concrete lining, problems such as crack and failure will be decreased to a large extent. In other words, weak concrete lining with soil-cement mixture, which itself is an intensifying factor of crack propagation was removed and instead of that, a stronger substructure (lean concrete) was executed. In addition to this measure, the filter executed under the lean concrete was also effective in depreciation of such stresses. However, uplift problem of the concrete lining, even in a very limited value can be serious. Therefore, we should be looking for more effective strategies to cope with uplift of canal wall panels. Since hydraulic pressure due to increase of groundwater level and swelling pressure is noticeable, we should be looking for an strategy for more

depreciation of these forces. Of the proposed strategies, the following items can be mentioned.

6.1.1 Execution of Longitudinal Drain along the Canal

Placement of a drainage layer with appropriate thickness can reduce the swelling hazards but increasing the drainage layer beneath the Canal base should be limited because using thick drainage layer may reduce the basement stiffness which causes the Canal basement subjected to large settlements⁹.

By executing a drain, either in the form of open-head or drain constructed by filter materials, all problems due to increase of groundwater level, surface runoffs due to rainfall and waters resulted from irrigation of adjacent lands of the canal can be solved. In this process, by draining the waters, problems of swelling pressure due to absorption of water by soil will be solved. By executing such drains, execution of filters in the walls of the canals won't be necessary, but executive expenses and also expenses for buying vaster lands for executing such drains would increase the project cost. Of course, direct and indirect expense of repairing the canal concrete lining after exploitation of the canal would be much higher.

6.1.2 Execution of a Resistant Separating Layer between Canal Embankment and Canal Concrete Lining

One of the most appropriate methods to prevent from concrete failure is to execute a resistant separating layer between the canal embankment and canal concrete lining together with executing a lime mortar in the last embankment layers of the canal body.

6.1.3 Executing Deep Water Layers of Geo-Membrane under Concrete Lining

Executing water insulation layers such as geo-membrane under concrete lining noticeably prevents penetration of water in the embankment and also prevents change of water conditions. Therefore, problems due to swelling of canal soil material noticeably decrease.

The geo-membrane provides the water barrier, while the concrete cover protects the geo-membrane from mechanical damage and weathering. The system effectiveness is estimated at 95 percent. The irrigation district can readily maintain the concrete cover, but does not have to maintain the geo-membrane under-liner¹⁰.

7. Conclusion

In APC canal project, by modifying properties of sub-structure material of the canal concrete lining from soil-cement mixture to filter and lean concrete, problems of concrete lining such as creation of cracks and failures would be noticeably decreased, meaning that the mentioned strategies are effective.

8. References

1. Morgado F, Lopes G, de Brito J, Feiteira J. Portuguese irrigation canals: Lining solutions anomalies, and rehabilitation. *Journal of Performance of Constructed Facilities*. 2012; 26(4):507–15.
2. Bureau of Reclamation. Canal Lining Drawdown Tests and Development of New Drawdown Criteria for the Charles Hansen Feeder Canal. Denver, Colorado: U.S. Department of the Interior, Technical Service Center, Hydraulic Investigations and Laboratory Services Group; 2012. p. 2.
3. Joints in Concrete Construction. Farmington Hills, MI: American Concrete Institute (ACI); 1995. p. 3.
4. Kassiff G, Eting A, Zeitlen JG. Failure mechanism of canal lining in expansive clay. *Journal of the Soil Mechanics and Foundations Division*. 1967; 93 (1):95–120.
5. Ahmadi et al. Optimizing the location of contraction-expansion joints in concrete canal lining. *Journal of Irrigation and Drainage*. 2009; 58(1):116–25.
6. United States Bureau of Reclamation USBR. *Earth Manual*. Third Ed Part 1. Colorado, USA; 1998, p. 230.
7. Australian National Committee of Irrigation and Drainage. *Open Canal Seepage and Control Guidelines for Canal Seepage Remediation*. 2004. p. 92.
8. Stevenson BA. *Repair and Replacement Options for Concrete Lined Irrigation Canals*, Land and Water Resources Research and Development Corporation, Department of Natural Resources. Queensland; 1999.
9. Jafarzadeh F, Akbari Garakani A. Retrofitting methods to improve the swelling potential in water conveying canals (a case study), 2012. 4th International Conference on Problematic Soils; 2012; Wuhan, China. p. 1-6.
10. Bureau of Reclamation. *Canal Lining Demonstration Project, 10-Year Final Report*. 2002.