

Soft-Switching Bidirectional Buck Boost Converter with Simple Auxiliary Circuit

J. Barsana Banu* and M. Balasingh Moses

Department of Electrical and Electronics Engineering, Anna University, Trichirapalli - 620024, Tamil Nadu, India;
barsana.thameem@gmail.com, m.balasinghmoses@aubit.edu.in

Abstract

Objectives: The intention of this paper is to project a soft switching bidirectional buck boost converter with high efficiency, simple structure for the application of battery charging and discharging. **Methods/Statistical Analysis:** MATLAB/SIMULINK software has been used to obtain the simulation results and thereby efficiency of the projected configuration is evaluated and examine with the traditional transformer less bi-directional converters. **Findings:** The proposed converter introduces a simple auxiliary circuit that not only reduces the switching stress but also provides high efficiency to the converter. This non isolated soft switching bidirectional buck-boost converter operation is based on two categories namely Boost and Buck mode as same that of other bidirectional converter (BDC) topologies but with simple characteristics. The proposed converter with auxiliary/snubber achieves soft switching at all step-up and step-down modes. The various operational modes of the proposed method have been investigated throughout the paper. **Application/Improvements:** The proposed system is suitable for battery charging and discharging systems.

Keywords: Auxiliary Circuit, Battery Charging and Discharging, Bidirectional Buck-Boost Converter, Efficiency, Soft Switching

1. Introduction

Recently, bidirectional buck-boost converter has the significant investigate area owing to the growing demand of bidirectional shifting of energy among two sources, which are widely used in uninterrupted power supply, electric vehicles, battery charges and fuel cells. In most of the battery charges, bidirectional dc-dc converters are classified into two categories isolated and non- isolated depending on the requirements. One such isolated bidirectional dc-dc converter consists of two bridges that are isolated by a high-frequency isolation transformer are usually employed¹⁻³. Dual active bridge isolated bidirectional are proposed to raise the power level^{4,5}. The major focus on voltage spike reduction, reducing voltage and current stresses through the active switches, and soft switching is

achieved by employing isolated bidirectional dc-dc converter with some snubber RCD, fly back, active clamp and passive clamp methods are described to improve the conversion ratio⁶⁻⁸. Auxiliary circuits are sometimes used to achieve ZVS in the bidirectional converter⁹.

Due to volume, weight, high number of semiconductor devices and losses in the snubber circuit and power transformer used in isolated converter, the interest is focused to the transformer less non-isolated bidirectional DC-DC converter(NBDC)¹⁰ they are reduced more number of switches to reduce losses. To diminish the ripple current appeared in the conventional NBDC multiphase interleaved half bridge topology is introduced¹¹. Due to the low ripple current and reverse recovery problem in the conventional NBDC, resonance strategies such as series, parallel and quasi-resonance has progressed to

*Author for correspondence

lighten the above issue^{12,13}. Owing to high-power conduction misfortunes are happened in the resonant converter topologies, the Zero Voltage Transition (ZVT) and Zero Current Transition (ZCT) strategies are acquainted with conquer the issues in the resonant converter¹⁴.

The ZVT and ZCT methodologies are that the primary switches are made to ON and OFF at voltage and current to be zero utilizing resonance condition. Once in a while auxiliary switches are utilized as a part of expansion with primary switches to work the NBDC without switching misfortunes¹⁵ Zero Voltage transition PWM NBDC is actualized with coupled inductor to accomplish high efficiency at both step up and step down conversion¹⁶. Leakage inductance is fully utilized and voltage stress in the switches reduced by providing tapped inductor topology¹⁷.

Coupled inductor based Modified PWM non isolated bidirectional converter is introduced to diminish the converter volume¹⁸. Further soft switching NBDC with LC Series resonant circuit is likewise introduced to accomplish high efficiency at every load conditions¹⁹. Soft-switching dc-dc converter added with two additional switches is introduced to enhance the efficiency of the traditional transformer less bi-directional converter by lookup chart reference²⁰. This technique leads the high proficient operation during step-up and step-down modes.

In this article soft switching bidirectional buck boost converter with simple auxiliary circuit is presented. The proposed technique accomplishes maximum efficiency with soft switching at both step-up and step-down transformation. The benefits of the projected configuration are high consistency, easy arrangement, minimum cost and maximum efficiency.

2. Proposed Converter Configuration and Operation

The proposed soft switching bidirectional buck boost converter with simple auxiliary circuit is represented in Figure.1. The proposed auxiliary circuit comprises of auxiliary Capacitor C_s , auxiliary resistance R_s and auxiliary diode D_s is added with essential buck boost converter techniques. The auxiliary resistance R_s always dissipates power and diode in the RCD snubber have a low forward voltage transient and finite reverse recovery time, which allows the opposite direction flow of iL_m .

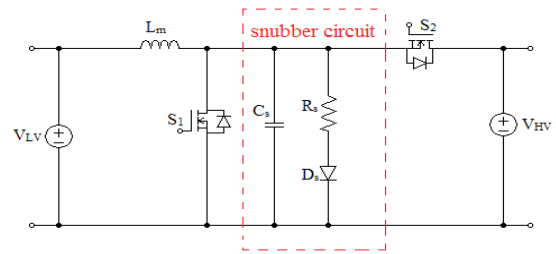

Figure 1. Soft switching bidirectional buck boost converter with simple auxiliary circuit.

Figure.1 comprises of Principle inductor L_m , two primary switches S_1 and S_2 are worked under soft switching, principle inductor L_m accomplish output filtering as power exchanged from the low-voltage input to the batteries (high voltage side), which is indicated as a boost mode and the other way around operation happens in buck mode when power moves from the batteries (high-voltage output side) to the input low-voltage side. The resonance of the projected method is realized by the primary inductor and auxiliary capacitor. The simple auxiliary circuit works by absorbing the current in the main inductor once the switch voltage exceeds the auxiliary capacitor voltage and the ZVS situation could be accomplished at the instant; the current of auxiliary resistance is superior to that of principle inductance.

A soft switching bidirectional buck boost converter with simple auxiliary circuit have two sorts of transformations step up transformation (boost mode) and step down transformation (buck mode) based upon the current moving through every element in the projected configuration and voltage over the primary switches.

In step up transformation switch S_1 controlled and intrinsic diodes of S_2 provide a current path to the load. In step down transformation switch S_2 controlled and parasitic diodes of S_1 provide a current path to the load. To simplify the steady-state analysis of the proposed converter following assumptions is made as follows.

1. Snubber capacitor C_s is expected sufficiently extensive to be considered.
2. All the semiconductor devices have zero voltage drops.
3. All the switches and passive components are thought to be ideal

2.1 Boost Mode (Step Up transformation)

In boost mode switch, S_1 is operated intrinsic diode of the switch S_2 will conduct to transfer power from the primary

low-voltage side to the secondary high-voltage side. In this stage, auxiliary capacitor C_s makes the switch S_1 to turn OFF by ZVS. The operation mode of proposed technique in boost mode is distinct into five modes. Figure. 2 demonstrate the operation mode of step-up transformation. Figure.3 demonstrates the typical converter waveforms of the projected converter in step up transformation through switching transitions.

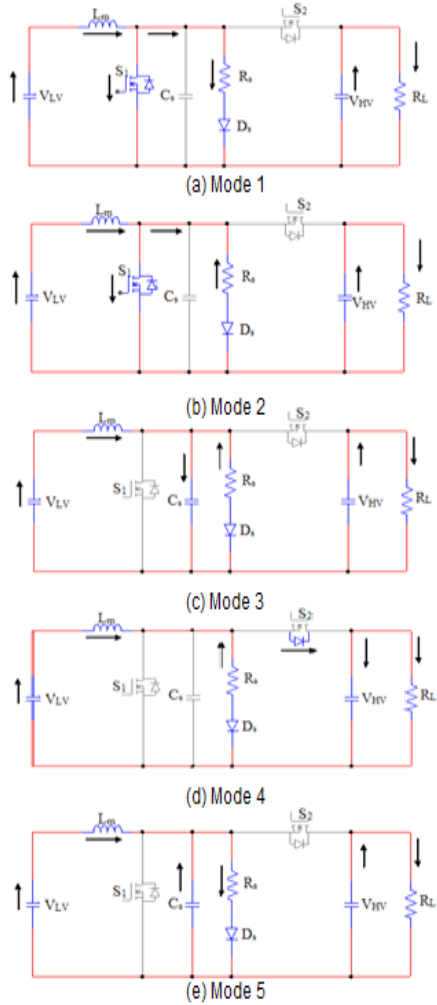

Figure 2. Operation modes of boost mode transformation (a) Mode 1, (b) Mode 2, (c) Mode 3, (d) Mode 4, (e) Mode 5.

Mode 1 [$t_0 \leq t < t_1$]: Mode 1 begins when the primary switch S_1 is turned ON. The primary inductor current iL_m streams to switch S_1 and auxiliary circuit. At this interval, the auxiliary resistor current iR_s decreased to zero and the auxiliary capacitor C_s is fully charged.

Mode 2 [$t_1 \leq t < t_2$]: At time t_1 , the direction of iR_s is changed. i_L and iR_s are extra together and the follow-on current flows to the switch S_1

Mode 3 [$t_2 \leq t < t_3$]: This stage is ongoing when the switch S_1 is turned OFF with ZVS condition and current flows to auxiliary capacitor C_s . Switch S_1 is zero voltage situation. The voltage of auxiliary capacitor reaches to output voltage V_o (V_{hv})

Mode 4 [$t_3 \leq t < t_4$]: This interval starts at t_3 , the voltage across C_s is equivalent to V_{hv} and parasitic diode of S_2 begins conducts. The exciting energy of the primary inductor L_m and the auxiliary circuit is shifted to the resistive load via the parasitic diode of S_2 . This interval stops at t_4 when C_s is completely discharged and the path of iR_s is changed.

Mode 5 [$t_4 \leq t < t_5$]: At time t_4 , mode 5 initiates as the direction of iR_s returns to initial position. The voltage across C_s starts to discharge. Then the output voltage V_o is greater than C_s , finally anti parallel diode of the switch S_2 turns OFF.

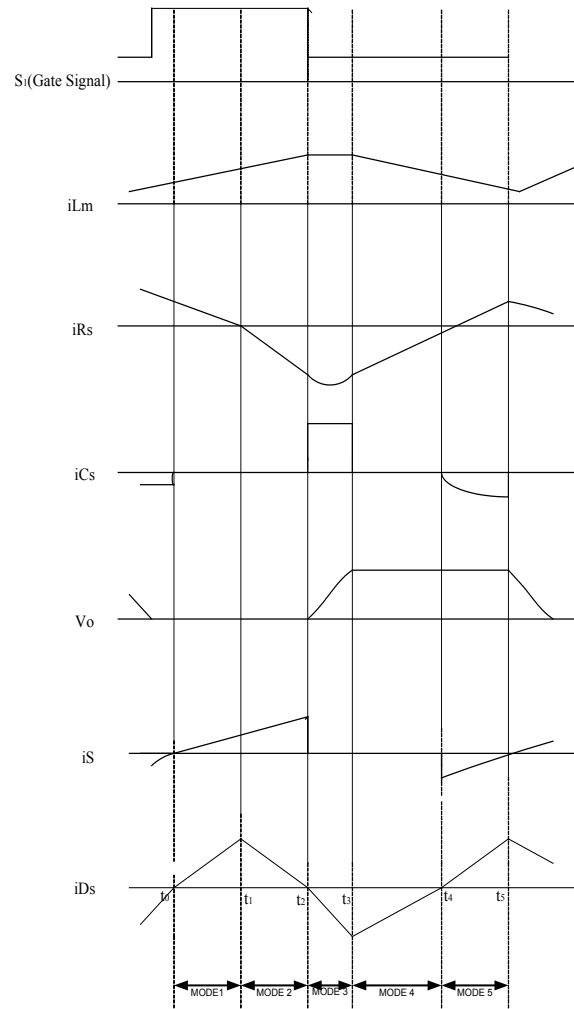

Figure 3. Typical converter waveforms boost mode transformation.

2.2 Buck Mode (Step-Down transformation)

In buck mode switch, S_2 is controlled body diode of the switch S_1 will operated to transfer power from high-voltage side to low-voltage side. In this mode, auxiliary capacitor C_s makes the switch S_2 to turn OFF by ZVS. The operation mode of proposed technique in buck mode is sort into five modes. Figure. 4 demonstrate the operation mode of step-down transformation. Figure.5 demonstrates the typical converter waveforms of the projected converter in step down transformation through switching transitions.

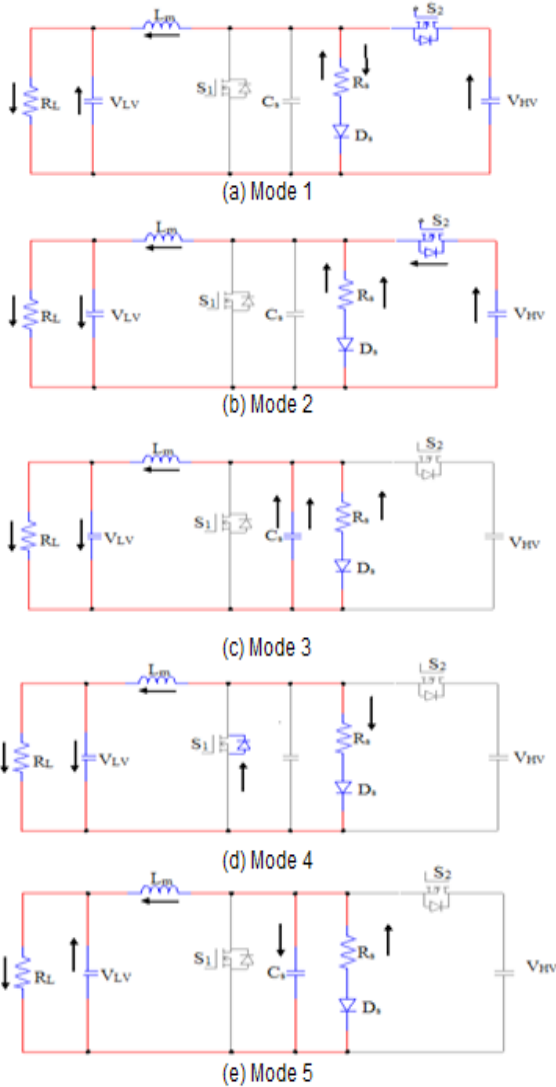

Figure 4. Operation modes of buck mode transformation (a)Mode 1, (b) Mode 2, (c)Mode 3, (d) Mode 4, (e)Mode 5.

Mode 1 [$t_0 \leq t < t_1$]: Mode 1 begins when the primary switch S_2 turns ON. The current through the high-voltage side iL_{hv} flows to primary switch S_2 and auxiliary circuit. Throughout this interval, the auxiliary resistor current iR_s decreased to zero and then auxiliary diode D_s conducts.

Mode 2 [$t_1 \leq t < t_2$]: At time t_1 , the direction of iR_s is changed iL_{hv} and iR_s are added together and the resulting current flows to the switch S_2

Mode 3 [$t_2 \leq t < t_3$]: This interval begins at the switch S_2 is turned OFF with ZVS situation and current streams to auxiliary capacitor C_s . Primary switch S_2 attains the voltage state by zero. The voltage of an auxiliary capacitor starts rises.

Mode 4 [$t_3 \leq t < t_4$]: This interval starts at t_3 , the voltage across C_s is equivalent to $V_o(V_{lv})$ and intrinsic diode of S_1 begins conducting. The charged energy of the auxiliary circuit is shifted to the resistive load via the intrinsic diode of S_2 . This stage stops at t_4 when C_s is entirely discharged and the direction of iR_s is changed.

Mode 5 [$t_4 \leq t < t_5$]: At time t_4 , mode 5 initiates as the direction of iR_s returns to initial position. The voltage across C_s starts to discharge. Then the output voltage V_o is greater than C_s . Finally anti parallel diode of the switch S_1 turns OFF.

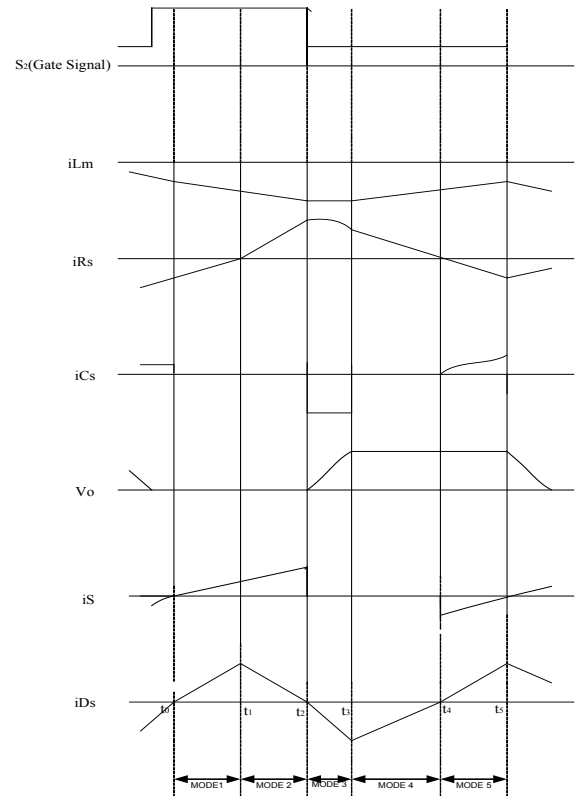

Figure 5. Typical converter waveforms buck mode transformation.

3. Converter Design Considerations

To design the converter, theoretical analysis should be determined. The major objective of the steady-state analysis is to attain derivative equations for different components utilized in the proposed arrangement.

3.1 Design of Primary Inductor

The current fed inductors participate in a chief role in energy exchange between LV to HV side and vice versa as well as in the implementation of soft switching. Their qualities ought to be resolved scientifically.

$$L_m \leq \frac{DR_L(1-D)^2}{2f_s} \quad (1)$$

3.2 Design of Auxiliary Resistance

A large value of auxiliary resistance will reduce the discharge time of the auxiliary capacitor and allow the voltage to rise to be a higher value. A smaller value of R_s will result in a low clamp voltage, but the dissipation will be increased.

$$R_s \leq \frac{1}{2.3f_s C_s} \quad (2)$$

3.3 Design of Auxiliary Capacitor

The value of the auxiliary capacitor assumed to be the high value to maintain a constant voltage when the main inductor energy absorbed.

$$C_s = \frac{L_m i_L^2}{(V_{cp} - V_{LV})^2} \quad (3)$$

The energy stored in the main inductor moves to an auxiliary capacitor which absorbs energy without the rise in voltage.

3.4 Auxiliary Diode

Auxiliary diode is selected that has to allow transient forward voltage, short reverse recovery time and soft recovery.

3.5 Power Dissipation

The power dissipation caused by resistance and capacitance of the auxiliary circuit is given by.

$$P_R = \frac{Li_0^2 f_s}{2} \quad (4)$$

$$P_c = \frac{C_s V_{Lv}^2 f_s}{2} \quad (5)$$

3.6 Output Voltage

The output voltage of a boost converter is obtained from.

$$C_0 = \frac{DV_0}{\Delta V c R f_s} \quad (6)$$

4. Simulation Results and Discussions

The proposed soft switching bidirectional buck boost converter with auxiliary circuit is simulated using MATLAB/SIMULINK package to validate its effectiveness for both step-up and step-down modes. The results obtained from simulation of the projected topology are compared with the traditional results of NBDC.

4.1 Step-Up Conversion (Boost Mode)

Figure.6 shows the Simulink model for boost mode. In Figure.7, the simulation results for a constant dc input voltage of 100 V is obtained. The output dc voltage of the boost mode (240 V) is the high conversion ratio than the given input voltage in the proposed converter when compared to the other traditional circuits appeared in Figure.8. The input and output power also described in Figure.9.

Figure.10 describes the simulated waveforms of gate pulse, current moving through and voltage across the switch S_1 . From the figure, it is observed that gate signal

is given only for S_1 varies the triggering for the switch S_2 is zero. Also it is observed that the switch S_1 is operated under soft switching techniques.

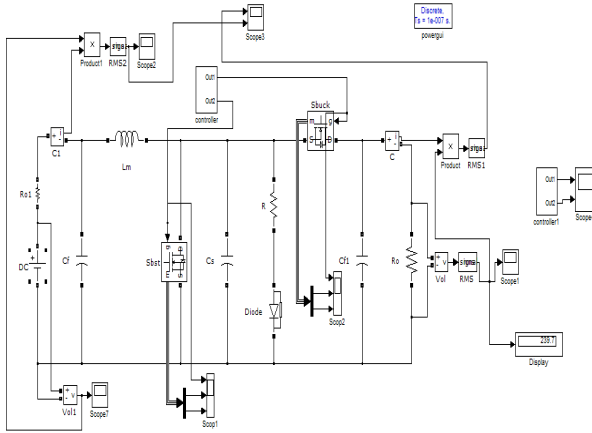

Figure 6. Simulink model for boost mode.

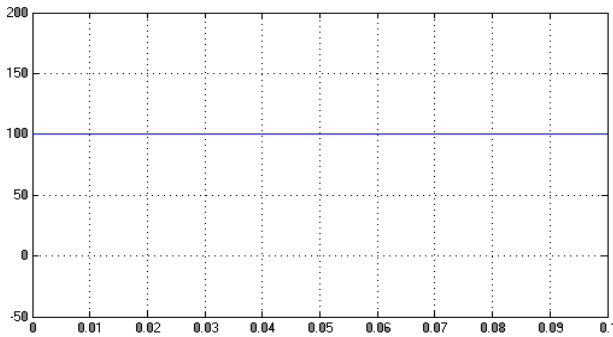

Figure 7. Input voltage for boost mode.

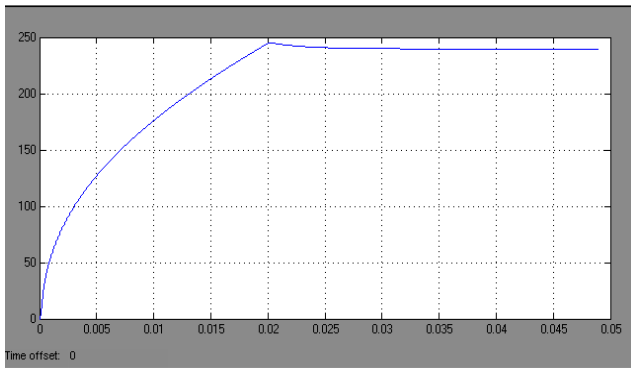

Figure 8. Simulated output voltage for boost mode.

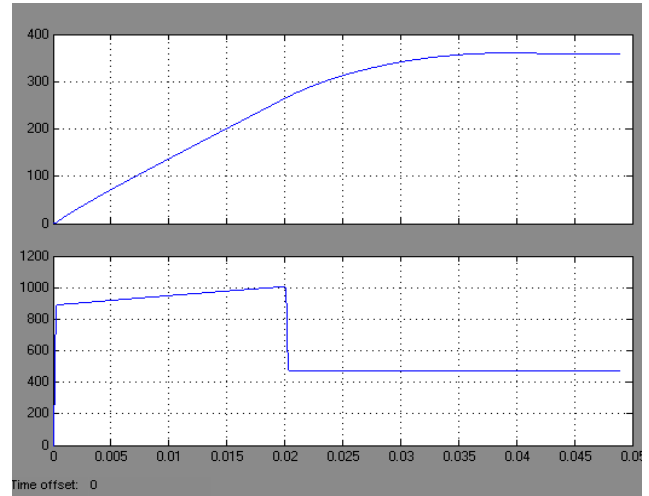

Figure 9. Input power and output power for boost mode.

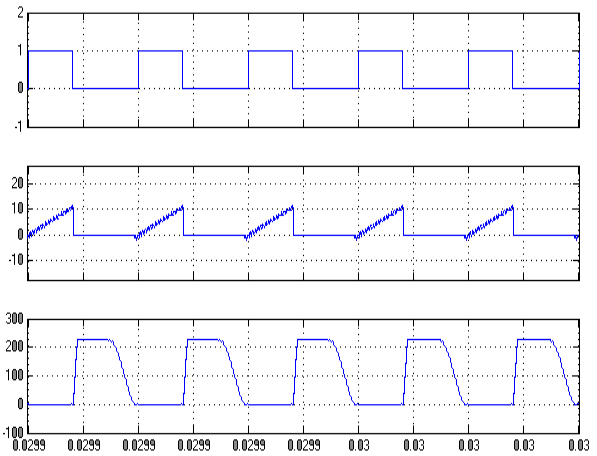

Figure 10. Gate pulse, current and voltage across S_1 .

4.2 Step-down Conversion (Buck Mode)

Figure.11 shows the simulink model for buck mode. In Figure 12, the simulation results for a constant dc input voltage of 240 V is obtained. The output dc voltage is stepped down to 100 V as described in Figure 13. The simulated input power and output power is indicated in Figure.14.

Figure.15 illustrated the simulated waveforms of gate pulse, current flow through and voltage over the switch S_2 . From the figure, it is obvious that switching pulse is given only for S_2 but the triggering for the switch S_1 is zero. Moreover, it is inferred that the primary switch S_2 is also operated under ZVS method.

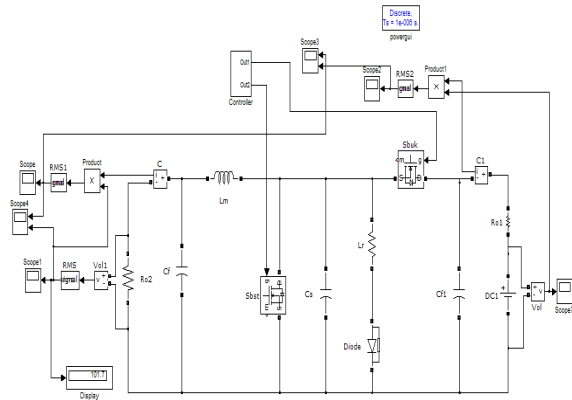

Figure 11. Simulink model for buck mode.

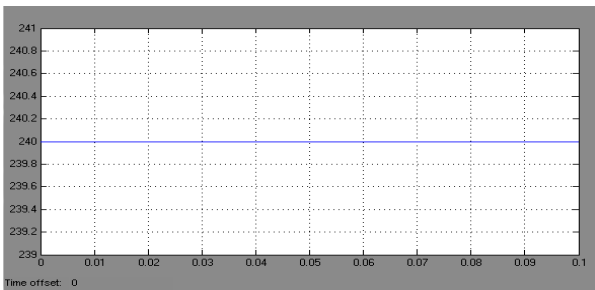

Figure 12. Input voltage for buck mode.

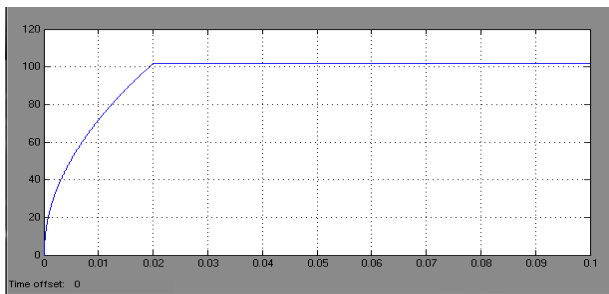

Figure 13. Simulated output voltage for buck mode.

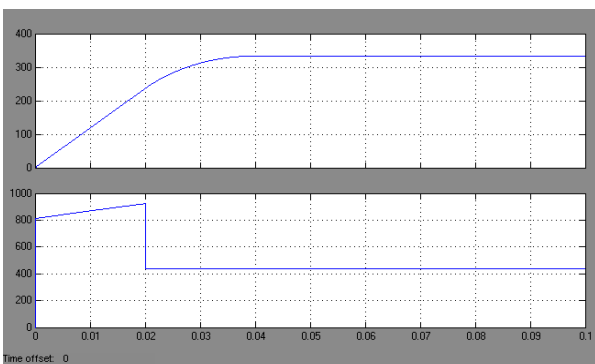

Figure 14. Input power and output power for buck mode.

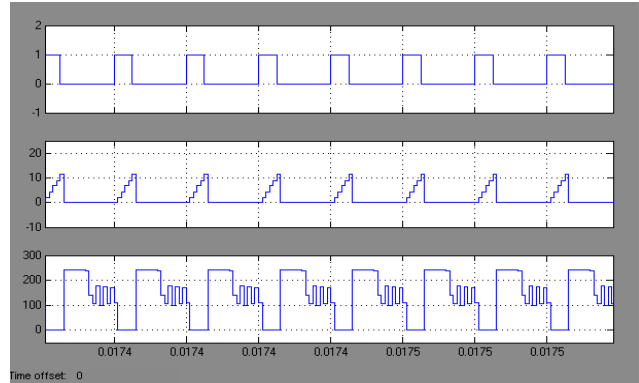

Figure 15. Gate pulse, current and voltage across S_2 .

5. Comparative Result Analysis

In battery charging and discharging applications, reliability and efficiency are important criteria for bidirectional converter design. This section presents a comparative analysis of the topology for the different NBDC. Their efficiency, output power and output voltage evaluations are carried out.

For comparison three topologies, non isolated bidirectional dc-dc converter with auxiliary circuit, LC resonant circuit and proposed simple auxiliary circuits are illustrated and confirmed.

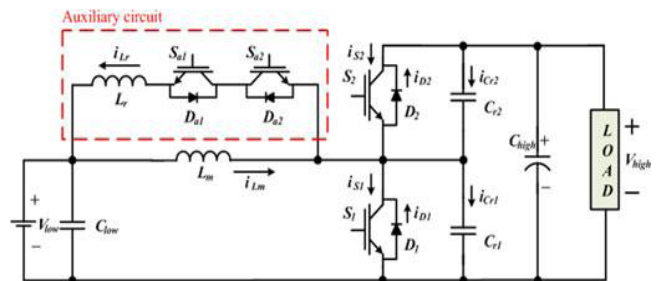

Figure 16. Non isolated bidirectional dc-dc converter with auxiliary circuit.

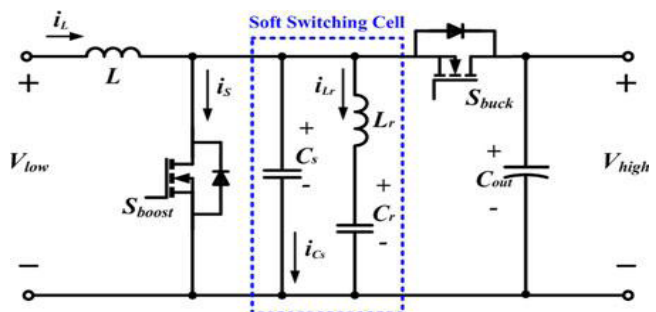

Figure 17. Non isolated bidirectional dc-dc converter with LC circuit.

Non isolated bidirectional dc-dc converter with auxiliary circuit is appeared in Figure 16 and Figure 17 demonstrates the circuit diagram of the non isolated bidirectional dc-dc converter with LC resonant circuit. These two NBDC results are compared with the proposed NBDC with simple passive auxiliary circuit to check the attainability of the converter.

Figure 18 demonstrates the comparison of output voltage versus input voltage of the projected converter with other two conventional NBDC converters and it is observed that proposed circuit produces the high voltage comparatively other conventional converters. Figure 19 and Figure 20 describe the output power and efficiency comparative plots for boost mode conversion

Figure 21, Figure 22 and Figure 23 illustrated the comparative plots of input voltage versus output voltage, output power and efficiency for buck mode transformation.

5.1 Boost Mode

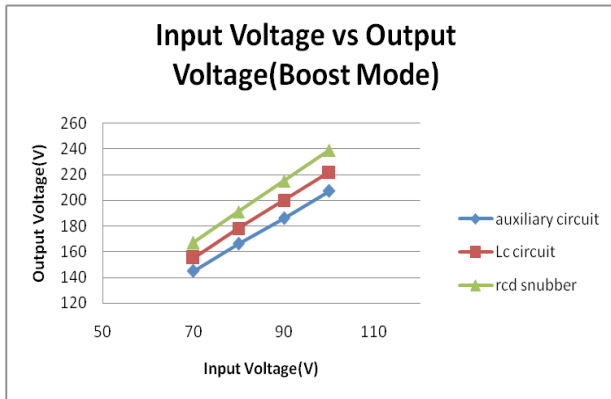

Figure 18. Output voltage comparison of three NBDC boost converter with the changing of input voltage.

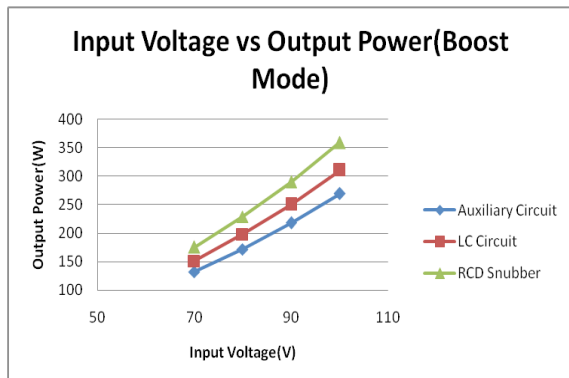

Figure 19. Output Power comparison of three NBDC boost converter with the changing of input voltage.

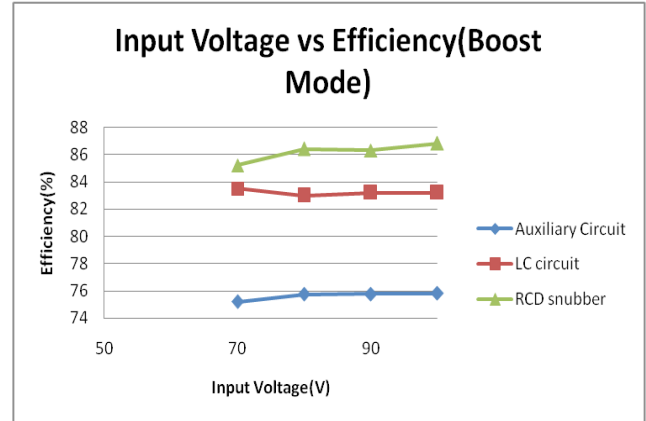

Figure 20. Efficiency comparison of three NBDC boost converter with the changing of input voltage.

5.2 Buck mode

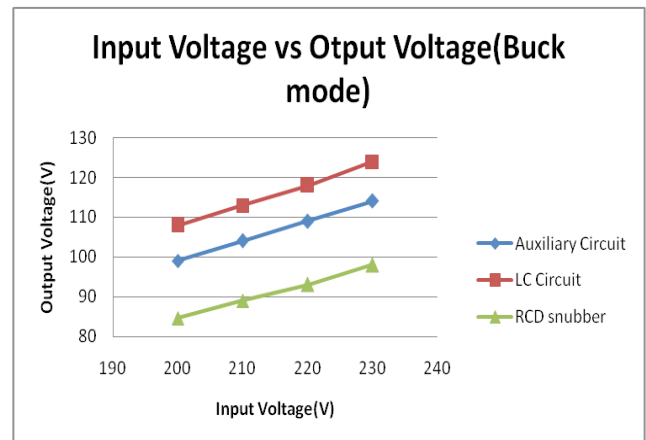

Figure 21. Output voltage comparison of three NBDC buck converter with the changing of input voltage.

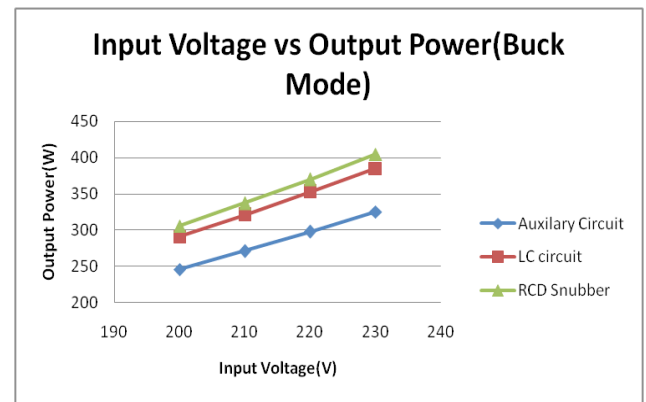

Figure 22. Output power comparison of three NBDC buck converter with the changing of input voltage.

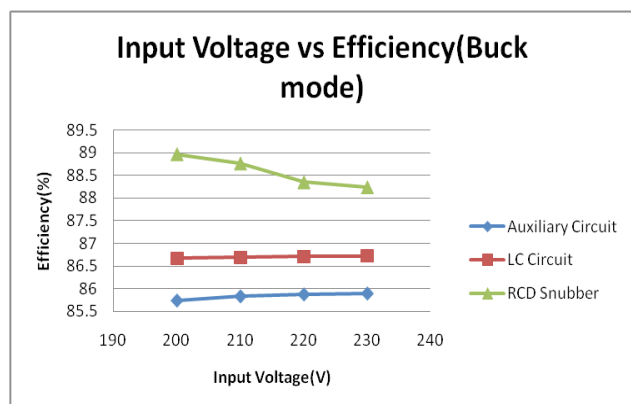

Figure 23. Efficiency comparison of three NBDC buck converter with the changing of input voltage.

For all conditions investigated soft switching bidirectional buck boost converter with auxiliary circuit provides high-output voltage and output power as well as achieves high efficiency than the conventional converters.

6. Conclusions

In this article, soft switching bidirectional buck-boost converter with a simple auxiliary circuit for the battery applications is proposed. The proposed topology is analyzed using the circuit analysis method of operating mode. The primary switches are operated under zero-voltage condition by adding RCD clamp in addition to the essential bidirectional buck boost converter. The proposed topology achieves high efficiency by reducing high-voltage spike and the output voltage oscillations in the diode reverse recovery time. The proposed converter operation is based upon the current moving through every element in the projected configuration and voltage over the primary switches. The proposed topology is simulated using MATLAB/SIMULINK package, and these outcomes are confirmed with traditional bidirectional buck boost converter for its feasibility. Mode examination, design contemplations and simulated results are demonstrated to check the validity of the proposed technique.

7. References

- Zhu L. A novel soft-commutating isolated boost full-bridge zvs-pwm dc-dc converter for bidirectional high power applications. *IEEE Transactions of Power Electronics*. 2006; 21(2):422–9.
- Inoue S, Akagi H. A bidirectional dc-dc converter for an energy storage system with galvanic isolation. *IEEE Transactions of Power Electronics*. 2007; 22(6): 2299–306.
- Reimann T, Szeponik S, Berger G. A novel control principle of bi-directional dc-dc power conversion. In *Proceeding of Power Electronics Special Conference, USA*. 1997. p. 978–84.
- Doncker DRW, Divan DM, Kheraluwala MH. Power conversion apparatus for dc-dc conversion using dual active bridges. 2007; OS. Patent No. 5, 027,261.
- Santhoshi KB, Sundaram MK, Sivasubramanian M, Akila S. A novel multiport bidirectional dual active bridge dc-dc converter for renewable power generation systems. *Indian Journal of Science and Technology*. 2016; 9(1):1–4.
- Moses BM, Banu BJ. A new isolated bidirectional full bridge buck-boost converter with LCD clamp circuit. *IEEE Conference on Energy Conversion (CENCON), Johor bahru, Malaysia*. 2015. p. 25–30.
- Watson R, Lee FC. A soft-switched full-bridge boost converter employing an active-clamp circuit. In *Proceeding of Power Electronics Special Conference, USA*. 1996. p. 1948–54.
- Wu TF, Yang JG, Kuo CL, Sun KH, Chen YK. Comparison of bi-directional isolated full-bridge converters with combinations of active and passive snubbers. In *Proceedings IEEE Power Electronics Special Conference, USA*. 2011. p. 127–33.
- Baei M. A new zvs-pwm full-bridge boost converter. *Journal of Power Electronics*. 2014; 14(2): 237–48.
- Usha S, Subramani C, Naidu DB, Venkatesh VMSR. Analysis of non-isolated bidirectional active clamped dc-dc converter for pv and battery integrated systems. *Indian Journal of Science and Technology*. 2016; 9(22):1–7.
- Kang T, Kim C, Suh Y. A design and control of bidirectional non isolated dc-dc converter for rapid electric vehicle charging system. *27th annual IEEE Applied Power Electronics Conference and Exposition (APEC), India*. 2012. p. 14–21.
- Redl R, Molnar B, Sokal NO. Class E resonant regulated dc/dc power converters: Analysis of operation and experimental results at 1.5 MHz. *IEEE Transactions of Power Electronics*. 1986; 1(2):111–20.
- Liu KH, Oruganti R, Lee FC. Quasi-resonant converters topologies and characteristics. *IEEE Transactions of Power Electronics*. 1987; 2(1):62–71.
- Hua G, Leu C, Jiang Y, Lee FC. Novel zero-voltage transition pwm converters. *IEEE Transactions of Power Electronics*. 1994; 9(2):213–9.
- Lee DY, Kee MK, Hyun DS, Choy I. New zero-current-transition PWM DC/DC converters without current stress.

- IEEE Transactions of Power Electronics. 2003; 18(1): 95–104.
16. Mirzaei A, Jusoh A, Salam Z. Design and implementation of high efficiency non-isolated bidirectional zero voltage transition pulse with modulated DC-DC converters. Elsevier Energy. 2012; 47(1):358–69.
 17. Kang J, Han SK, Han J. Lossless snubber with minimum voltage stress for continuous current mode tapped-inductor boost converters for high step-up applications. Journal of Power Electronics. 2014; 18(4): 621–31.
 18. Rishma AA, Rajeswari RP, Sasikumar M. High efficiency modified pulse width modulation bidirectional converters for medium power drives. IJAIEM. 2012; 1(2):94–100.
 19. Jung DY, Hwang SH, Ji YH, Lee JH, Jung YC, Won CY. Soft-switching bidirectional dc/dc converter with a lc series resonant circuit. IEEE Trans Power Electron. 2013; 28(4):1680–90.
 20. Lee JH, Yu DH, Kim JG, Kim YH. Auxiliary switch control of a bidirectional soft-switching dc/dc converter. IEEE Trans Power Electronics. 2013 Dec; 28(12):5446–57.