

IoT Based iPower Saver Meter

Nitin Sinha* and John Sahaya Rani Alex

School of Electronics Engineering, VIT University, Chennai – 600127, Tamil Nadu, India;
nitin03ece@outlook.com, jsranialex@vit.ac.in

Abstract

Background: An Internet of Things (IoT) based iPower Saver Meter which steps toward monitoring the total amount of power consumed by the domestic appliances. There by notifying the beneficiary a detail wise power consumption of appliances. Additionally provides, a configurable interface for user to limit the usage of high power consuming devices, such as Washing Machine, Air conditioner, etc. This facilitates user to set the timer on those appliances as per their affordability to check bulky increase in electricity bill. **Methods:** The sensing environment of the smart system is built upon BeagleBone Black board. The hardware environment is integrated with an IoT Platform called Xively and a secure web templates are designed using Flask interface. **Findings:** This platform yields a calibrated measurement of the power usage hence enabling the user to easily track down, by simply logging into Xively, the power consumption of every appliance and the current bill drawn from the usage. **Conclusion/Improvements:** The proposed intelligent power savor meter not only rectifies the inclining problem by providing a specified domain of power to be put under utility but also keeps a cautious vigilance over the area by turning off the devices which is running needlessly thereby saving surplus amount of wastage power.

Keywords: Beaglebone Black, Flask, IoT, Smart Power Meter, Xively

1. Introduction

The user's flexibility is the latest demand of the society, where a need of user requirement is to be fulfilled. Also with the incurring burden of over usage of resources has inspired the world to enact a mean to control the wastage of resources with less manual work involved. Resources like, power, fuel, performance, etc. have fulfilled the world's need in every sector. Hence governing the need of requirement at all cost is paramount. Therefore their effective usage is imperative by fully utilizing and avoiding unnecessary wastage of them. The current power metering system in every household, offices, school, university, etc. has the benefit of accurate measurement but the existing smart meters are not smart enough to save your electricity bill and avoiding high power consumption.

This paper provides an intelligent iPower saver meter which details the amount of power used in the house as

well as gives the versatility of setting limit across some high power consuming appliance such as Air Conditioner, Washing Machine, etc. such that the device can consume power within that scope of affordability, hence improving the power usage and ultimately reducing the electricity bill.

1.1 Technical Background

According to the current ongoing in the market, the smart meter will be a new generation meter that will be incumbent in every home in UK by 2020¹. The benefit of the smart meter is its accuracy in measurement of the home electricity usage which will render the end of overpaying (or underpaying) for energy, no one has to come to home for your meter reading and better oversight and management of your energy use with a real-time data display. But, the smart meter itself won't save money by cutting off the supply when there is absence of a person in the home

*Author for correspondence

and neither can it provide any flexibility to user to set a limit across some high consuming appliance for adequate amount of power usage thereby saving the money of the beneficiary. Whereas, in India where the consumption of electricity is relatively low and on the ground of world ranking India stands in 154th position in total of 200 countries². With such minuscule rating, around 27,000 MW of electricity goes waste every day in India that is around 27.15 % of the total production. Figure 1 Show the power consumption and their wastage for the fiscal year 2008 and 2009. Electricity generated in India comes almost from non-renewable sources (87.55%). Most of the power wastage occurs in colleges, hostels, office, hospitals, etc. where people use heavy electric appliances and mostly while leaving room people forget to switch off the lights and fans which count to the cumulative wastage of power.

Therefore the utility of iPower saver meter serves best in this abysmal situation to level the declining slope of power wastage which is rife in India. The proposed intelligent power savor meter not only rectifies the swathe of inclining problem by providing a specified ambit of power to be put under utility but also keeps a wary vigilance over the area by turning off the devices which is running unnecessarily thereby saving surplus amount of wastage which in India is abundant and undisputed.

1.2 Proposed System

The proposed system has been designed to provide maximum flexibility to the user by providing them an interface to check their status of power usage and electricity bill on daily basis. Also the user interface renders the user with facility to set timer over some high power consuming appliance. The central controller of the design takes the input from hall-effect sensor calibrate it to display the result in the IoT platform. Moreover, the user interface takes the user input and run the timer till the timer stops and signaling beaglebone black to change the status of suitable GPIO henceforth turning off the appliance in use. Figure 1 represents the block diagram of the system.

1.3 Organization of the Paper

Section 2 details about the calibration of Hall Effect sensor. Section 3 provides the hardware and software implementation detail. Section 4 provides the result snapshots and section 5 concludes the paper.

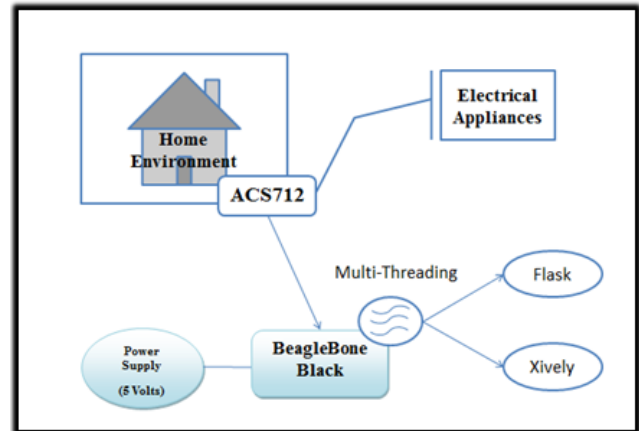

Figure 1. Block diagram of system.

2. Proposed Solution

2.1 Sensing Unit (Hall Effect Sensor ACS712)

Hall Effect sensor is used to sense the current flowing through the electrical appliances. The Hall Effect sensor consists of a magnet. The live wire used to connect the appliance is passed through the magnet. When the appliance is powered due to the current flowing in the wire, there is a magnetic induction due to which a small voltage is generated at the other end of the sensor.

The reading of the sensor had very large variable range, against the expected constant value. Hence because of this constraint value were taken in samples. Since 50 Hz is Indian operating frequency of every electrical appliance therefore 100 samples were taken per second. Each sample value was equated to root mean square value for better accuracy as shown in equation (1).

$$RMS = \sqrt{\frac{rms1^2 + rms2^2 + \dots + rms100^2}{100}} \quad (1)$$

The total RMS can be obtained by summing up the square of the individual RMS obtained per second and square rooting it. This is represented in the equation (2). Hence an accurate current value is procured.

$$Total\ RMS = \sqrt{\frac{RMS1^2 + RMS2^2 + \dots + RMSN^2}{N}} \quad (2)$$

Furthermore, Power was calculated by assuming some voltage value (Since the voltage sensor cannot be procured from the dealer, therefore unfortunately was excluded from the design and value was assumed). For voltage

sensor same procedure should be applied to obtain the accurate value. Also the pricing value has been assumed on per unit of power consumption and on simple multiplication electricity bill was generated.

3. Implementation

3.1 Hardware Implementation

The hardware in the design consists of beaglebone black, having ARM Cortex A8 processor core, as a central controller. TLC5940 IC has been used in the design to drive the Leds which makes it suitable for prototyping purposes. The use of L293 has been approached to control the speed of DC Fan via PWM of beaglebone black. Requirement of Hall Effect sensor ACS712 was accosted to measure the current flow in the electrical appliances. As in our design Led Bulb has been used. 16 x 2 LCD display has also been included in the design to provide in-home view of electricity bill and the net power consumption of the household. Figure 2 display the hardware and ICs employed in the design and Figure 3 show the hardware implementation of the design.

3.2 Software Implementation

Figure 4 signifies the Software layout of the proposed system. The software environment of the system is frameworked with python libraries. The hardware of the system runs in the multi-threading environment. One of the threads hosts the flask templates into the server while the other thread takes the responsibility of pushing the calibrated sensed value in the existing IoT Platform Xively. Being running parallel, Xively and Flask template, both the thread takes the input from the same Hall Effect sensor and displays the status of power consumed and electricity bill.

Flask is micro web framework for python which is based on Werkzeug and jinja². First, the system design includes a graphical representation of power and electricity bill. Second, timer based control for user’s flexibility in reducing electricity bill. Flask provides python to integrate with the html, JavaScript, CSS pages. Hence python running in the background hosts the web pages into the server. This pliability provides an ambit of scalability to put into the design thereby enlarging design to according to the future improvements. Figure 5 and Figure 6 shows the timer based control of the system.

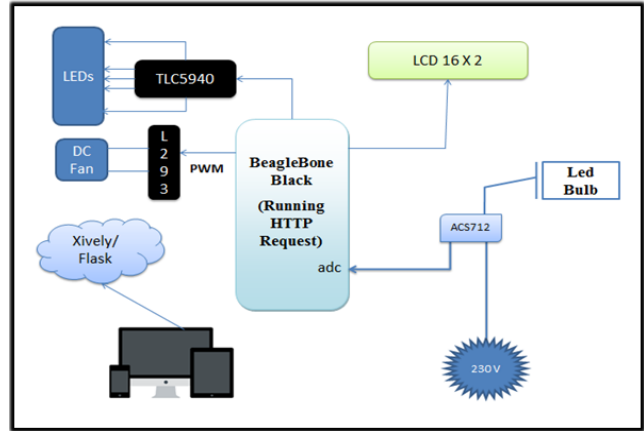

Figure 2. Hardware and ICs employed in the design.

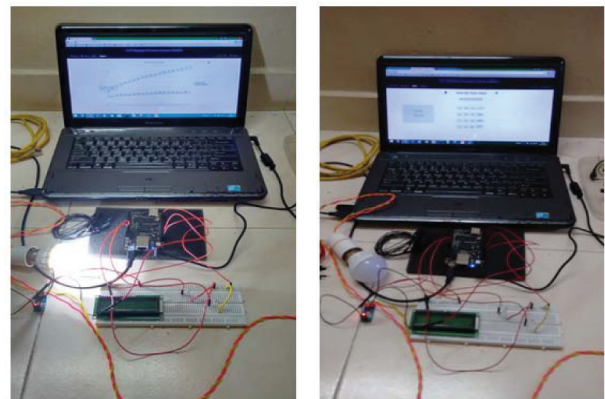

Figure 3. Hardware implementation of the design.

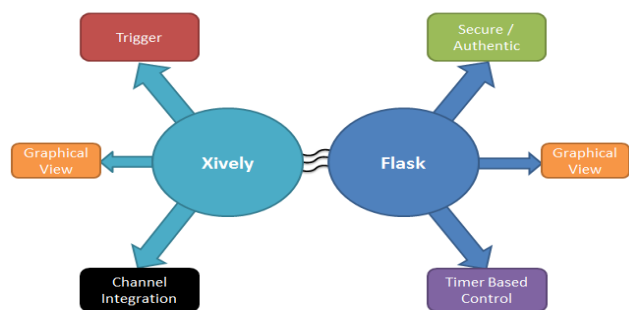

Figure 4. Software layout design.

Finally, flask template provides a secure and authentic connection to keep the unauthorized user a bay. If a user tries to access the page he/she is not authorized to access, the system permeability ceases. Figure 7 show how the software design of the system stalls the user to access the system.

Xively offers an IoT platform as a service which enables connection of sensors at the developer end and

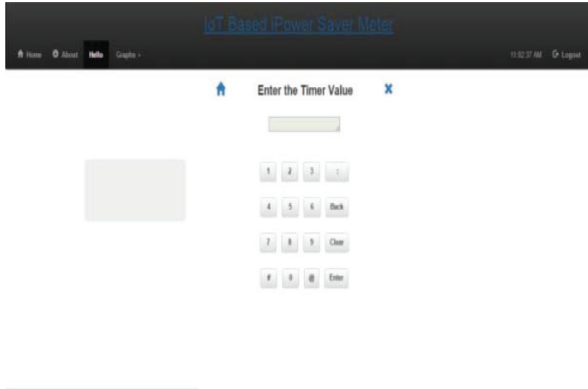

Figure 5. User interface for timer based control.

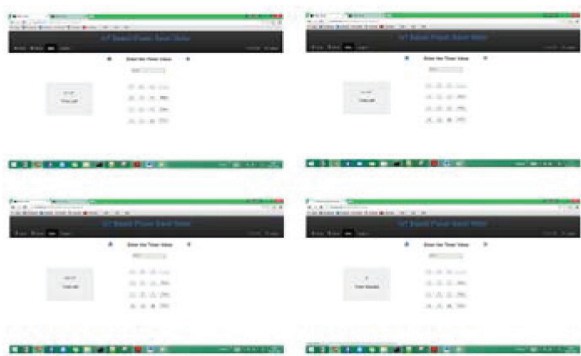

Figure 6. Timer running (Start and Stop).

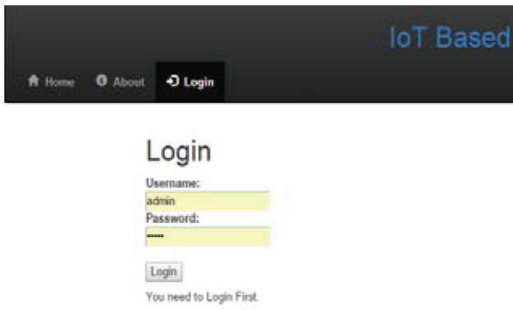

Figure 7. Secure and authentic design of the software.

deploy at the user end. Xively allows the access of channel through which desired sensor value can be configured. The channel forms an indispensable domain, by which Xively conduces toward creating a fruitful connection medium. Each channel created has a unique identification which is used by the software environment of the central controller to make an appropriate connection to the processed target sensor value. Figure shows the channel integrated with the sensor to display the result. Also one of the unique features about Xively is trigger, such that when a particular channel crosses a certain value of

threshold an alert message can be triggered to any social network or other network. Figure 8 represents the Xively channel.

4. Results

Figure 9 represents the live streaming graphical display of the power and Ebill status of the design. The source file and the supporting link of the graph have been taken from highcharts.com which is JSON based. Figure 10 displays the http request that has been fired for every value that has been streamed into the graph.

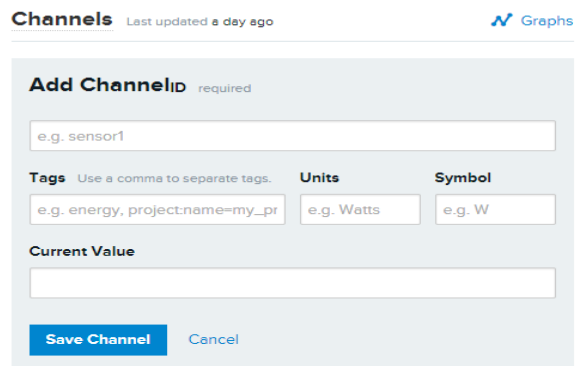

Figure 8. Xively channel.

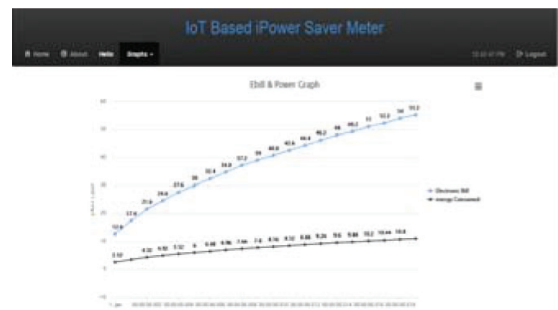

Figure 9. Control flow of the program.

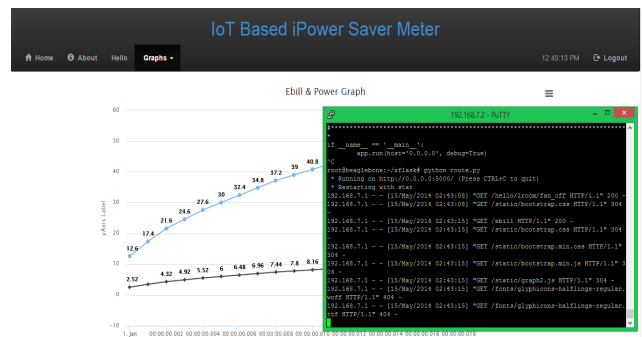

Figure 10. HTTP log request in flask.

Figure 11 shows the sensed value calibrated and processed by the Central controller and further which is integrated into the IoT platform Xively. Figure 12 presents the request method that has been logged after every value being pushed into Xively.

The above Figure 13 represents the Facebook developer account the app names as “IoT based iPower saver meter” is made in which authentication process is carried out. Once the authentication is finished it returns the app id and app secret key. Using those two entity Facebook integration can easily be done. Figure 14 shows the post alert is send to the user account if certain threshold is crossed.

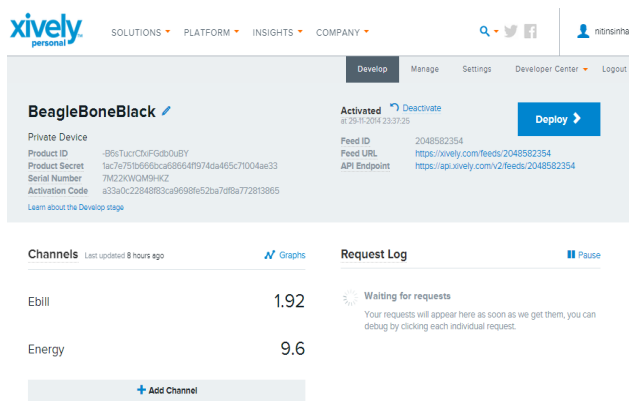

Figure 11. Calibrated sensor value being pushed into Xively channel.

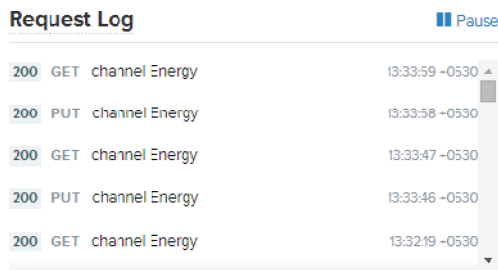

Figure 12. Request log in Xively.

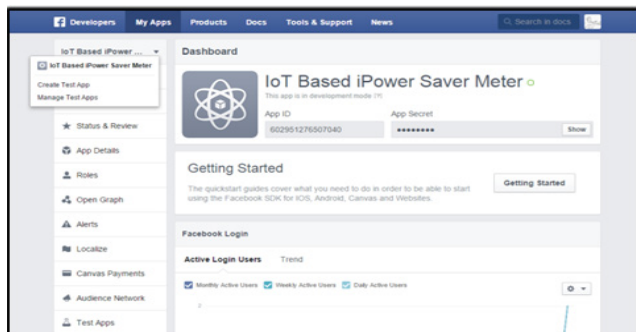

Figure 13. Facebook developer account.

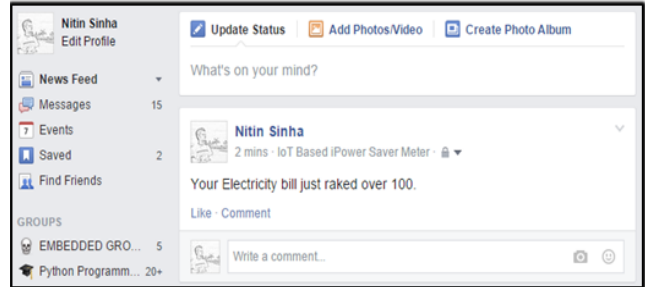

Figure 14. Facebook alert after a certain threshold is reached.

5. Conclusions

Although the existing power meter provides an accurate measurement of power utilized but it fails to reduce the electricity bill and save unwanted power usage. Therefore, the proposed intelligent power savor meter not only rectifies the swathe of inclining problem by providing a specified ambit of power to be put under utility but also keeps a wary vigilance over the area by turning off the devices which is running unnecessarily thereby saving surplus amount of wastage which in India is abundant and undisputed. With this product disseminated in every cities and town in India would impact in a way that the beneficiary would never have to wait for the electricity bill to monthly arrive. And he/she would just need to login into the server and get the power and bill details even if it is middle of the month. This, early details of bill would render the user to configure limit for bulky appliances as per their affordability. Consequently, this product would suit best in homes, offices, school/college (Laboratory), etc. where wastage of electricity is rampant.

6. References

1. Smart power meter 2015. Available from: <http://www.uswitch.com/gas-electricity/guides/smart-meters-explained/>
2. Stop electricity wastage 2015; Available from: <http://www.sharepdf.com/8b30497236824a93a9abadaf3095bcde/POWER%20USAGE%20AND%20WASTAGE.html>
3. Mishra A, Irwin D, Shenoy P, Kurose J. Smart charge: Cutting the electricity bill in smart home with energy storage. Proceedings of the Third International Conference on Future Energy Systems (e-Energy); Madrid, Spain. 2012 May.
4. Zhang Y, Wang Y, Wang X. Electricity bill capping for cloud scale data centers that impact the power markets. 41st

- International Conference on Parallel Processing (ICPP); Pittsburgh, PA. 2012 Sep 10-13. p. 440–9.
5. Moholkar A, Powsiri K, Feliachi A. Effect of dynamic pricing on residential electricity bill. Power System Conference and Exposition; 2004 Oct 10–13. p. 1030–5.
 6. Lumme J. Beagle bone home automation. Packt Publishing Limited; 2013 Dec 27.
 7. Xively Partner: Texas Instruments (TI). 2015; Available from: <https://xively.com/partners/ti/>
 8. Connecting wireless networks to the internet using Xively Technology. 2015; Available from: [http://www.atmel.com/](http://www.atmel.com/Images/Atmel-42275-Connecting-Wireless-Networks-to-the-Internet-using-Xively-Technology_AP-Note_AT07926.pdf)
 9. Weinberger M. Kohler M. Worner D, Wortmann F. Platforms for the internet of things – An analysis of existing solutions. 5th Bosch Conference on Systems and Software Engineering (BoCSE).
 10. Xively actually connects things in the internet of things. 2015 Available from: <http://readwrite.com/2013/05/14/xively-actually-connects-things-in-the-internet-of-things>