

Software Architecture for Streaming and Packet Loss Recovery Schemes in Road Monitoring Surveillance Camera Control Systems

Dinesh Kumar Saini¹ and Eimad Abusham²

Sohar University and University of Queensland, Oman; dinesh@soharuni.edu.om, eabusham@soharuni.edu.om

Abstract

Background/Objectives: This paper is about software architecture for security system design using surveillance control system. Various challenges are faced in surveillance control systems using monitoring cameras like packet loose, latency, quality of Closed-Circuit Television (CCTV) data, inconsistency and conflict among multiple sources etc. In this paper an attempt is made to solve some of the problems which are faced by surveillance control systems like road monitoring systems. **Methods/Statistical analysis:** Experimentation setup is proposed for the given software architecture and algorithm is developed for system. The Digital Video (DV) streaming system is a client-server model for the real-time delivery of DV streams over Internet Protocol (IP) networks based on Real-time Transport Protocol (RTP) / Real-time Transport Control Protocol (RTCP) protocol. The system includes two PCs, one at the server side and one at the client side, connected together with a Fast Ethernet LAN. Server has got a fire wire interface for capturing the data. Capturing device is connected to a DV converter (Canopus ADVC 1000) through a composite conversion cable. Converted DV stream is given to the server through IEEE 1394 interface. In the road monitoring systems such architecture is very much needed to recover from packet losses and it will help in reducing road accidents. **Findings:** In this paper attempt is made to propose the best possible architecture for arranging surveillance camera for getting the best streaming. Packet loss recovery schemes are proposed in the camera control systems which are used for monitoring roads and it can minimize the death rate using these monitoring camera systems. **Applications/Improvements:** The proposed software architecture is used in packet loss recovery systems of surveillance systems and very useful application for security systems which are used for monitoring road and it can reduce deaths caused due to road accidents.

Keywords: DV, HDV, Local Area Network, Packet Loss, Remote Camera Control, Streaming System

1. Introduction

According to World Health Organization each year nearly 1.5 million people die as a result of a road traffic collision—more than 3000 deaths each day. Twenty to fifty million more people sustain non-fatal injuries from a collision, and these injuries are an important cause of disability worldwide. Road traffic injuries are among the three leading causes of death for people between 5 and 44 years of age (www.who.int). Unless immediate and effective action is taken, road traffic injuries are predicted to become the fifth leading cause of death in the world, resulting in an estimated 2.4 million deaths each year. The

economic consequences of road insecurity have been estimated between 1% and 3% of the respective Gross National Product (GNP) of the world countries, reaching a total over \$500 billion. Situation is alarming and then there is need to study and analysis of the road accident causes and effects on the society and economy. The role of information technology in averting accidents and curbing the number of road accidents will be studied through the analysis of data. The following IT Systems to control road safety, like Fare and passenger control systems, Road Electronic Monitors, Display screens for public transport, Intelligent traffic control systems, Passenger traffic control systems, Traffic video monitoring systems, Navigation systems,

*Author for correspondence

and Signal control systems are deployed for surveillance. These systems generate tera bytes of data that need to be analyzed, not only to produce statistics but also to generate solutions to curb disastrous accidents. The analysis of this data will provide solutions to make road safe and also throw light on the ways to avert deaths and plight of victims in the aftermath of an accident¹. This data is rarely studied. Analysis of these data can shed light on how to discover, Hot Routes in Road Networks, Relation between Driver attention (and fatigue) and road accident through Fatality Analysis Reporting System, Effect of weather on the frequency and fatality of road accidents, Identify, target and reduce occupational road safety risks^{2,3}. The ultimate target of accident analysis issue is reduction of injuries and fatalities occurring as a result of road accidents. Here arrives the need for accident analysis with the implementation of various analytical techniques and by making use of the most modern techniques available in the computing field. Surveillance camera control systems can offer some solution for the current problem^{5,6}. On road Camera is installed on the highways which shows in Figure 1

The camera control system consists of a set of cameras located at different locations and the cameras are controlled remotely. End user is provided with a list of available cameras for selection. Once a camera is selected the data stream from the camera will be displayed at the user side. Camera control functionality is granted to the user if and only if



Figure 1. Oman road side.

the user is having the privilege to do⁶. CAMCON supports different media types including DV and HDV.

2. Objectives

- Design and develop a complete camera control system

The camera control system consists of a set of cameras located at different locations and the cameras are controlled remotely. End user is provided with a list of available cameras for selection. Once a camera is selected the data stream from the camera will be displayed at the user side. Camera control functionality is granted to the user if and only if the user is having the privilege to do it. CAMCON supports different media types including DV and HDV.

- Implementation of packet loss recovery schemes

This includes study of the existing streaming system and find out the reasons for packet loss in the systems and implement packet loss recovery mechanisms. Two different schemes are identified for DV and HDV streaming systems separately.

- Scheme 1 - Automated Repeat Request (ARQ) on HDV streaming system

The objective of the ARQ implementation is to devise a scheme to improve the playback performance of the streaming system in the event of packet loss⁶. The ARQ is implemented in HDV unicast mode streaming system.

- Scheme 2- Packet Loss Recovery Scheme for DV streaming system

In the case of DV, audio data requires stable and continuous rate of transmission. Hence For reliable transmission of DV data over the network, adding redundant data to the original data is a good solution^{7,9,27}.

- Analysis of ARQ efficiency

HDV streaming system is analyzed with and without implementing ARQ to check the efficiency of ARQ implementation.

- Comparison and DV and HDV Streaming systems¹²

The DV and HDV streaming systems are compared for parameters including bandwidth utilization and picture quality. Camera control system is shown in Figure 2.

The server application initiates a capture process through the IEEE 1394 card. The resulting IEEE 1394 encapsulated DV stream is RTP, packetized and transmitted to the client through UDP socket. Client side use Direct Show's filter graph technology for reception and playback of DV streams in PC monitor.

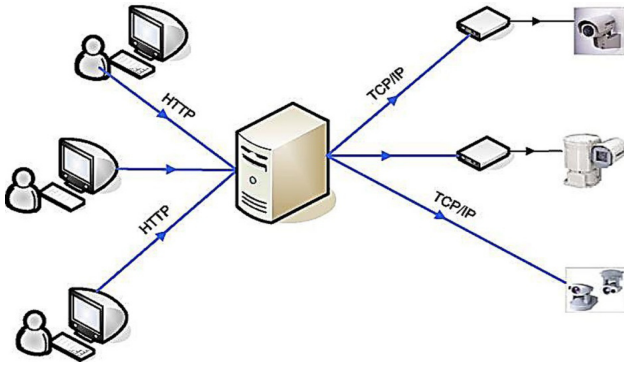

Figure 2. CAMCON system overview.

3. System Architecture

The Server application is composed of following filters:

Microsoft DV Camera and VCR filter: This filter provided by Microsoft, reads the DV data from the camera through fire wire bus (IEEE 1394 interface)^{10,15,16}.

DV Sender filter: DV sender filter is composed of two modules: RTP Packetizer module and DV Transmitter Module. RTP Packetizer module receives the DV data from the upstream filter “Microsoft DV camera and VCR” and applies a RTP wrapper to the DV data. The DV Transmitter module sends the RTP Packetized DV data to Network, Figure 3 shows the functional block diagram of the DV server.

The client module is composed of two filters, ‘DV Net Reader’ filter and ‘Microsoft DV Camera and VCR filter’. At the client side, the receiver component reads RTP packets at the receiving socket. The DV stream in RTP payload is extracted and is passed to downstream components¹⁷. The DV Splitter filter splits the Digital Video (DV) stream into its component video and audio streams. The DV video decoder filter decodes the DV video stream into uncompressed video. The uncompressed video stream is rendered to the PC monitor. The playback is seen in the client area of custom Media Player^{18,19}.

4. HDV Streaming System

HDV streaming system work based on client server architecture. The HDV Server receives the Transport Stream packets from a HDV camera through a Fire wire bus. The communication with the camera will be done using specific AV/C commands²¹. The HDV Server fragments these TS packets and forms RTP packets in accordance with RFC 2250 is given in Figure 4.

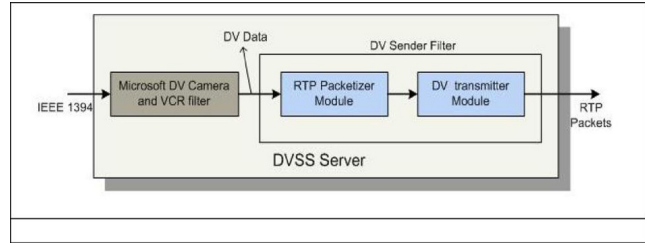

Figure 3. DV server functional block diagram.

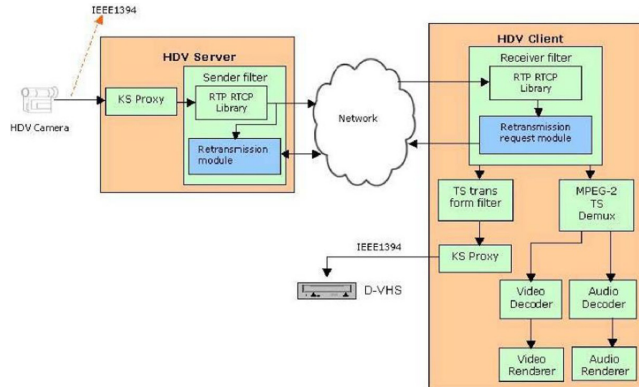

Figure 4. HDV server components.

The generated RTP packets are then transmitted by multicast / unicast. The HDV Filter Plug-In at the client-side will receive these RTP packets and extract the TS packets from them.

These are then handed down to a splitter or de-multiplexer respectively and the demultiplexer output is given to the decoders. Figure 5 depicts an overview of the Server Client system.

4.1 HDV Server: Customization

The new functionalities incorporated at HDV server side includes Buffering of sent packets

The RTP packets that are sent to the client are buffered at the server-side so that the server can resend these packets if it is requested to retransmit them. The size of the buffer is designed in such a manner to accommodate the “in-time” requirement by considering the Round Trip Delay (RTD) and other timing factors. Based on the client-side play-out buffer size, the server estimates the time for which the data in the buffer is valid. Servicing ARQ (re-send request) packets and Retransmission of packets

The retransmission of RTP packets will be done after considering the network-bandwidth and in-time validation.

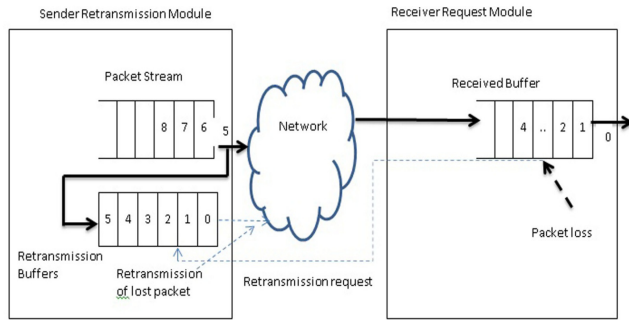

Figure 5. HDV server.

4.2 HDV Client- Customization

The new functionalities incorporated at HDV client side includes

- Detection of packet-loss

The client-side programs implements gap-based loss-detection to generate requests for retransmission. The sequence number provided by the RTP header is used to achieve the functionality. A gap is detected when a packet arrives with a sequence number higher than expected.

- Sending ARQ(re-send request) packets over RTCP

From the client-side, the retransmission-requests are validated based on factors like round trip delay and time left for playback.

- ARQ System High Level Design

ARQ Components are deployed at both the server-side and the client-side to provide the required ARQ functionality. A limited-functionality receiver component called Buffer-Handler is also be deployed at the server-side. The ARQ-Component at the server-side listens for retransmission-requests from the client. When it receives a request, it gets the requested RTP-data packets from the Buffer-Handler component and directly sends the requested RTP data packet to the client.

It shows in Figure 6, the ARQ-Component at the client side logs missing packets and sends retransmission requests to the server at predefined intervals. In this implementation RTCP channel is used to send the ARQ requests.

5. Server-Side

The server maintains a queue of retransmission buffers^{22,23}. The RTP packets will be queued in these buffers. The size of the queue depends on the play-out buffering maintained by the client. The information stored at the buffer

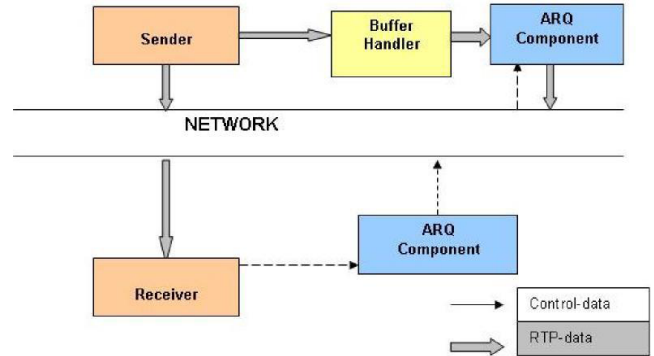

Figure 6. ARQ system.

is indexed with the sequence number. This information is obtained from the client at the time of connection start-up. Based on the client-side play-out buffer size, the server estimates the time for keeping the buffer before the data expires. The server handles the retransmission request from the client. The requested packets will be transmitted only if it is maintained in the retransmission buffer.

6. Client Side

The client side implements gap based loss detection to generate request for retransmission. This method uses the sequence number provided by the RTP header. A gap is detected when a packet arrives with a sequence number higher than expected. Gap detection on connection-less transport like RTP presents the problem of out of sequence packets. To handle this, method will be devised to treat out of sequence packet as lost packet. The client handles a queue for retransmission requests. Requests are made considering the following factors Conditional retransmission: The requests are based on whether the time left for presentation is less than the time required for a retransmission²³. A late request results in wasting network bandwidth and processing time^{3,8,20,14,24,25}.

Multiple retransmission requests: This is required since there is every chance of losing retransmitted packets. This method takes into account the conditional retransmission decision.

Consideration of request-packet loss: The chance for request-packet loss can also occur and this condition has to be handled. All retransmission requests contain information regarding the previous valid pending requests²⁶.

The main components of the ARMS-Client is

- Client Packet Handler

- ARQ
- Renderer
- Play out buffer
- Play out buffer

Packet Loss Detection – Pseudoce

The packet loss detection pseudo code is given below.

```

bStatus =Insert Without Dupe() // return true, if
inserted ,false if duplicate
if (bStatus) {
nSeqNoPos =Relative Position(nExpSeqNo, nRcvSeqNo, nRangeMax) // return 0(=) , 1 (>), -1(<)
if (nSeqNoPos = -1)
{ Update Lost List() //
}
}
else
if (nSeqNoPos = 1)
{
for(inti=1 to (nRcvSeqNo- nExpSeqNo)
{ Update Lost List()
}
}
}

```

Buffer Under-Flow - Pseudocode

In normal operation, it is assumed that the transmission rate and rendering rate are synchronized .But due to network congestion / error, the play out buffer can become empty .The following algorithm will be used to handle this problem.

```

If ( Buffer Empty() // detected buffer under-flow Reset
Rendering(); // stop rendering and wait till buffer full
While (! Buffer Full())
{
Receive RTP Packets();
Put Into Buffer();
}
Set Rendering();
}

```

4.2.3.3 Retransmission-requests to meet the in-time requirement – Pseudocode

The following technique is used to make sure that the retransmission-requests for packets that do not meet the in-time requirement

Input: Sequence Number of Current Packet Output: Removal from ARQ-list

- Find out last-known RTD, RTD Last
- Find out sequence number of packet being sent to Renderer, Sequence Number Of Render End Of Buffer Pool

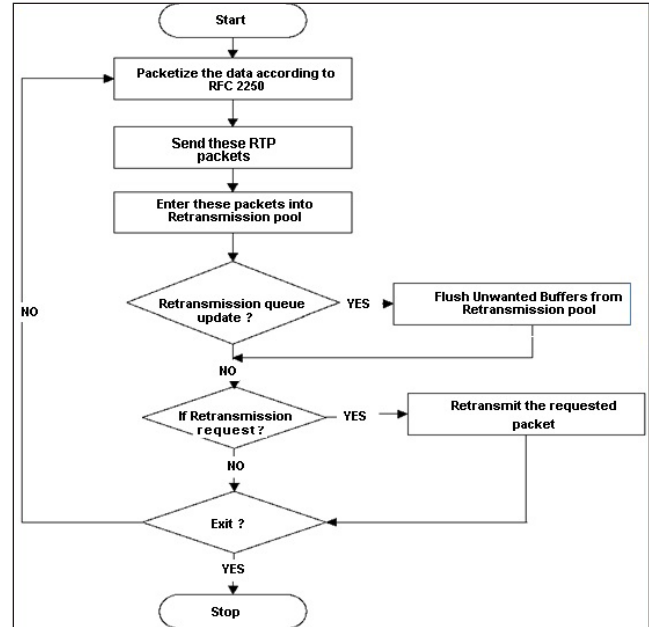

Figure 7. Flow chart: buffer under-flow – pseudocode.

- Find out playback rate, Play back Rate
- If Sequence Number Of Current Packet < (Sequence Number Of Render End Of Buffer Pool+ RTD/Playback-Rate) iv-a. Remove Current Packet from list for ARQ

7. Conclusion

In the paper we proposed real time streaming which is must for generating alerts and alarms for real time monitoring at critical places like airports, ports, roads etc. The system includes two PCs, one at the server side and one at the client side, connected together with a Fast Ethernet LAN. Server has got a fire wire interface for capturing the data. Capturing device is connected to a DV converter (Canopus ADVC 1000) through a composite conversion cable. Converted DV stream is given to the server through IEEE 1394 interface. In this paper attempt is made to propose the best possible architecture for arranging surveillance camera for getting the best streaming. Packet loss recovery schemes are proposed in the camera control system.

8. Directions for Future Work

The present work devised different schemes for packet loss recovery in DV and HDV streaming systems. The Audio redundancy scheme implemented for DV system

is not suitable for HDV streaming system. There is a scope to come up with a packet loss recovery scheme which can be applied streaming systems supporting different media types.

9. Acknowledgment

Author is thankful for Faculty of Computing and Information Technology Sohar University. Authors would like to thank RIC unit of Sohar University. We would like to thanks our colleagues at FCIT for valuable suggestions while preparing this paper.

10. References

1. Atrey PK, Hossain MA, Saddik AE, Kankanhalli MS. Multimodal fusion for multimedia analysis: a survey. *Multimedia Systems*. 2010; 16(6):345–79.
2. Bustamante AL, Molina JM, Patricio MA. A practical approach for active camera coordination based on a fusion-driven multi-agent system. *International Journal of Systems Sciences*. 2013; 45(4):741–55.
3. Rao DSB, Latha VS. The journey of Ethernet towards 1 TBPS and various fields of application. *Indian Journal of Science and Technology*. 2016 Mar; 9(11). DOI:10.17485/ijst/2016/v9i11/89293.
4. Daniyal F, TajM, Cavallaro A. Content and task-based view selection from multiple video streams. *Multimedia Tools Applications*. 2010; 46(2–3). p. 235–58.
5. Dieber B, Micheloni C, Rinner B. Resource-aware coverage and task assignment in visual sensor networks. *Institute of Electrical and Electronics Engineers (IEEE) Transactions on Circuits Systems and Video Technology*. 2011; 21(10):1424–37.
6. Ding C, Morye A, Farrell JA, Roy-Chowdhury AK. Opportunistic sensing in a distributed PTZ camera network. In *Proceedings of the 6th International Conference on Distributed Smart Cameras*. 2012 Oct 30 – Nov 1. p. 1–6.
7. Ding C, Song B, Morye A, Farrell JA, Roy-Chowdhury AK. Collaborative sensing in a distributed PTZ camera network. *Institute of Electrical and Electronics Engineers (IEEE) Transactions on Image Processing*. 2012; 21(7):3282–95.
8. Kanniga E, Selvaramarathnam K, Sundararajan M. Embedded control using mems sensor with voice command and CCTV camera. *Indian Journal of Science and Technology*. 2013 Jun; 6(S6):4794–6. DOI:10.17485/ijst/2013/v6i6/33965.
9. Fiore L, Fehr D, Bodor R, Drenner A, Somasundaram G, Papanikolopoulos N. Multi-camera human activity monitoring. *Journal of Intelligence Robotic Systems*. 2008; 52(1):5–43.
10. Selvaraj G, Kashwan KR. Reconfigurable adaptive routing buffer design for scalable power efficient network on chip. *Indian Journal of Science and Technology*. 2015 Jun; 8(12):1–9. DOI:10.17485/ijst/2015/v8i12/59145.
11. Garcia J, Carbo J, Molina JM. Agent-based coordination of cameras. *International Journal of Computer Sciences Applications*. 2005; 2(1):33–7.
12. Hodge L, Kamel M. An agent-based approach to multisensor coordination. *Institute of Electrical and Electronics Engineers (IEEE) Transactions on Systems Man Cybernetics Part A Systems and Humans*. 2003; 33(5):648–61.
13. Hu W, Hu M, Zhou X, Lou J. Principal axis-based correspondence between multiple cameras for people tracking. *Institute of Electrical and Electronics Engineers (IEEE) Transactions on Pattern Analysis Machine Intelligence*. 2006; 28(4):663–71.
14. Naidu KJ, Srikanth M. Design and verification of slave block in Ethernet management interface using UVM. *Indian Journal of Science and Technology*. 2016 Feb; 9(5):1–7. DOI:10.17485/ijst/2016/v9i5/87173.
15. Goswami K, Pandey B, Hussaian DMA, Kumar T, Kalia K. Input/output buffer based vedic multiplier design for thermal aware energy efficient digital signal processing on 28nm FPGA. *Indian Journal of Science and Technology*. 2016 Mar; 9(10):1–8. DOI: 10.17485/ijst/2016/v9i10/88072.
16. Nandhakumar N, Aggarwal JK. Integrated analysis of thermal and visual images for scene interpretation. *Institute of Electrical and Electronics Engineers (IEEE) Transactions on Pattern Analysis Machine Intelligence*. 1988; 10(4):469–81.
17. Paek I, Park C, Ki M, Park K, Paik J. Multiple-view object tracking using metadata. In *the Proceedings of the International Conference on Wavelet Analysis and Pattern Recognition*, Beijing. 2007; 1:12–7.
18. Pasqualetti F, Zanella F, Peters JR, Spindler M, Carli R, Bullo F. Camera network coordination for intruder detection. *Institute of Electrical and Electronics Engineers (IEEE) Transactions on Control Systems Technology*. 2013; 22(5):1669–83.
19. Seema A, Reisslein M. Towards efficient wireless video sensor networks: a survey of existing node architectures and proposal for a flexi-WVSNP design. *Institute of Electrical and Electronics Engineers (IEEE) Communications Surveys Tutorials*. 2011; 13(3):462–86.
20. Priyadharson SM, Joshua SV, Kumar CT. PLC – HMI and ethernet based monitoring and control of mimo system in a petrochemical industry. *Indian Journal of Science and Technology*. 2015 Oct; 8(27):1–5. DOI: 10.17485/ijst/2015/v8i27/72100.
21. Shen R, Cheng I, Basu A. Multi-camera calibration using a globe. In *Proceedings of the 8th Workshop on Omni*

- directional Vision, Camera Networks and Non-classical Cameras, Marseille, France; 2008 Oct.
22. Song B, Roy-Chowdhury AK. Robust tracking in a camera network: A multi-objective optimization framework. Institute of Electrical and Electronics Engineers (IEEE) Journal of Selected Topics in Signal Processing. 2008; 2(4):582–96.
 23. Song B, Ding C, Kamal AT, Farrell JA, Roy-Chowdhury AK. Distributed camera networks. Institute of Electrical and Electronics Engineers (IEEE) Signal Processing Magazine. 2011; 28(3):20–31.
 24. Song M, Tao D, Maybank SJ. Sparse camera network for visual surveillance: A comprehensive survey. Computer Vision and Pattern Recognition; 2013 Feb. p. 1–41.
 25. Soto C, Song B, Roy-Chowdhury AK. Distributed multi-target tracking in a self-configuring camera network. In Proceedings of the Institute of Electrical and Electronics Engineers (IEEE) Conference on Computer Vision and Pattern Recognition (CVPR) , Miami, FL; 2009. p. 1486–93.
 26. Spaan MTJ, Lima PU. Decision-theoretic planning under uncertainty for cooperative active perception. In Proceedings of the NIPS Workshop on Adaptive Sensing, Active Learning and Experimental Design, Canada; 2009. p. 2.
 27. Sankaradass V, Khan ZF, Suresh G. Tracking and recognizing gestures using TLD for camera based multi-touch. Indian Journal of Science and Technology. 2015 Nov; 8(29):1–6. DOI:10.17485/ijst/2015/v8i29/78994.