

Gesture Controlled Robotic Arm using Leap Motion

Sarmad Hameed*, Muhammad Ahson Khan, Bhawesh Kumar, Zeeshan Arain and Moez ul Hasan

SZABIST, 90 and 100 Clifton, Kehkashan – 75600, Karachi, Pakistan; sarmad.hameed@szabist.edu.pk, ahsonkhan73@gmail.com, bhaweshrathi08@gmail.com, zee.arain07@hotmail.com, moez.hassan@szabist.edu.pk

Abstract

Robot plays a vital part in making our lives more facile. The scope of this paper is to provide a relation between human and machine by the interaction of human hand and robotic arm. The idea converges towards the conception of a robotic arm identical to human hand with gesture that is more precise. The arm consists of five Degree of Freedom (DOF) and an end effector, which allows the interaction with the real world. The construction of the robotic arm adapts the principles of inverse kinematics and torque equilibrium. Now the obligations for the controller arise and along the way settled with the exploration of leap motion sensor. As earlier, robotic arm was controlled by the keypad or joystick which required a lot of practices and calculations to manipulate the robotic arm to reach desired position. The exploitation of the leap motion results in explicitly acquiring for hand gesture and provides set of points. This innovation enables more perceptive five DOF control with an end effector. The results showed the reduction in the complexity approach and gain in control accuracy.

Keywords: Forward Kinematics, Gesture Control, Leap Motion, Robotic Arm

1. Introduction

These days, robots became an availing hand for human being. Robot can perform any task with more precision and accuracy. This is very difficult to perform for human being in very less amount of time, such as used in industries for war heads, surgeries, placing heavy parts agriculture field in case of hazardous conditions, for land mine detection, bomb disposal etc. since the invention of first robot ever a mechanical steam-operated bird “the pigeon” which was designed by a Greek mathematician “archaist” for about 2300 years back. Archaist designed this bird out of wood and powered its movement through steam; it was able to fly up to 200 meters before it runs out of steam¹. Even though in the field of medical surgeries robots have shown their vital role in the form of ‘da Vinci Surgical system’, it is a manipulator with multiple robotic arms, which grant doctor to operate from a safe distance with the help of a joystick. The ‘da Vinci’ allows into consideration of a quicker and more exact surgery².

Now days, due to the advancement of technology robots can even explore without relying on a human. They have replaced human beings in extreme work conditions,

which are dangerous for human beings to perform, as in industries due to the use to robots the productivity rate has increased tremendously. The advancement of robotics have also been used in our daily life and in helping of aged people, as elderly people face difficulty in performing daily life activities. Activities of Daily Living (ADLs) represent the everyday tasks individual usually ought to be ready to severally accomplish³. People with injuries i.e. Upper limb injury, spinal injury, Polio, hemiplegia face problems in performing ADLs using human-computer interfaces technology several attempts have been made to propose stroke rehabilitation system by human-computer community, at last an interactive glove has been proposed for the stroke rehabilitation. This system includes exercises as curling of fingers, moving hand back and forth. The most common approach to create an interactive system is to perceive the motions from profundity information without processing the full posture, by applying machine learning strategies to some significant components removed from the depth data¹. Mainly most of the field of technology uses robots these days i.e. field of surgeries, medical rehabilitation, manufacturing industries, bomb diffusion etc.

*Author for correspondence

In mostly every field of robotics 5 or 6-dof robotic arm is utilized in making our task easier, the robots do not require any human interaction but in some cases robots are to be manually controlled to perform certain tasks which were not programmed initially. Bomb disposing, space and military mission and medical rehabilitation require manual controlled robots to perform real time operations. Thus, a need to actuator arises to control the arm. A robotic arm constructed with diverse joints that replaces human arm joint. These entire joint driven by motor inside it, which is operated by a controller⁴. The controller is made up of set of joystick to control each joint of the robotic arm. For the robot to come to its position we need to figure certain angles which is laborious task, we need a bilateral system, which is better than the joystick control. The most recent technology of the Leap Motion sensor has opened new doors for gesture recognition⁵.

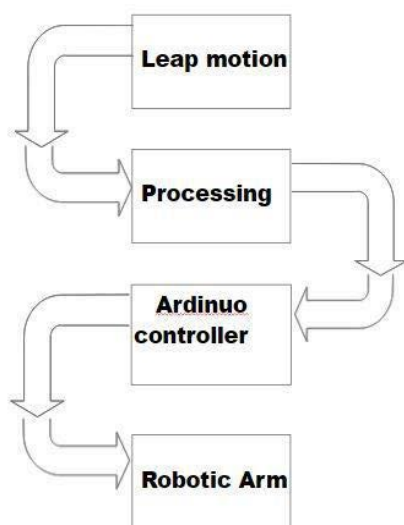

Figure 1. Process diagram.

Using principles of electromyography, (emg) this device directly locates the position of the fingertip and hand orientation using a led infrared sensor and a small two digital cameras to detect the movement of hand and fingers.

This paper goes through the attempt of movement of robotic arm through the acquired data by leap motion. It mimics the human hand movement, which makes the real time controlling of the robotic arm friendlier than ever before. The process of the system is shown in Figure 1.

The paper is coordinated as follows: Section 2 contains research methodology. Section 3 proposed the concept of work. Section 4 described hardware and software implementations. Section 5 demonstrates results and efficacy of system. Section 6 concludes the complete paper.

2. Research Elaborations

2.1 Controller

The controller is a hardware device or a software program that controls the flow of data between two entities. In general, a controller thought an object that interfaces or communicates between two systems. As per for robotic arm, exactly many buttons and joystick manipulators are available for the operator to understand. As humans cannot determine the required joint angles as expeditious as computer, it would be tedious for a human being to bring robotic arm to a specific position through a controller as shown in Figure 2.

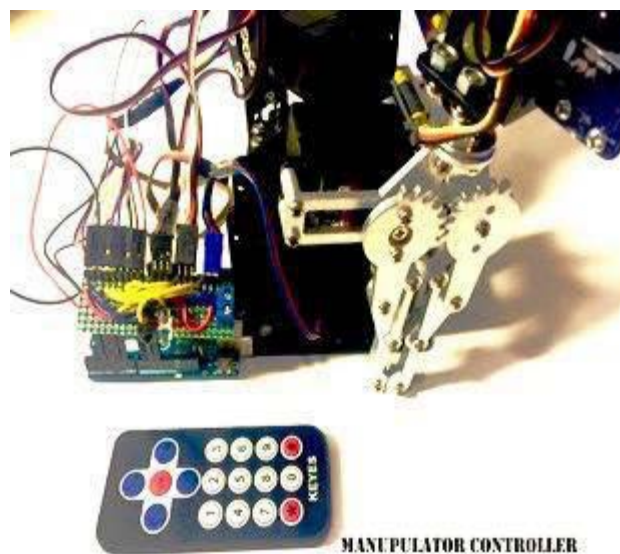

Figure 2. Joystick controlled robotic arm.

From Figure 2, it is conspicuous that these controls are complicated for a manipulator to control. We need a controller, which can consume less time with more accuracy, the best way would be to imitate the hand movement and the solution arises with the sensor named as leap motion. A new way anticipated by which computer can easily be operated is by wave of a hand or lift of a finger⁶.

2.2 Leap Motion Controller

In the world of computing, leap motion is one of its kinds. A leap motion is a controller that detects the movement of a human hand. The leap motion controller is a little USB fringe contrivance, which brings controlling of virtual reality into being, Utilizing two monochromatic IR cameras and three infrared LEDs; as shown in Figure 3 the gadget watches a generally hemispherical range, to a separation of around 1 meter⁴. As the hand movement are detected 3 infrared emits light with the wavelength of 850 nm. The leap motion sensor has definitely diminished in estimate throughout the years. Jump Motion has lessened to a minimal size of 13 mm x 13 mm x 76 mm and just weighs 45 grams².

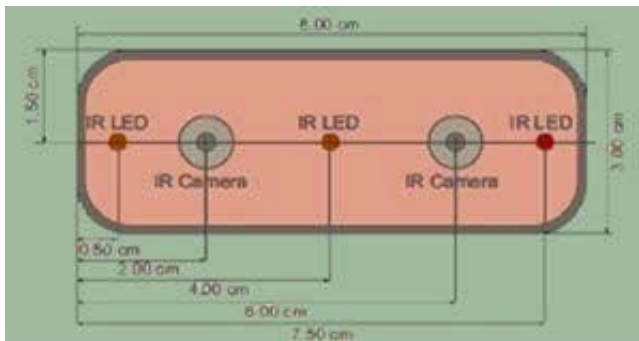

Figure 3. Internal leap motion structure.

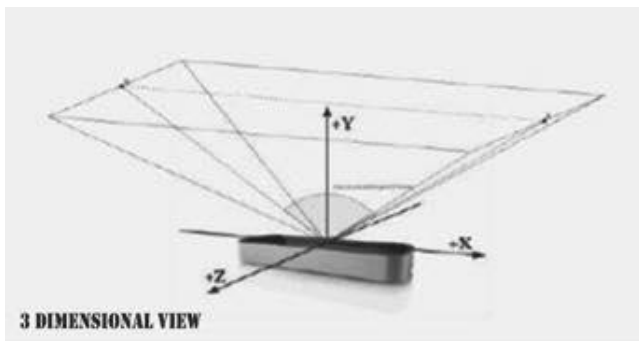

Figure 4. Leap motion dimensional view.

The data that retrieved from the leap motion contains various informations from the positioning frame id to the detection of bones and fingers. Leap motion can detect a human hand within the distance of one millimeter and consuming time to be 300 second. As per for these information leap motion is a good choice to be integrated with the robotic arm. A leap motion provides an average accuracy of 0.7 millimeters to detect the human hand, the

mono chromatic sensors detects the heat emits from the human hand and infrared led detect the structure and of the sensor is based on the right-hand Cartesian coordinate system, with the origin centered at the top center of the device².

As shown in the Figure 4 leap motion sensor works in 3D coordinates (X, Y, Z). After the obligation of the position of a human hand the data is then send to the Pc or controller due to the reason that the machine does not know how to get to the specific position¹. The controller converts the data obtained from the leap and convert it into coordinates onto which robotic arm can move.

3. Proposed Concept

After the implementation of the graphing the prose on the manipulation of the objects, the design of such a robotic arm is proposed that can mimic the hand movement of the user conveniently. The proposed concept depends on what is so called a more “natural” human-robot interaction¹¹. Such robot will have benefits of performing in complex task as soft robotics, bomb disposal squad, medical sugary etc.

3.1 Process diagram

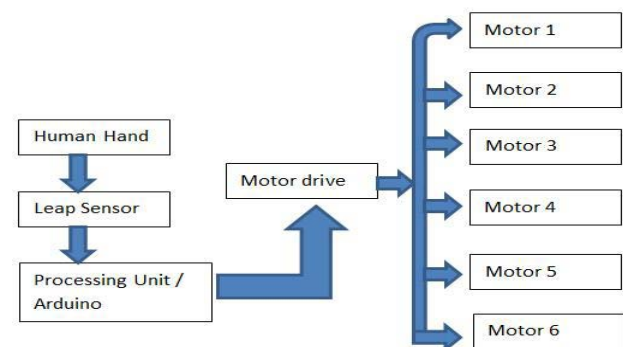

Figure 5. Steps taken to complete the project.

Leap sensor will start detecting hand and its movement of arm, wrist and fingers. When the hand does any movement it will detect the movement and process its movement and send it to motors working at our robotic arm for wrist to fingers movement. The hand movement will be transmitted wirelessly to our robotic arm. Wireless communication will help in distance communication which will increase the efficiency and application of the project.

4. Implementation

The robotics provides an efficient glide path in the development of assistive devices. The product configuration for the most part spins around the programming of the microcontroller and jump movement. The Arduino microcontroller is an open-source single-board microcontroller which is customized in C or C++⁹. They are used in controlled system applications such as automated devices, remote controls, machines and other embedded systems¹⁰. The essential concept is here to introduce the implemented system of a robotic arm based on a hand mimic gesture.

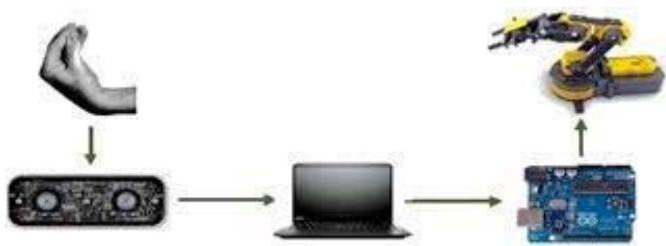

Figure 6. Steps taken to complete the project.

Table 1. D-H Parameters 6 DOF Robotic Arm

Frame	α_{i-1}	a_{i-1}	d_i	θ_i
0-1	0	0	0	θ_1
1-2	90	0	0	θ_2
2-3	0	L_3	0	θ_3
3-4	0	L_4	0	θ_4
4-5	-90	0	0	θ_5
5-6	90	0	0	θ_6

4.1 Mechanical Design

In the world of robotics inverse kinematic refers to the conversion of the berth and orientation of the robot manipulator end-effector from Cartesian blank to joint space. It can also be defined as the stipulation of the drive of the robot so that its end-effector achieves a desired position known as motion planning⁷. Inverse kinematics transforms the joint angles that will place the end-effector in the destination frame. Inverse kinematics plays a vital role in identifying and calculating the path of the robotic arm from the ‘universal’ frame using mathematical equa-

tion of the robot. Degree of Freedom and length of the joint are the obligatory parameter that is required in order to calculate inverse kinematics equation of the particular robot. The parameter varies from one another.

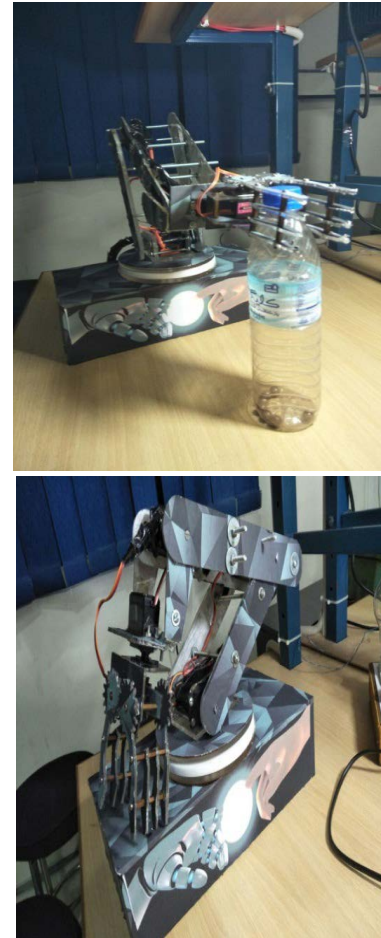

Figure 7. Final design of the project.

The forward kinematic equations of the manipulator shown in Figure 7 are as follows:

Symbol Terminologies:

θ : Rotation about the z-axis.

d : Distance on the z-axis.

a : Joint offset.

α : Joint twist.

Only ‘ θ ’ and ‘ d ’ are joint variables.

First we create the joint coordinate frames by the D-H convention. The link parameters are shown in the Table 3.1.

It is straightforward to compute the transformation matrices which is represented by ‘ T ’ as:

General Equation matrix:

$$T = \begin{pmatrix} \cos\theta_i & -\cos a_i \sin\theta_i & \sin a_i \cos\theta_i & a_i \cos\theta_i \\ \sin\theta_i & \cos a_i \cos\theta_i & -\sin a_i \cos\theta_i & a_i \sin\theta_i \\ 0 & 0 & \cos a_i & d_i \\ 0 & 0 & 0 & 1 \end{pmatrix}$$

Therefore, the resulting matrix multiplication calculates the final transformation matrix, which gives the position and orientation of the robot's end effector with its base.

Joint transformation is defined as follows:

Base Joint:

$${}^0_1T = \begin{bmatrix} C\theta_1 & -S\theta_1 & 0 & 0 \\ S\theta_1 & C\theta_1 & 0 & 0 \\ 0 & 0 & 1 & 0 \\ 0 & 0 & 0 & 1 \end{bmatrix}$$

Shoulder Joint:

$${}^1_2T = \begin{bmatrix} C\theta_2 & -S\theta_2 & 0 & 0 \\ 0 & 0 & -1 & 0 \\ S\theta_2 & C\theta_2 & 0 & 0 \\ 0 & 0 & 0 & 1 \end{bmatrix}$$

Elbow Joint:

$${}^2_3T = \begin{bmatrix} C\theta_3 & -S\theta_3 & 0 & L_3 \\ S\theta_3 & C\theta_3 & 0 & 0 \\ 0 & 0 & 1 & 0 \\ 0 & 0 & 0 & 1 \end{bmatrix}$$

Wrist Joint (rotation):

$${}^3_4T = \begin{bmatrix} C\theta_4 & -S\theta_4 & 0 & L_4 \\ S\theta_4 & C\theta_4 & 0 & 0 \\ 0 & 0 & 1 & 0 \\ 0 & 0 & 0 & 1 \end{bmatrix}$$

Wrist Joint (roll):

$${}^4_5T = \begin{bmatrix} C\theta_5 & -S\theta_5 & 0 & 0 \\ 0 & 0 & 0 & 0 \\ -S\theta_5 & -C\theta_5 & 0 & 0 \\ 0 & 0 & 0 & 1 \end{bmatrix}$$

Gripper:

$${}^5_6T = \begin{bmatrix} C\theta_6 & -S\theta_6 & 0 & 0 \\ 0 & 0 & 1 & 0 \\ S\theta_6 & C\theta_6 & 0 & 0 \\ 0 & 0 & 0 & 1 \end{bmatrix}$$

It can be started with the base of the robot which is joint 1 and then it transform to the joint 2, then to the joint 3 until to the end effector of the robot.

Total transformation between the base of the robotic arm and the hand is

$${}^1_6T = {}^1_2T * {}^2_3T * {}^3_4T * {}^4_5T * {}^5_6T$$

By multiplying these transformation matrices we get final equation of transformation:

$${}^1_6T = \begin{bmatrix} R_{11}R_{12}R_{13}R_{14} \\ R_{21}R_{22}R_{23}R_{24} \\ R_{31}R_{32}R_{33}R_{34} \\ R_{41}R_{42}R_{43}R_{44} \end{bmatrix}$$

Where

By multiplying we get,

$$R_{11} = -c_{12356} + c_{1256}s_{34} - c_{124}s_{34} - c_{123}s_{46} + c_{1356}s_{24} - c_{134}s_{26} + c_{1s2346} + c_{1456}s_{23} - c_6s_{15} \tag{1}$$

$$R_{12} = c_{135}s_{462} - c_{145}s_{362} + c_{16}s_{342} - c_{1346}s_2 - c_{1326}s_4 + c_{13245}s_6 - c_{12}s_{3456} - c_{1246}s_3 + s_{156} \tag{2}$$

$$R_{13} = c_{134}s_{52} - c_{12}s_{2345} - c_{13}s_{245} + c_{14}s_{235} - s_{1c5} \tag{3}$$

$$R_{14} = c_{123}L_4 + c_{12}L_3 - c_{1s23}L_4 \tag{4}$$

$$R_{21} = -c_{2356}s_1 + c_{256}s_{134} - c_{24}s_{136} - c_{23}s_{146} + c_{356}s_{124} - c_{34}s_{126} + s_{12346} + c_{456}s_{123} + c_{16}s_5 \tag{5}$$

$$R_{22} = c_{35}s_{1246} - c_{45}s_{1362} + c_6s_{1234} - c_{346}s_{12} - c_{236}s_{14} + c_{2345}s_{16} - c_2s_{13456} - c_{246}s_{13} - s_{56}c_1 \tag{6}$$

$$R_{23} = c_{34}s_{152} - c_2s_{1345} - c_3s_{1245} + c_4s_{1352} + c_{15} \tag{7}$$

$$R_{24} = c_{23}s_1L_4 + c_2s_1L_3 - s_{123}L_4 \tag{8}$$

$$R_{31} = -c_{3456}s_2 + c_{56}s_{234} - c_4s_{236} - c_3s_{246} - c_{2356}s_4 + c_{234}s_6 - c_2s_{346} - c_{256}s_{234} \tag{9}$$

$$R_{32} = -s_{24}c_{36} + s_{26}c_{345} - s_{23456} - s_{23}c_{46} + s_{46}c_{235} + s_6c_{452} - s_{34}c_{62} + c_{3461} \tag{10}$$

$$R_{33} = s_5 c_{234} - s_{2345} c_2 + s_{45} c_{32} + s_{35} c_{42} \tag{11}$$

$$R_{34} = s_2 c_3 L_4 + s_2 L_3 + c_2 s_3 L_4 \tag{12}$$

$$R_{41} = R_{42} = R_{43} = 0 \tag{13}$$

$$R_{42} = 1 \tag{14}$$

where

$$c_{123456} = \cos \theta_1 \cos \theta_2 \cos \theta_3 \cos \theta_4 \cos \theta_5 \cos \theta_6$$

and so forth

$$s_{123456} = \sin \theta_1 \sin \theta_2 \sin \theta_3 \sin \theta_4 \sin \theta_5 \sin \theta_6$$

4.2 Hardware Design

As the motors consist of six servomotors connected to the robotic arm with the respected required torque. The hand gesture is acquired by the leap motion is then transmitted to the mechanical arm and mimics the gesture position. The equipment comprises of a straightforward open equipment plan for the Arduino board⁹. The motors used in the movement of a robotic arm, are as follows:

Generally, the mechanical arms utilize Servo moto's for activation because of its consolidated advantage of exactness, accuracy and torque over ordinary DC/AC engines¹².

- Base: mg996R tower pro
- Shoulder: cys-s8218 digital servo
- Elbow: 1501mg-analog servo
- Wrist: futaba-s3003
- Wrist rotation: futaba-s3003
- Gripper: SG-90 mini

4.3 Software Design

API (Application Program Interface) is as semblance of different programming languages that used by the developers to access the processes. The API of leap motion provides us all the possible opportunities to interact with the controller and sensor for retrieving the input values through hand for processing inverse kinematics⁷. Many languages are used for controlling leap motion such C#, JAVA, python etc., Using C# as API we created interactive communication between sensor and robotic arm, Using a C# program which track the manipulator's hand movement by mean of mapping through leap motion.

The code used to control the manipulator gets the three-dimensional hand position of the manipulator and

sends it ahead for the controller to convert it into degrees. The code repeatedly gets the values and calculates forward kinematics. This approach can be targeted with different robots with any Degree of Freedom. It justifies that this is the most obvious, smooth and simple way to handle a robotic arm in real time.

5. Results

We have constructed a demo to show the predominance of our strategy, all things considered, applications. The graphs reading from that application is submitted below:

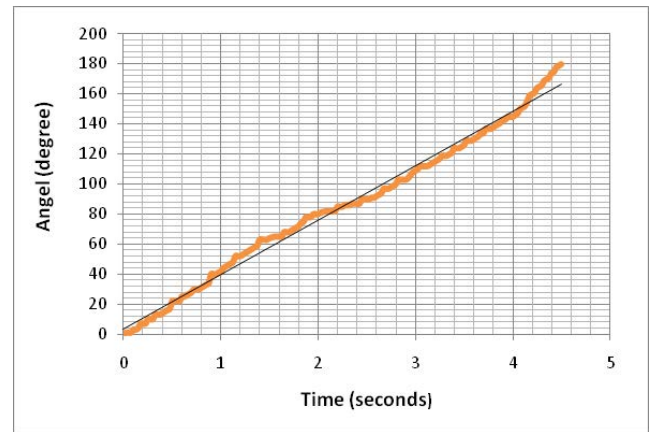

Figure 8. Graph of robotic arm.

Figure 8 contains the graph of angles in degrees versus time in seconds by the robotic arm.

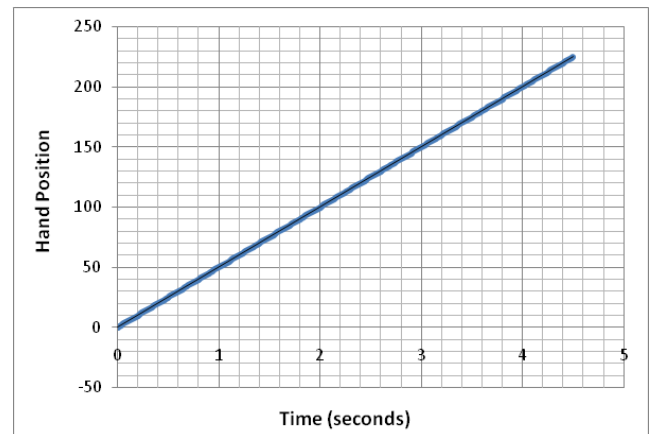

Figure 9. Graph of human hand

Figure 9. The graph of angular position of hand in degrees versus time in seconds.

By comparing the graphs of Figure 8 and Figure 9 we conclude that the robotic arm follows the human hand with less error.

6. Conclusion

As reaching towards the conclusion, Gesture control commence to be one of the simplest and easy way by with a complex robot could be controlled easily, with the help of different sensors and among them is the leap motion sensor. It helps to build the inactive way of communication between the human hand and robotic arm with the help of few mathematical equations. This system can be utilized in the field of robotics where reduction of lot of effort and manual control is needed. The main object to study this system is to keep in mind the end goal to empower the embodiment of a mechanical system in to the home surroundings, to improve the self-governance and freedom of individuals with rigorous mobility disabilities and to concede at the same the tracking and aversion of eccentric disorders. The initial design used for the hand was very effective but due to the limitation used in the system also limited the efficiencies of the system. The experimental results conclude that the system can detect hand gesture efficiently in real time and execute accordingly. As for future development it is considered that leap motion technology will definitely benefit and enable new ways to human-machine interaction in the field of ADLs and AAL due to its size and efficiency.

7. References

1. Trinadh VSNV, Sarosh P. Real-time robot control using leap motion. 2015 Northeast Section Conference of the American Society for Engineering Education (ASEE); Boston. 2015.
2. Connor B, Maria C, Pengfei T. Real-time control of robot arm based on hand tracking using leap motion. E-project-012415-140406; Shanghai, 2015.
3. Bassily D, Georgoulas C, Guettler J, Linner T. Intuitive and adaptive robotic arm manipulation using the leap motion controller. ISR/Robotik 2014; Munich: 41st International Symposium on Robotics; 2014.
4. Navneetlal BW, Rahul MP, Namrata SN Eknath SS. Hand gesture controlled robotic arm. International Journal on Recent and Innovation Trends in Computing and Communication. 2016; 4(4):435–7.
5. Giulio M, Fabio D, Pietro Z. Hand gesture recognition with leap motion and kinect devices. 2014 IEEE International Conference on Image Processing (ICIP); Paris. 2015.
6. Bizzotto N, Costanzo A, Bizzotto L, Regis D, Sandri A, Magnan B. Leap motion gesture control with OsiriX in the operating room to control imaging. Surgical Innovation, 2014; 21(6):655–6.
7. Fabio D, Mauro D, Giulio M, Pietro Z, Guido MC. Hand gesture recognition with depth data. 4th ACM/IEEE International Workshop on Analysis and Retrieval of Tracked Events and Motion in Imagery Stream; Barcelona. 2013.
8. Junsong Yuan ZR, Zhang Z. Robust hand gesture recognition based on finger-earth mover's distance with a commodity depth camera. 19th ACM International Conference on Multimedia; Scottsdale. 2011.
9. Saquib SMT, Hameed S, Ali SMU, Jafri R, Amin I. IOPscience. IOP Publishing Ltd, 2013. <http://iopscience.iop.org/article/10.1088/1757-899X/51/1/012025/meta>
10. Rashied Z, Hamees M, Hassan MU, Hameed S, Khatri NA. International Journal of Conceptions on Information Technology and Computing. 2016; 4(2).
11. Narayanan S, Reddy CR. Bomb defusing robotic arm using gesture control. IJERT. 2015; 4(2):89–93.
12. Sancheti AK. Gesture Actuated Robotic Arm. International Journal of Scientific and Research Publications. 2012; 02(12):1–6.