



A Review on Energy Efficient Communication in Cognitive Wireless Sensor Networks

Shobhit Verma¹, Vikas Raina², Partha Pratim Bhattacharya³

¹Research Scholar, Department of Electronics and Communication Engineering, Mody University of Science and Technology, Lakshmangarh, Sikar, Rajasthan-332311

²Assistant Professor, Department of Electronics and Communication Engineering, Mody University of Science and Technology, Lakshmangarh, Sikar, Rajasthan-332311

³Professor, Department of Electronics and Communication Engineering, Mody University of Science and Technology, Lakshmangarh, Sikar, Rajasthan-332311

¹shobhitteachingmaterial@gmail.com, ²vikasraina.cet@modyuniversity.ac.in, ³hereispartha@gmail.com

Received 19 Dec. 2017, Published 23 Feb. 2018

Abstract: Nowadays, Wireless Sensor Networks faces the problem of spectrum unavailability as it has to share spectrum with contemporary technologies like Bluetooth, Wi-Fi etc. To overcome this problem Cognition is added in Wireless Sensor Networks which results in Cognitive Wireless Sensor Networks. The sensor nodes in Cognitive Wireless Sensor Networks have a spectrum sensing capability which gives an opportunity to an Unlicensed user to transmit in the licensed band whenever the spectrum have not been used by Licensed user. In other words, Cognitive Wireless Sensor Networks deals with the problem of spectrum unavailability. Spectrum Sensing and similar parameters decays the lifetime of the sensor nodes which in turn decreases the efficiency of sensor nodes. This review paper shows the way that how an energy efficient communication in Cognitive Wireless Sensor Networks can be modeled. Various parameter effects the lifetime of the sensor nodes. Probable solutions like energy harvesting and energy efficient routing will be discussed for increasing the life time of the sensor nodes. Future challenges and research areas for developing an energy efficient communication system for Cognitive Wireless Sensor Network are also discussed.

Keywords: Cognitive Wireless Sensor Network, Sensor Nodes, Spectrum sensing, Energy Efficient

1. INTRODUCTION

For the proper implementation of the dynamic spectrum access strategy, Cognitive radio (CR) technology has been proposed. The problem of spectrum deficiency can be tackled by using dynamic spectrum access strategy. For Wireless Networks, radio spectrum is the most readily available resource. By using Cognitive Radio technology, the earlier used static spectrum allocation strategy is slowly but efficiently been replaced by dynamic spectrum allocation strategy. Cognitive compatible devices are smart devices that have the ability to sense environmental changes and they can also vary its constraints according to the needs to have the optimized performance at each node in the Wireless Network. Cognitive radio technology allows the Secondary or Unlicensed user to use the spectrum that was initially assigned to Primary or Licensed users as per the availability [1].

The basic characteristic of Cognitive Radio is to gather information like bandwidth size, modulation type etc and reconfigure in accordance with the gathered information. Due to these features Cognitive Radio has become the new vital technology in the field of dynamic allocation of spectrum. It is built on

the software that provides the multi-standard, reprogrammable, multi-service for personal use. It mainly depends on the sensing of spectrum and learning ability from the surroundings in real time. Earlier the license was given to one user and it cannot be shifted to another user although in today's Wireless Network, frequency, transmission power, type of use and duration of license are the parameters that are taken into account while accessing the spectrum [1,2].

In today's world, Wireless Networks are categorized by a static spectrum assignment policy. As an outcome, some spectrum resources like 2.4 GHz unrestricted to industrial, medical and scientific band are presently available for upcoming wireless applications. Working in unlicensed band is dangerous as interference between various heterogeneous structures degrades the performance of the system [2,3]. Rapid growth in wireless communication has increased the demand of spectrum both in Licensed and Unlicensed bands. However, recent studies show that the fixed spectrum assignment policy enforced today results in poor spectrum utilization.

Cognitive Radio technology can be used to fix the spectrum scarcity problem as it allows the access of recurrent periods of the frequency bands which are

un-occupied called spectrum holes (white spaces) and thus increasing the spectral efficiency. In Wireless Network Cognitive Radio user have to recognize Primary user and hence have to sense his presence in the spectrum. This can be done by sensing the radio frequency environment and this can be done through spectrum sensing [4].

In future most of the cities will be smart cities which will consist of multiple smart building therefore it is obvious that it will not be possible to keep the control and surveillance without the presence of Wireless Sensor Networks. Wireless Sensor Network (WSN) shares spectrum with contemporary systems like Wi-Fi and Bluetooth hence faces a major challenge of bandwidth limitation [1]. There were various solutions provided for the problem of bandwidth limitation but the most promising was the Cognitive technology. Performance of existing Wireless Sensor Network can be increased by adding cognition to its behavior. The resulting Cognitive Wireless Sensor Network (CWSN) overcomes the problem of spectrum scarcity to maximum extent Spectrum sensing process is the one which differentiates the CWSN and WSN as shown in the figure 1.

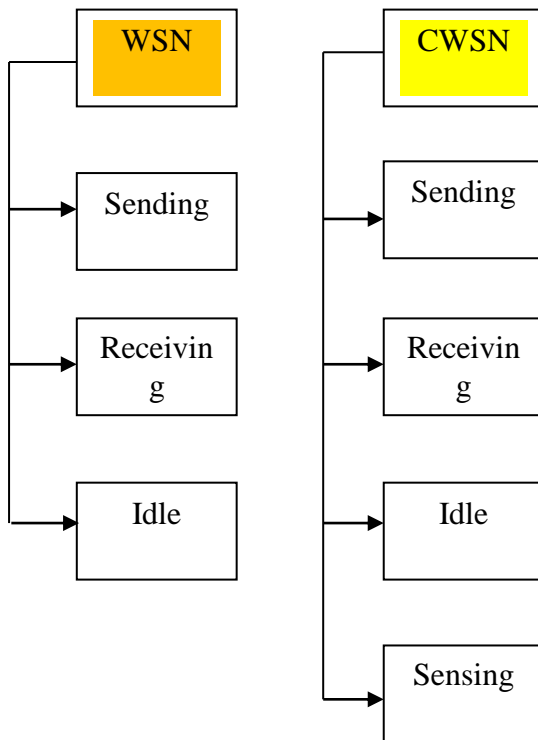

Fig. 1. Different states of WSN and CWSN [1]

The objective of this paper is to introduce readers with the Cognitive Radio technology and to emphasize on the importance of CWSN. The problem of decay in lifetime of sensor nodes during the deployment of CWSN is also been explored. Further, to counter the network lifetime problem probable solutions like

energy harvesting technique and development of energy efficient routing protocol are also been discussed hence this paper is organized as follows Section 2 discusses the issues related to network life time of Cognitive Wireless Sensor Network Section 3 discusses earlier work related to routing protocols for developing an energy efficient network. Section 4 discusses the energy harvesting possibilities finally; section 5 concludes the paper with the forwarded recommendations for future research.

2. LIFETIME OF THE COGNITIVE WIRELESS SENSOR NETWORK

Problems like bandwidth limitation are encountered whenever Wireless Sensor Network (WSN) shares spectrum with contemporary systems like Wi-Fi etc [1]. The performance of a Wireless sensor network can be improved by adding cognition in its behavior which results in Cognitive Wireless Sensor Network (CWSN). There are number of units known as sensor nodes within a Wireless Sensor Network. These sensor nodes are in general self-powered. By efficiently using the batteries in terms of energy we can increase the life time of a sensor node [2]. For the energy-efficient use of the batteries either energy efficient routing protocol can be developed or techniques like energy harvesting can be adopted which looks for the alternate source of energy which in turn increases the life time of sensor nodes. These techniques are used to harvest energy from ambient source and converts them into electrical energy [2]. And the desirable throughput subjected to energy & causality constraint can attain maximum value assuming infinite battery capacity. Hence energy harvesting Cognitive Radio is very advantageous as its lifetime is extended without the requirement of external power cables or frequent battery replacements [3].

Apart from energy efficient routing protocols and energy harvesting technique, various contention strategies were also thought of to save energy of sensor nodes [4, 5]. Among various proposals there was one which suggested development of heterogeneous Cognitive Wireless Sensor Network which was based on the combination of Cognitive Radio & energy harvesting technique [6]. Basically the idea is to reduce the energy consumption of the data sensors while maintaining the sustainability of the spectrum sensor [7]. The energy can be harvested from the surrounding environment or from the signals radiated by licensed user or from similar sources.

For increasing the life time of the sensor node theories like cluster head selection and rotation were also proposed [8]. This has initiated the need for optimal data transmission scheme between different nodes. Few schemes proposed earlier were restricted to the fact that transmission can be done across a single available spectrum at a specific time [9]. To optimize

energy efficiency under constraints for the desirable age of information, joint framing and scheduling policies were also proposed [10]. Due to collision, retransmission of data is to be done this consumes lots of energy this can be overcome by developing routing method for Cognitive Wireless Sensor Network. The method can be based on cross-layer design that jointly considers route and Spectrum selection [11]. Few protocols like Fan Access Protocol were also introduced to increase the lifetime of the [12].

3. ENERGY EFFICIENT ROUTING IN COGNITIVE WIRELESS SENSOR NETWORK

Typical sensing tasks like spectrum sensing/handoff demands extra energy from sensor nodes. As discussed earlier at present WSN is utilizing unlicensed frequency bands along with contemporary systems like Wi-Fi. It is always possible that one network may affect the performance of another network. Main operation of Cognitive sensor nodes are environmental sensing, data sending, data receiving, spectrum sensing etc. Often extra energy is consumed in spectrum sensing, idle listening, spectrum handoff, data collision and useless data transmission. Energy conservation is more crucial in CWSN as compared to the WSN [12]. Researchers are continuously working for the development of an energy efficient routing algorithm and various efforts have been made for the same. Algorithms are proposed and to explain the algorithm flow chart have been developed for an example a flow chart developed by Anuja Rawat et al is shown in figure 2.

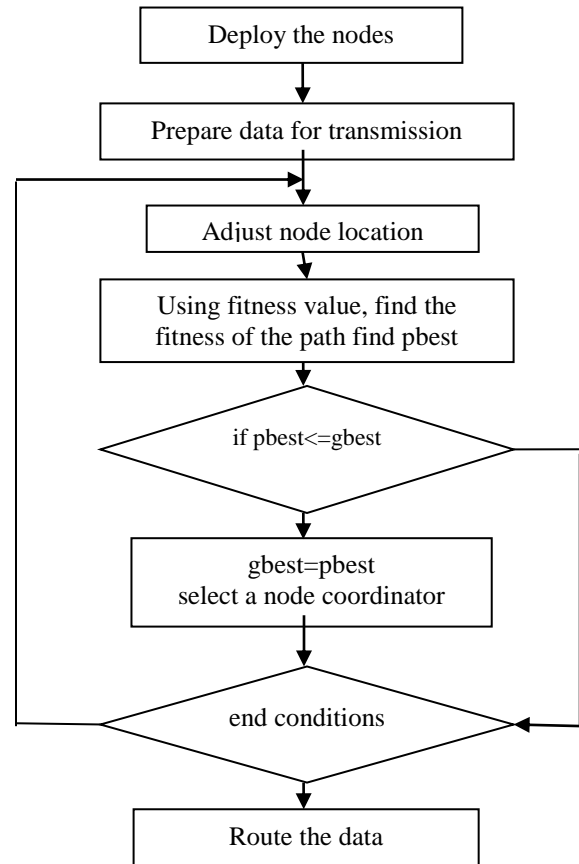

Fig. 2. Flow chart of the proposed algorithm [12]

The author in the above flow chart, procedure first initializes the nodes by initializing their position, further initializes the network and node deployment and finally get prepare for data transmission. They further defined a function known as fitness function which computes the fitness path such that the optimal value of the individual (pbest) and the optimal value of global best (gbest) can be obtained [13].

Hardware limitations, sensor network topology, production cost etc. are few factors which should be kept in mind while designing an efficient routing protocol. The design of a sensor network must be in a way so that a single node failure does not affect the working of whole network. A routing protocol using leveling, sectoring and clustering is used for increasing the network lifetime of a Wireless Sensor Network. In general, total task is segregated among different nodes such as Data discovery node, Cluster head node, Dissemination node. As each node has to perform a specific task and there is no requirement of multiple tasking hence life time of the sensor node increases. Data discovery nodes are only responsible for sensing an event. Cluster head only aggregates the data packets. Dissemination nodes simply relay the data packets. Hybrid methods are also used while proposing the algorithm [13], [14]. The results of number of events for various numbers of nodes in a

static environment for Power Aware Sectoring Based Clustering Algorithm for Wireless Sensor Networks (PASCAL) and Leveling Clustering Sectoring with Dissemination nodes (LCSD), portraying that LCSD outperforms PASCAL. Simulations have been performed to compare the behaviors of different approaches as shown below:

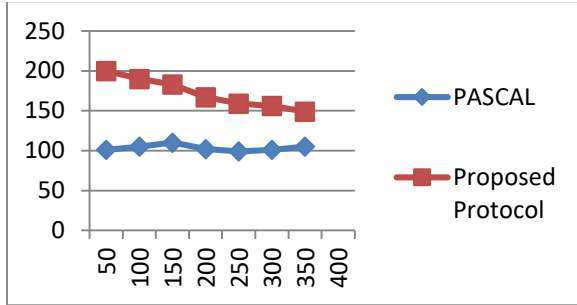

Fig. 3. Shows the comparison of proposed protocol (LCSD) and PASCAL [13]

Thus it can be said that an energy efficient routing when deployed in the network, then a huge amount of energy is saved which in turn increases the life time of the sensor nodes. The section ahead discusses harvesting of energy by sensor nodes for boosting the lifetime of the network.

4. ENERGY HARVESTING IN COGNITIVE WIRELESS SENSOR NETWORKS

A. Energy harvesting from Renewable sources

For increasing the lifetime of the network, energy harvesting techniques have been proposed by various authors. Most of the works suggested energy harvesting from renewable assets like sun, wind etc and power harvesting from radio frequency transmission. The major source of energy is sun hence paper has been published on discussing the effect of solar power harvesting on the overall performance of Wireless Sensor Networks. Hardware structure and software design along with a electricity management device have been discussed for effectively using the power harvested from the sun [14]. Distinctive sleep and wake-up techniques for sun powered Wireless Sensor Networks are also suggested. The optimization of the strategies is completed with the assistance from Markov chain queuing models [15]. In one of the paper energy harvesting from human bodies is also suggested. For harvesting energy in the form of electricity from human body's piezo electric powered impact is used. In the entire above works spectrum sharing with a primary network is not considered [16].

Few authors proposed a basic architecture of an energy harvested Cognitive Radio system. On considering a CWSN comprising of secondary transmitter, which is harvesting energy and an energy limited secondary receiver as shown in figure 4. The

secondary user whenever sees the opportunity accesses the spectrum of secondary user and to avoid any kind of collision with the primary receiver the secondary transmitter is made to execute periodically spectrum sensing and transmit data.

Diagram below E_t and E_h denote the residual energy stored in the battery at the beginning of slot t and the harvested energy in slot t , respectively

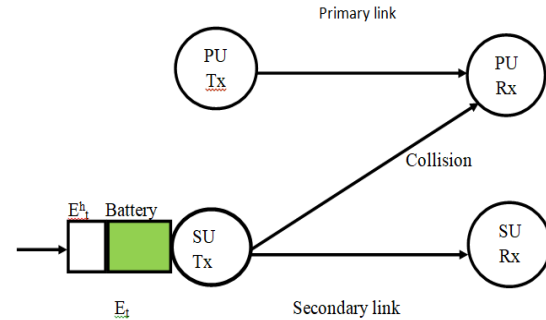

Fig. 4. Architecture of an energy-harvesting CR [6,16]

B. Radio Frequency (RF) Energy Harvesting

Apart from energy harvesting from renewable energy sources, energy harvesting can be done by using radio frequency for Wireless Sensor Network, the technical factors inclusive of the radio frequency power of harvesting and transport of the radio frequency electricity harvesting for Wireless Sensor Networks have been reviewed. Radio frequency energy harvesting is a well available solution for small sized [17]. A distributed medium access protocol, named Radio Frequency MAC, for Radio Frequency energy harvesting sensors is proposed. Antenna layout for the purpose of radio frequency harvesting also been proposed [14,18]. Rayleigh distribution is followed by the harvested voltages over the network. The overall performance of the wireless sensor networks in terms of replaces age and update cycle is investigated. But, most of the research works have not considered the spectrum sharing in their proposed work [19]. The actual performance of a power harvesting sensor node can be analyzed only when interference is encountered. In such an undesirable scenario few factors are varied in accordance with the environmental conditions. The authors have considered arbitrary distribution of sensors [19].

5. CONCLUSION

Ongoing through the different papers it is observed that spectrum scarcity problem is resolved when the existing Wireless Sensor Network is added with Cognitive properties. This leads towards the need of a Cognitive Wireless Sensor Network which is nothing but a category of Wireless Sensor Network in which a group of sensor nodes exhibit a cognitive behavior. But as less worked upon it has numerous challenges

in front of it .One of the major challenge that a Cognitive Wireless Sensor Network faces is extending the life time of the node .For example in case of collision of data packets during transmission, retransmission is to be done which results in consumption of energy. Due to remote geographical location of the nodes it is not always possible to manually change the batteries quite frequently which reduce the life time of the nodes. Developing an energy efficient routing protocol along with energy harvesting nodes is a challenging task in terms of implementation. There are numerous open research challenges for developing an energy efficient network model for Cognitive Wireless Sensor Network. The optimal scenarios for energy efficient routing and communication in Cognitive Wireless Sensor Network can also be explored.

REFERENCES

- [1] Amir Sepasi Zahmati, Sattar Hussain, Xavier Fernando “Cognitive Wireless Sensor Networks: Emerging Topics and Recent Challenges” 2009 IEEE
- [2] Antonio Sánchez, Salvador Climent, Sara Blanc, Juan Vicente Capella Hernández, Ignacio Piqueras “WSN with Energy-Harvesting: Modeling and Simulation based on a Practical Architecture using Real Radiation Levels” Miami, Florida, USA. Copyright 2011 ACM .
- [3] Sungsoo ParK., Hyungjong Kim, Daesik Hong, ” Cognitive Radio Networks with Energy Harvesting” IEEE Transactions on Wireless Communications, vol. 12(3), 2013
- [4] Mateen Ashraf, Adnan Shahid, Ju Wook Jang and Kyung-Geun Lee “Optimization of the overall success probability of the energy harvesting cognitive wireless sensor networks” Journal of Latex Class Files, vol. 14, no. 8, 2015
- [5] Yunmin Kim, Chul Wan Park “Differentiated Access Mechanism in Cognitive Radio Networks with Energy-Harvesting Nodes” Wireless Pers Commun (2016), Springer
- [6] Deyu Zhang, Zhigang Chen, Ju Ren, Student Member, Ning Zhang, Mohamad Khattar Awad, Haibo Zhou “Energy Harvesting-Aided Spectrum Sensing and Data Transmission in Heterogeneous Cognitive Radio Sensor Network” IEEE Transactions on Vehicular Technology 2016
- [7] Thanh-Duc Le, Hong-Nhu Nguyen, Si-Phu Le Dinh-Thuan ,Jaroslav Zdralek, and Miroslav Voznak “ Performance Analysis of Wireless Powered Cognitive Radio Networks Springer International Publishing AG 2018
- [8] Shohei Fujii, Osamu Takyu, Takeo Fujii, Mai Ohta “Optimal Cluster Head Selection and Rotation of Cognitive Wireless Sensor Networks for Simultaneous Data Gathering LCOIN, IEEE 2017
- [9] Haitham Abu Ghazaleh, Attahiru Sule Alfa “Optimal Scheduling in Cognitive Wireless Sensor Networks with Multiple Spectrum Access Opportunities” 2017 IEEE
- [10] Ali Valehi, Abolfazl Razi “Maximizing Energy Efficiency of Cognitive Wireless Sensor Networks with Constrained Age of Information” IEEE Transactions on Cognitive Communications and Networking 2017
- [11] Rojin Tizvar , Maghsoud Abbaspour, Mahdi Dehghani “CR-CEA: A collision- and energy-aware routing method for cognitive radio wireless sensor networks” May 2014, Springer.
- [12] Anuja Rawat, Shashi Kant Verma “Energy Efficient Protocol for Cognitive Sensor Networks Based on Particle Swarm Optimization” ICACCI, 2016 IEEE.
- [13] Ragesh Hajela, Rama Murthy Garimella, Deepti Sabnani “LCSD: Leveling Clustering and Sectoring with Dissemination Nodes to Perform Energy Efficient Routing in Mobile Cognitive Wireless Sensor Networks “International Conference on Computational Intelligence and Communication Networks 2010 IEEE
- [14] Z. Ding, S. M. Perlaza, I. Esnaola and H. V. Poor, "Power Allocation Strategies in Energy Harvesting Wireless Cooperative Networks," IEEE Trans. Wireless Communication, vol. 13, no. 2, pp. 846-860, February 2014.
- [15] I. Krikidis, "Relay Selection in Wireless Powered Cooperative Networks with Energy Storage," IEEE J. Sel. Ares Commun., vol. 33, no. 12, pp. 2596-2610, Dec. 2015.
- [16] A. A. Nasir, X. Zhou, S. Durrani and R. A. Kennedy, "Relaying Protocols for Wireless Energy Harvesting and Information Processing," IEEE Trans. Wireless Communication, vol. 12, no. 7, pp. 3622-3636, July 2013.
- [17] P. N. SON, H. Y. KONG, "Exact outage analysis of energy harvesting underlay cooperative cognitive networks," IEICE Trans. Commun., 4, 661-672, 2015.
- [18] Y. Liu, S. A. Mousavifar, Y. Deng, C. Leung and M. ElKashlan, "Wireless Energy Harvesting in a Cognitive Relay Network," IEEE Trans. Wireless Communication, vol. 15, no. 4, pp. 2498-2508, April 2016.
- [19] C. Zhai, J. Liu and L. Zheng, "Cooperative Spectrum Sharing With Wireless Energy Harvesting in Cognitive Radio Networks," IEEE Trans. Veh. Tech., vol. 65, no. 7, pp. 5303-5316, July 2016.