

# THE INTERNATIONAL JOURNAL OF BUSINESS & MANAGEMENT

## The Influence of Safety Training on the Practices of Occupational Health and Safety in Small Scale Mining Firms

**Dominic Nkolimwa**

Assistant Lecturer, Institute of Social Work, DSM, Tanzania

**Dev Jani**

Associate Professor, University of Dar es Salaam Business School, DSM, Tanzania

**Theresia Dominic**

Lecturer, University of Dar es Salaam Business School, DSM, Tanzania

### **Abstract:**

*This article is aimed at analyzing the influence of Safety Training (ST) on the practices of occupational health and safety in small scale mining firms. It presents an insight that promotes security, hardworking and comfort of employees after been secured. This in return, has positive impact to the national development. This article examines on how safety training can influence the practices of occupational health and safety at workplace. The Structural Equation Modeling (SEM) has been used to analyse the data collected from 297 small scale mining firms, test models and test all hypotheses on direct effect of safety training on the implementation of occupational health and safety. The results demonstrate that safety training (ST) has positive influence on the implementation of Organization Safety Support (OSS) and Proactive Hazard Control (PHC). These results imply that safety training should be enhanced in order to improve the implementation of health and safety at workplace.*

**Keywords:** Occupational health and safety, management practices, safety Training

### **1. Introduction**

The implementation of occupational health and safety (OHS) is mandatory in many nations due to its vital role of promoting security, hardworking and comfort to employees (Yusuf et al, 2012). It also acts as a catalyst to the economic, social and political sectors development. However, its practices is still questionable to many working organizations especially in developing nations due to inadequate employee's safety training which results into accidents, illness and death of employees at workplace.

It is estimated that more than 2.3million of fatalities are occurring every year all over the world, following the poor implementation of (OHS) which causes a loose of about 6300 employees in a day (ILO, 2014). Katsuro et al (2010) stated that organisations that ignore health and safety, regularly impacts their productivity due to employees' absenteeism, loss of goodwill from the community. For instance, Michelo (2009) states that at least 165 injuries and 20 fatalities were reported at Zambia copper mining. Small scale mining employees' are at in the risk, especially in developing countries like Tanzania. Related matters and deaths are reported probably caused by poor inadequate of safety training to the employees which are part of management functions (Khdair and Wameedh, 2011). Small scale mining is reported to be among of the most risk and dangerous occupation in Tanzania due to a number of limitations including poor safety training to the employees which cause severe accidents that count for lives of individuals at workplace (Abdulla et al, 2009).

The way workers are protected and compensated, following injuries and other ailments associated with exposing the workforce to hazardous substances, is a major public concern that needs collective responsibility to stimulate all stakeholders to take acceptable measures and feel responsible to their workers. For example, in 2006, a miner was killed by falling loose rocks and in March 2007, the death of three miners in Same district was attributed to collapsed pits, Mererani, in 2008, at least 65 miners drowned to death after floods swept through underground pits and tunnels (Maginga et al, 2013).

Literatures on OSHA suggest that in order to protect employees from occupational accident and create safety culture, safety training is important and need to be put in place to prevent accidents and injuries in the organisation (Vredenburg, 2002; Ali et al, 2009). The practice of safety training on OHS is contingent to priority since it depends on the managerial commitment to the matter. However, safety is significant to all human being, Laursen and Foss (2013); Tan & Nasuridin (2011) Khdair and Wameedh (2013) and Demo et al (2012) conducted studies on OHS and identified leadership style, employees' attitude and hiring practices as important elements of management practices for safety culture. While other researchers like Desa et al (2013) listed rewards, employee's involvement, employee's communication and management commitment as important elements towards improving working condition of employees.

Basing on the discussion of various studies on OHS it showed that there are different views among researchers on the factors influencing health and safety in the organization. Therefore, this article used Safety training as an important factor which influences OHS to the employees, an argument which has been supported by (Khair & Wameedh, 2013; Nursyazwani & Zamri 2013; Gupta and Upadhyay, 2012).

There are some efforts done by Tanzania government in view of this shortcoming as measures to protect its employees by establishing the Occupational Safety and Health Authority (OSHA) in 1997, endorsement of Occupational Health and Safety (OHS) Act No. 5 of 2003, establishment of Occupation Health and Safety Policy of 2009, Compensation Act No 20 of 2008, the ratification of ILO Convention No. 170 of 1993 in 2014 about safety in the use of chemical at work and Mineral Policy of 2009, which enhance the best practices of health and safety as among of the initiative of solving the occupational hazards.

Despite the above measures, the mining industry in Tanzania is still associated with fatal injuries, accidents and deaths at workplace. Most of those accidents are associated with rock fall, fire explosions, automobile equipment accidents, falls from higher heights, entrapment, but also flooding of underground workings and suffocation (Museru and Munthali, 2013). For example, in 2017, about 14 miners were trapped for four days (URT, 2017), while in 2015 at least 20 miners died and other six were trapped underground for 41 days before been rescued at Bulyanhulu Gold mines (URT, 2017; Reuters, 2015).

However, the managers in charge of H&S activities have not been able to reduce occurrences of accidents especially in small scale mining firms (Surienty, 2012; Mills & Lin, 2001). This was due to the persistent of occupational injuries, death, illness and accidents (Samage, 2014). So seriousness on provision of safety training commitment to the managers responsible for employee's safety issues is questionable. There is lack of understanding on the role of safety training as an internal factor and effective OHS in Tanzanian. Therefore, there is a need to consider the influence of safety training on the implementation of OHS in small scale mining firms. Based on aforementioned issues literature did not consider the relationship between safety training and the implementation of Occupational health and safety in small scale mining firms. As a result this article analyzed the influence of safety training on the practices of OHS in Tanzania's small scale mining firms.

## 2. Literature Review

This article used ERG theory proposed by Alderfer (1969) expanding the Maslow's basic needs by refined five stages into three which are existence needs, relatedness needs and growth needs. This theory has become popular and predominant in explaining different concepts on organisational management with new methods of considering human behaviour and attitude (Yang and Chen, 2011). It explains the significances on safety to the employees at workplaces regardless their political, economic and social status, so it tells more about maintaining the safety to all employees. It has been used to explain and contribute to the human behavior which direct connects to the health and safety at workplace. Therefore, this theory is significant to this article because it explains safety issues to the organisation. Basically, the theory insists the safety to all employees regardless their status (Caulton, 2012). Generally in ERG the existence needs explains about safety as among of basic needs to a human whereby consider the prevention from fear, anxiety, threat, danger and tension at working environment that is free from threats or harm to all employees in the organisation. With all this facts, ERG can play an important role theoretically in explaining the influence of management practices on the implementation of occupational health and safety at workplace. Therefore this theory is relevant article since it explains the safety behaviour to the employees in the organization.

Asghar and Saeed (2012) state that training is about requiring the skills, abilities and knowledge that is necessary in performing specific tasks in the organization. Kaynak et al (2016) training stimulates the proper utilization of the machines and other equipment in the organization. So training should be design to offer employees with the skills, attitudes and knowledge required for solving certain purpose in the organization. Therefore the organization should keep employees with necessary required health and safety skills, knowledge and abilities to manage disasters at workplace (Dabale, et al, 2014). That argument is conflicting with Mupararano, Katsuro, Gadziravi and Taruwona (2010) urging that training employees does not help the reduction of accidents since the training provided is basing on the status of employees, since employees with short-term contracts are ignored in safety training comparing to the permanent employees. Hence, the following hypotheses were developed:-

- H<sub>1</sub>: The safety training has positive influences on the implementation of organisation safety support programmes at workplace.

Toklu, Elci, Toklu and Kaynak (2016) stated that workers perception and safety climate as the factors enhancing the practices of occupational health and safety at workplace, so the literature, enhance the management to concentrate with employees mind set insure the employee's safety perception. While Mashia et al (2016) state that employee's behaviour becomes more reliable, trust on the collective workforce is also enhanced which, in turn, can lead to increased cooperation and information sharing. Safety training directly increases the safety-related knowledge corresponding to the occupational risks posed to workers in job tasks. Therefore the following hypotheses were developed:-

- H<sub>2</sub>: The safety training has positive influences on the implementation of proactive hazard control programmes at workplace.

### 2.1. Conceptual Framework

The conceptual framework has been developed in order to show the relationship between independent and dependent variables. The independent variables have been featured by Safety Training (ST) while dependent variables

have featured by Organization safety support (OSS) to reduce hazards and Proactive hazard control (PHC) to maintain safety at workplace.

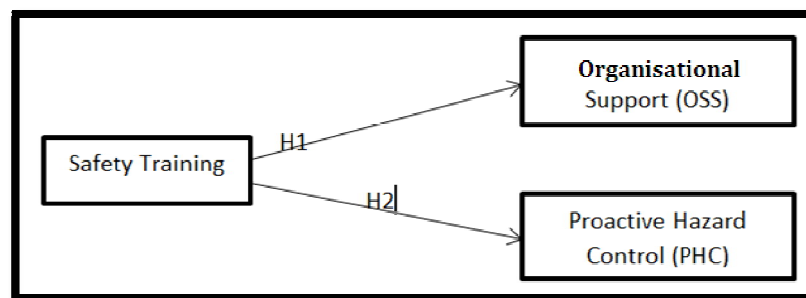

Figure 1: Conceptual Framework  
Source: Synthesized from the literature, 2018

## 2.2. Research Methodology

This study applied explanatory research design whereby information from respondents been collected through quantitative method of the study which provided the statistical generalization of findings (Mashia et al, 2016). This research design has been selected because it enables the researcher to have greater control over accuracy of findings. Data were collected from three regions (3) namely Shinyanga, Arusha and Geita. These regions have been selected because are the dominant regions dealing with mining activities in Tanzania. Also these areas have several reported to experience high rates of accidents associated with mining (Samage, 2014). About 297 questionnaires were used to collect the quantitative data meanwhile structural equation model SEM and percentage was used.

## 2.3. Measurement of Implementation of Occupational Health and Safety

The established instrument to measure the implementation of Occupational Health and Safety (OHS) in this study was the Organisation Safety Support (OSS) and Proactive Hazard Control (PHC). Safety rules and procedures, plus the uses of first-Aid support are uses in the measurement of OSS and PHC (Kaynak et al (2016). Various literatures used the same measurement to measure the accuracy of implementation of health and safety at workplace, since the provision of OSS and PHC is the indicator for health and safety implementation in the organization Villanueva and Nunez, 2010). Safety training programs should adhering instruction of management about health and safety at workplace. The verification of safety work practices controlling the work related injuries, availability of hazard warning signal and provision of feedback to employees about unsafe behaviour is very important to the management (Khdair and Subramaniam, 2011).

## 3. Results of the Study

### 3.1. Organization Characteristics

The study was conducted in small scale mining firms operating from Shinyanga, Arusha and Geita regions; whereby about 297 (94%) firms were involved in this study. The main activities of mining involves extracting and selling minerals, however small scale miners are not benefiting and are not educated. The activities of these firms are operated in risks and dangerous workplaces and its practices seem to be driven by poverty and social problem.

### 3.2. Safety Training on Occupational Health and Safety in Small Scale Mining Firms

This study had four assumptions which were tested in order to justify the use of SEM. These assumptions tested were the normal distribution of the data, homoscedasticity and identification of outliers. Using the P-P Plot of regression, standardized residuals data in all research variables were normally distributed. While in addition, no multicollinearity problem was found since the Tolerance Value (TV) and Value Inflated Factor (VIF) in all variables used in this research were greater than 0.1 for TV and less than 10 for VIF respectively as recommended by Williams (2015). The process of data screening also revealed that, there were no problem of heteroscedasticity since the scatter plot showed that the residuals were evenly distributed around the axis. In the case of outlier, the outlier labeling methods were used and about three outliers were omitted after being found in this study.

### 3.2. The Direct Relationship between Safety Training on the Implementation of Occupational Health and Safety in Small Scale Mining Firms

In this section, there were two hypotheses, namely H<sub>1</sub> and H<sub>2</sub>. H<sub>1</sub> state that ST has positive influence on the implementation of OSS programmes at workplace and H<sub>2</sub> stated that ST has positive influence on the implementation of PHC programmes at workplace.

The path analysis results showed that there was significant relationship between ST programs and implementation of OSS at workplace ( $\beta = 0.465$ , Significant at 0.001). Also the path analysis showed that there was significant relationship between ST and implementation of PHC at workplace ( $\beta = 0.394$ , Significant at 0.001). Hence, each hypothesis that is H<sub>1</sub> and H<sub>2</sub> were supported. Table 1: Provides the regression weights and the significance level:-

Path			Estimate	S.E.	C.R.	P	Label
OOSS	<---	SST	.597	.092	6.458	***	
PPHC	<---	SST	.555	.096	5.759	***	

Table 1: The Regression Weights for the Direct Relationship

Source: Field Data (2018)

\*\*\* Means, it is significant at 0.001

The developed model shows of the direct relationship between safety training and the implementation occupational health and safety at workplace. In this analysis, the model demonstrates influence of ST in identifying safety issues on the implementation of OSS and PHC at workplace. Also, the model shows the relationship between ST programs on OSS and PHC. Figure 2 presents the model on the direct relationship between safety training and the implementation of occupational health and safety at workplace.

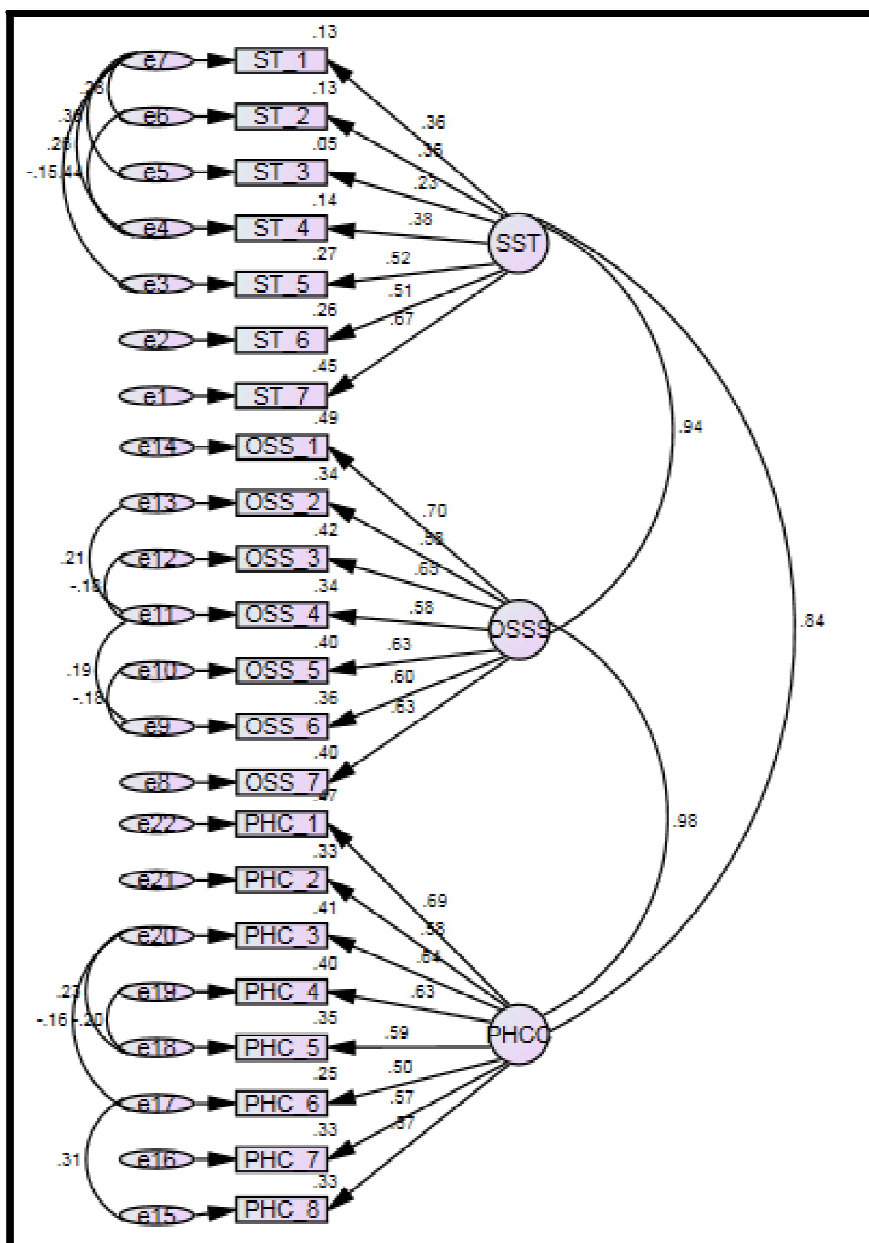

Figure 2: The Developed Structural Equation Model for the Direct Relationship.

Source: Field Data (2018)

The model shows that the additional unit of the standard deviation of ST programs led to the 0.45 significant increases in standard deviation of the implementation of OSS at workplace. Again, it shows that the additional unit in standard deviation of ST programs led to the 0.39 significant decreases in PHC at workplace. This means that, management practices namely ST implementation at workplace had different contribution on OSS and PHC at workplace.

The model was assessed to see whether it fits the data well by examining the model fit indices. The model fit indices included CMIN/df, GFI, AGFI, CFI and RMSEA. The indices indicated that the model fits well the data because they were all within the recommended values. The Chi-square value was 143.171, P-value of 0.000 while the degree of freedom

was 33. The Chi-square value was insignificant which indicated that there was no statistically significant difference between the default model and saturated model. Table 2 presents the model fit indices with the recommended value.

Goodness of Fit Measure	Calculated Index *	Recommended value	Author
CMIN/df	1.934	<5	Bollen (1989); Ullman (1996)
GFI	0.903	$\geq 0.90$	Byrne (2010)
AGFI	0.873	$\geq 0.80$	Chau and Hu (2001)
CFI	0.918	$\geq 0.90$	Hair et al. (2010)
RMSEA	0.056	< 0.08	Hoe (2008); Steiger (2007) cited by Hooper, Coughlan & Mullen (2008)

Table 2: Goodness of Fit Indices for the Direct Model  
Source: Field Data (2018)

#### 4. Discussion of Findings

The findings revealed that safety training programs has positive influence on implementation of organization safety support at workplace. Therefore if management invest on provision of safety training to the employees' the accidents, injuries cases would be minimized. Asghar and Saeed (2012) argument support the findings that safety training has a great impact towards minimizing and controlling the accidents at workplace, because when employees are training they become aware on how to avoid unnecessary risks at workplace. In other hand the results shown that safety training has positive influence for the implementation of proactive hazard control at workplace. Any organization which value its human resources tends to maintain health and safety by preparing the health and safety proactive hazard control strategies so that to protect employees at workplace. This also has been supported by Mashia et al (2016) stated that safety training is an important risk prevention and control strategies to guarantee every employee in a good workplace conditions.

Keffane (2014) urged that safety training is a key factor in maintaining and changing workers attitude towards safety. Providing instruction about hazard recognition and control measures and learning safe work practices protective equipment, and acquiring knowledge of emergency procedures and preventive actions maintain safety at workplace, (Yorio and Wachter, 2014). Though some literatures like Toklu, Elci, Toklu and Kaynak (2016) argued that safety training has no impact to the control of accidents because it been provided depending on the status of employees in the organization, but safety training if has been designed well has positive impact towards reducing accidents at workplaces (Khdair andSubramaniam, 2011).

#### 5. Conclusion

The article investigated the influence of safety training on the implementation of health and safety in small scale mining. Literatures informed that safety training has contribution to the process of minimizing accidents at workplace (Mashia et al 2016). The argument been supported by Keffane (2014) who stated that safety training has an impact towards maintain safety of employees at workplace. Therefore this article concluded that ST programs significantly influence the implementation of OSS and PHC at workplace. So the organization to realize safety of employees well designed training should prepare and impacted to all employees.

#### 6. Recommendations

The results revealed that Safety training programs significantly influence the proper implementation of health and safety at workplace. With thus facts, if all organizations (private and public) should put an emphasizes on safety training in health and safety matters, accidents, risks injuries and deaths at workplace will be reduced in high rate and production will be improved. So managers should put emphases on health and safety issues in their organizations, if really they want to improve their efficiency. Also government officials should make sure that all organisations prepare and provide safety training to all employees so that enhance the provision of health and safety compliance. If safety training is been provided it maintain the organisational health and safety culture to the management and employees at large and a results minimize risks at workplace.

#### 7. Limitation of the study

Safety training may not have the same influence in all working industries hence the study concentrated only in small scale mining firms. Tanzania has various working industries which involves people. This this study did not consider the influence of safety training on other working industries and these findings do not dispute to all working industries in Tanzania.

#### 8. Areas of Further Study

Another study may focus on the influence of safety on occupational health and safety in small scale mining. The study may examine whether the influence of safety training differ to other working industries, namely as process industries, banking, agriculture, education industries.

## 9. References

- i. Abdullah, N, Spickett, J and Rumchev, K (2009) "Assessing Employees Perception on Health and Safety Management in Public Hospitals". *International Review of Business Research Papers* 5(4), 54-72.
- ii. Akpan, E (2011) "Effective Safety and Health Management Policy for Improved performance of organization in Africa". *International Journal of Business and Management* 6(3),1833-8119.
- iii. Alderfer, C (1989) "Theories Reflecting my Personal Experience and Life dent". *The Journal of Applied Behavioral Science*, 25(4), 351-365.
- iv. Asghar, M and Saeed, M (2012) "Examining the Relationship between Training, Motivation and Employees Job Performance – The Moderating Role of Person Job Fit". *Journal of Basic and Applied Scientific Research*, 2(12), 12177-12183.
- v. Babatunde, O and Ayodele, L (2013) "Practice of Occupational Safety among artisanal Miners in a Rural Community in Southwest Nigeria". *International Journal of Science, Environment and technology*, 2 (4), 622-633.
- vi. Byrne, B.M (2010) "Structural Equation Modeling with AMOS: Basic Concepts, Application and Programming". Routledge, New York.
- vii. Caulton, J (2012) "The Development and Use of the Theory of ERG: A Literature Review, Emerging," *Leadership Journeys*, 5 (1), 2-8.
- viii. Chau, P.Y.K and Hu, P.J.H (2001) "Information Technology Acceptance by Individual Professional: A Model Comparison Approach". *Decision Sciences*, 32 (4), 699-719.
- ix. Dabale, W, Jagero and Nyauchi, M (2014) "The Relationship between Training and Employee Performance: The Case of Mutare City Council, Zimbabwe". *International Journal of Human Resource Studies*, 4(4), 2162-3058.
- x. Demo, G, Neiva, I and Rozzett, K (2012) "Human Resource Management Policies and Practices Scale (HRMPPS): Exploratory and Confirmatory Factor Analysis". *BAR, Rio de Janeiro*, 9(4): 395-420.
- xi. Desa, A, Habidin, N, Hibaullah, S, Fuzi, N & Zamri, F (2013) "Occupational Safety and Health Administration (OSHA) Practices and OSHA Performance in Malaysian Automotive Industry". *Journal of Studies in Social Sciences*, 4(1), 1-15.
- xii. Drumm, H (1999) "Transaction Costs in Human Resource Management Interaction and Interdependence with Organisational Structure". *Employee Relations*, 21 (5), 463-484.
- xiii. Dwomoh, G, Owusu, E and Addo, M (2013) "Impact of Occupational Health and safety Policies on Employees' Performance in the Ghana's Timber Industry", *International Journal of Education and Research*, 1 (12), 2201-6740.
- xiv. Elgstrand, K and Vingård, E (2013) "Occupational Safety and Health in Mining, Work and Health, University of Gothenburg, Kompndiet, Gothenburg". *International Journal of Scientific research*, 5 (1), 2277-8179.
- xv. Hair, J.F, Black, W.C, Babin, B.J and Anderson, R.E (2010) *Multivariate Data Analysis*, 7<sup>th</sup> Edition. Upper Saddle River, New Jersey. Prentices Hall.
- xvi. Hoe, S.L (2008) "Issues and Procedure in Adopting Structural Equation Modeling Technique". *Journal of Applied Quantitative Methods*, 3 (1), 76-83.
- xvii. ILO, (2014), *Creating Safe and Healthy Workplaces for All Report for the G20 Labour and Employment Ministerial Meeting*. Melbourne, Australia, 10-11 September 2014.
- xviii. Irawanto, D (2015) "Employee Participation in Decision-Making, Management". *The International Journal of Business and Management*, 1(20), 105-127.
- xix. Katsuro, P, Taruwona, M and Mupararano, S (2010) "Impact of Occupational Health and Safety on Worker Productivity: A case of Zimbabwe Food industry". *African Journal of Business Management*, 4(13), 2644-2651.
- xx. Kaynak, R and Toklu, A (2016) "Effects of Occupational Health and Safety Practices on Organizational Commitment, Work Alienation, and Job". *International Journal of Business and Management*, 11 (5), 1833-8119
- xxi. Kaynak, R and Toklu, A (2016) "Effects of Occupational Health and Safety Practices on Organizational Commitment, Work Alienation, and Job". *International Journal of Business and Management*, 11 (5), 1833-8119
- xxii. Keffane, S (2014) "Communication's Role in Safety Management and Performance for the Road Safety Practices". *International Journal of Transportation Science and Technology*, 3(1), 79-94.
- xxiii. Keffane, S and Delhomme, P (2013) *Assessing the Mediating Role of Communication in Safety Management and Performance for Road Safety Practices: French Organizations Model*. *Proceedings Book*, 26.
- xxiv. Khairul, M (2017) "An Occupational Safety and Health Management System Related to Level of Safety Culture in Construction Site". *Journal of Advanced Research in Business and Management Studies*, 8 (2), 19-21.
- xxv. Khattak, M, Bashir, F and Urooj, S (2012) *Employee Involvement and Participation at Work: A Case Study of OTCL After Privatization*. *International Journal of Academic Research in Business and Social Sciences*, 2 (6), 2222-6990.
- xxvi. Khdair, W, Shamsudin, F and Subramaniam, C (2011) *A Proposed Relationship between Management Practices and Safety Performance in the Oil and Gas Industry in Iraq*. *World Review of Business Research*, 1(3), 27-45.
- xxvii. Laursen, K and Foss, N (2013) *Human Resource Management Practices and Innovation*, Oxford University Press.
- xxviii. Lawrence, R and Lorsch, W (1967) *Organization and Environment: Managing Differentiation and Integration*. Boston, MA: Harvard Business School Press.
- xxix. Loeppke, R (2008) *The Value of Health and the Power of Prevention*, International Emerald Group Publishing Limited, 1 (2), 95-108.
- xxx. Lunenburg, F and Irby, B (2013) *Development of Administrative Thought: A Historical Overview*. *International Journal of Organizational Theory and Development* 1(1).

- xxxi. Maginga, E, Purefoy, J (2013) Human Rights Watch Toxic Toil, Child Labor and Mercury Exposure in Tanzania's Small-Scale Gold Mines, 978 (1), 62313-0381.
- xxxii. Marsh, W, Davies, R and Phillips (1998) "The Role of Management Commitment in Determining the Success of a Behavioural Safety Intervention". *Journal of the Institution of Occupational Safety & Health*, 2(2), 45-56.
- xxxiii. Mashi, M(2014) "Moderating Effect of Consideration of Future Safety Consequences on the Relationship between Safety Management Practices and Safety Performance among Health care Workers: A Conceptual Analysis". *International Journal of Academic Research in Business and Social Sciences*, 4 (6), 2222-6990.
- xxxiv. Mashia, M., Subramaniama, Cand Joharia, J (2016) "The Effect of Safety Training and Workers Involvement on Healthcare Workers Safety Behavior: The Moderating Role of Consideration of Future Safety Consequences". *International Journal of Business Management (IJBM)*, 1 (2).
- xxxv. Mensah, Jand Tawiah, K (2016) Occupational Health and Safety and Organizational Commitment: Evidence from the Ghanaian Mining Industry. *Elsevier Journal*, 7 (3), 225-230.
- xxxvi. Merttens, D.M (2003) Mixed Methods and The political of Human Research: the Transformative –Emancipatory Perspective. In A. Tashakkori& C. Teddlie (Eds) *Handbook of Mixed Methods in Social and Behavioural Research*, Thousand Oaks Sage Publications, pp 135-64.
- xxxvii. Micah, M andAjay, S (2014)" Techniques &Determination of sample size in Applied Statistics Research: AnOverview". *International Journal of Economics, Commerce and Management United Kingdom* 11(11),3-14.
- xxxviii. Michelo, P, Bratveit, M and Moen, B (2009) Occupational Injuries and Fatalities in Copper Mining in Zambia. *Occup med* 59 (3), 191-4.
- xxxix. Mills, Aand Lin, J (2001) Measuring the Occupational Health and safety Performance of Construction Companies in Australia. *MCB University Press*, 19(3),131-139.
- xl. Mukhrejji, Pand Albon, D (2010) *Research Methods in Early Childhood: An Introductory Guide*, Sage, London, 88.
- xli. Mupararano, S, Katsuro, Pand Gadzirayi, (2010) "Impact of Occupational Health and Safety on Worker Productivity: A case of Zimbabwe Food Industry". *African Journal of Business Management* 4(13), 2644-2651
- xlii. Museru, L, Boniface, R, Munthali, Vand Lett, R(2013). "Occupational Injuries and Fatalities in a Tanzanite Mine". *The Pan African Medical Journal*.
- xliii. Nunnally, C (1994) *Psychometric Theory* (3rd ed.). New York: McGraw -Hill.
- xliv. Nursyazwani, Mand Zamri, M(2013)"Occupational Safety and Health Administration (OSHA) Practices and OSHA Performance in Malaysian Automotive Industry". *Journal of Studies in Social Sciences*, 4 (1),1-15.
- xlv. Nordlof H, Westerling, R, Hogberg, H and Wiitavaara, B(2017) "A cross-Sectional study of Factors Influencing Occupational health and Safety Management Practices in Companies", *Journal homepage: www.elsevier.com/locate/ssci*.
- xlvi. Oakman, J and Bartram, T (2017) "Occupational Health and Safety Management Practices and Musculoskeletal Disorders in Aged care Are Policy, Practice and Research Evidence Aligned". *Journal of Health Organization and Management*, 31 (3), 331-346.
- xlvii. Ozguner, Z and Mert, O (2014) "A Managerial Point of View on the Relationship Between of Maslow's Hierarchy of Needs and Herzberg's Dual Factor Theory", *International Journal of Business and Social Science* 5(7),1-7.
- xlviii. Rzepecki, J (2012) "Cost and Benefits of Implementing an Occupational Safety and Health Management System (OSH MS) in Enterprises in Poland". *International Journal of Occupational Safety and Ergonomics*, 18(2), 181-193.
- xlix. Samage, B (2014) *The United Republic of Tanzania Ministry of Energy and Minerals Management of Safety, Health and Environment Issues in the Mines*.
- I. Sofijanora, Vand Chatleska, Z (2013) "Employee's Involvement and Organization Performance; Evidence from the Manufacturing Sector in Public of Macedonia, Trakia" *Journal of Sciences* 11 (1), 31-36.
- ii. Surity, L (2012) *Management Practices and Occupational Health and safety Implementation in SMES in Malaysia*.
- iii. Sembe, Fand Ayuo, A (2017) "Effect of Selected Occupational Health and Safety Management Practices on Job Satisfaction of Employees in University Campuses in Nakuru Town, Kenya". *Journal of Human Resource Management*, 5(5),3768-3773.
- iiii. Steiger, J. H (2007) Understanding the Limitations of Global fit Assessment in Structural Equation Modeling. *Personality and Individual Differences*, 42 (5), 893-98.
- liv. Tan, C and Nasurdin, A (2011) "Human Resource Management Practices and Organizational Innovation: Assessing the Mediating Role of Knowledge Management Effectiveness", *Electronic Journal of Knowledge Management* 9 (2), 155-167.
- lv. Tawiah, K (2011)"Occupational Health and Safety. Key Issues and Concerns in Ghana" *International Journal of Business and Social Science*, 3(9),2-14.
- lvi. Toklu, I, Elcil, M, Arzu, Tand Kaynakl, R (2016) Effects of Occupational Health and Safety Practices on Organizational Commitment, Work Alienation, and Job Performance: Using the PLS-SEM Approach. *International Journal of Business and Management*; 11(5), 1833-8119.
- lvii. United Republic of Tanzania - URT (2015) *Trend on Occupational Accidents at Work Place*. Ministry of State in the Prime Minister's Office responsible for Policy, Parliamentary Affairs, Labour, Employment, Youth and the Disabled.
- lviii. United Republic of Tanzania – URT (2017) *14 Miners Trapped Underground for 4 days at Geita*. Ministry Home affairs.

- lix. United Republic of Tanzania- (URT) (2017) Occupational Health and Safety (OHS) Act No. 5 of 2003. Ministry of State in the Prime Minister's Office responsible for Policy, Parliamentary Affairs, Labour, Employment, Youth and the Disabled
- lx. Villanueva, M and Nunuz, I (2010) "Professional practice Safety Capital: The Management of Organizational Knowledge on Occupational Health and Safety". *Journal of Workplace Learning*, 23 (1),56-71.
- lxi. Vredenburg, A (2002) "Organizational safety: Which management Practices are Most Effective in Reducing Employee Injury Rates". *Journal of Safety Research*, 33(2002), 259 – 276
- lxii. Yang, C and Chen, C (2011) "An Empirical Study of the Existence, Relatedness, and Growth (ERG) Theory in Consumer's Selection of Mobile value –Added Services". *African Journal business Management*, 5 (19), 7885-7898.
- lxiii. Yorio, P and Wachter, J (2014) "Safety-and-Health-Specific High-Performance Work Practices & Occupational Injury and Illness Prevention: The Mediating Role of Task & Team Safety Proficiency Behaviors". *Journal of Safety, Health & Environmental Research*, 10 (1),1368-2168.
- lxiv. Yusuf, R, Eliyana, A and Sari, O (2012) "The Influence of Occupational Safety and Health on Performance with Job Satisfaction as Intervening Variables". *American Journal of Economics*, Issue: 136-140.